

Matthias Kühle-Weidemeier (ed.)

# **EU Waste Management 2010**

**European waste management in the view of the  
waste framework directive**

**Proceedings**

**Cologne, 8<sup>th</sup> – 9<sup>th</sup> of June 2010**

Organiser

**wasteconsult**  
INTERNATIONAL

Gold Sponsor



**Cuvillier Verlag**

Matthias Kühle-Weidemeier (ed.)

# **EU Waste Management 2010**

European waste management in the view of the  
waste framework directive

**Proceedings**

**Cologne, 8<sup>th</sup> – 9<sup>th</sup> of June 2010**

Organiser

**wasteconsult**  
INTERNATIONAL

Gold Sponsor



**Cuvillier Verlag**

## **Bibliografische Information der Deutschen Nationalbibliothek**

Die Deutsche Nationalbibliothek verzeichnet diese Publikation in der Deutschen Nationalbibliografie; detaillierte bibliografische Daten sind im Internet über <http://dnb.d-nb.de> abrufbar.

1. Aufl. - Göttingen : Cuvillier, 2010

978-3-86955-344-3

© CUVILLIER VERLAG, Göttingen 2010

Nonnenstieg 8, 37075 Göttingen

Telefon: 0551-54724-0

Telefax: 0551-54724-21

[www.cuvillier.de](http://www.cuvillier.de)

Alle Rechte vorbehalten. Ohne ausdrückliche Genehmigung des Verlages ist es nicht gestattet, das Buch oder Teile daraus auf fotomechanischem Weg (Fotokopie, Mikrokopie) zu vervielfältigen.

1. Auflage, 2010

Gedruckt auf säurefreiem Papier

978-3-86955-344-3

Consulting - Engineering - Project Management - Research

**ECOENERGY**

Gesellschaft für Energie- und Umwelttechnik mbH  
 Bei dem Gerichte 9  
 D-37445 Walkenried  
 info@EcoEnergy.de  
 www.EcoEnergy.de

Fon: +41.52.51110.10  
 Fax: +41.52.51110.19  
 Contact person:  
 Dipl.-Ing. Reinhard Schu



Thermal Treatment of Waste / Power Plants

**BiFuelCycle**®

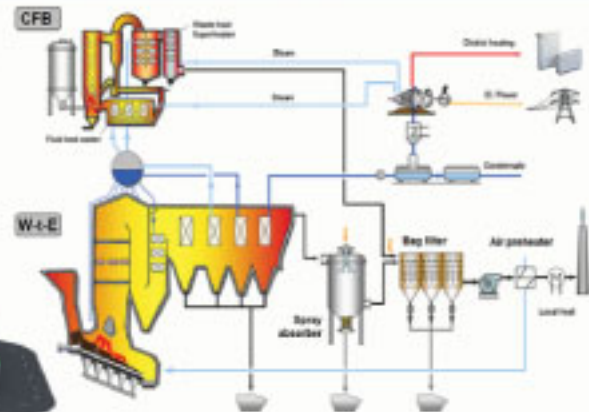

Low Temperature Drying for Waste Recycling

**TUNNEL DRYER**

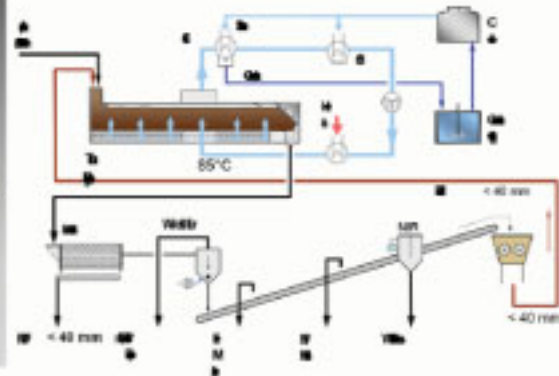
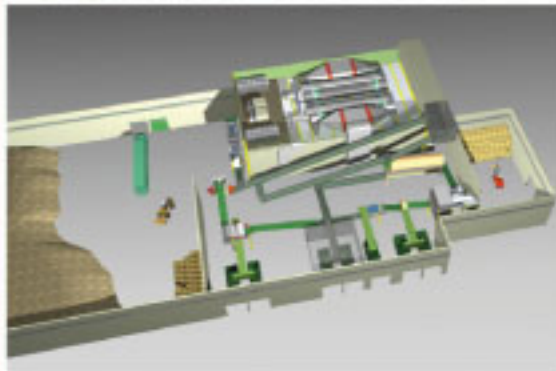

Mechanical Biological Treatment of Waste

**SCHUBIO**®



kba  
hard

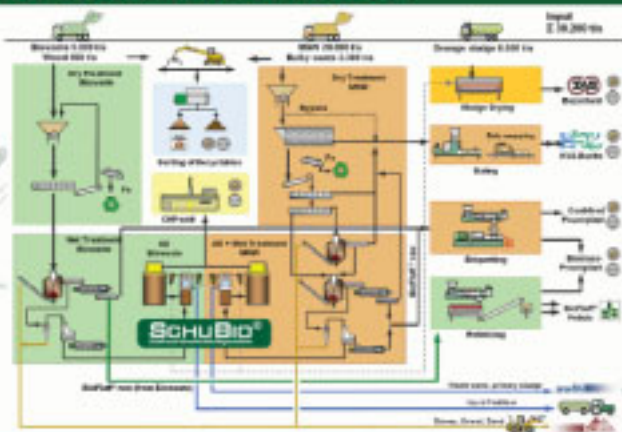





### Conferences

Days of waste research (German)  
Landfill practice conference (German)  
International Symposium MBT



### Photovoltaics

Feasibility studies  
Design engineering  
BOT models



### Mechanical biological waste treatment

Pilot projects & design engin.  
Supervision and analytics  
Optimisation



### Landfills

Design engineering  
Supervision and aftercare  
Reuse concepts

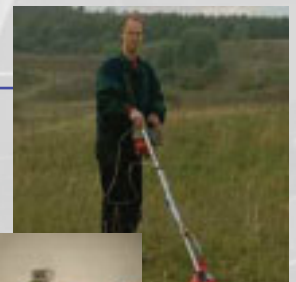

### Contaminated sites

Site investigation  
Risk assessment  
Design engineering for clean up operations

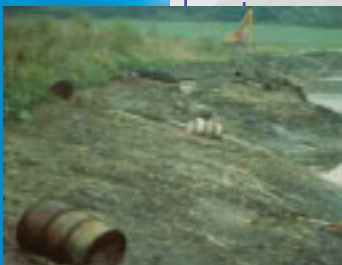

## Wasteconsult International





### Mechanical biological waste treatment

#### Design engineering and optimisation of MBT plants

The staff of **Wasteconsult** is and has been significantly involved in research, plant design and optimisation of the mechanical biological waste treatment and its emission control. Based on this, we design and optimise MBT plants for you.



#### Pilot projects

We supplement our experience by own pilot tests and research results in the area of MBT optimisation and emission measurement & treatment. We have developed and tested what others just know from books!

#### Sampling and analytics

Waste treatment needs a permanent control and adaptation to the varying waste composition and changed boundary values.

**Wasteconsult** offers an extensive attendance of your MBT beginning with sampling and ending with the evaluation of the analytical results. This is a precondition for stable and economically operation of your MBT.

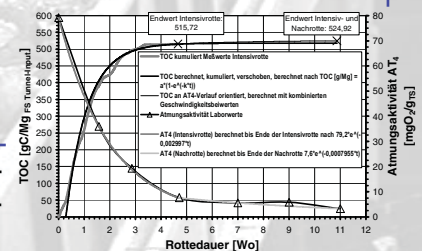

#### Emission measurement

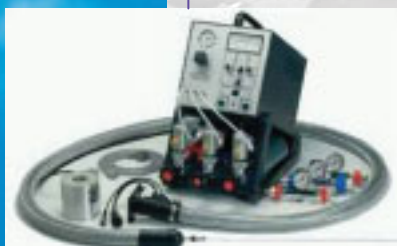

Do you want to know what gets into your exhaust gas treatment and what is in its output? Do you want to adjust the MBT for an economically optimised operation of a regenerative thermal oxidation of the exhaust gas? We have experience with the measurement technique and accomplishment of long continuous emission measurements. We can analyse your biogas from the digestion or your landfill gas for the main and trace components.

At **Wasteconsult** you are in best hands for design engineering, optimisation and analytics in all aspects of MBT!





### Landfills and contaminated land

#### Design engineering

The **Wasteconsult** staff has extensive experience in the whole area of design engineering, bid invitation and construction supervision of

- Landfill covers and liners
- Operation and emplacement concepts
- Gas collection and treatment
- Leachate and groundwater collection and treatment

**Our know how about MBT landfills is unique.**



#### Monitoring, aftercare and reuse

Landfills and contaminated sites need a long lasting supervision. Wasteconsult designs your aftercare measures and monitors groundwater, leachate, gas and the landfill installations. Furthermore we propose possibilities for the reuse of the landfill area. Depending on the legal regulations (financial support) in your country, wind energy or photovoltaics might be an attractive solution. Our new concept **DepoSolar**<sup>®</sup> combines the function of landfill cover sealing and solar electricity production.



#### In-situ stabilisation

An important step to minimise the aftercare duration and costs is the active control of closed landfill sectors. This starts with leachate re-infiltration to enhance the gas production and the anaerobical stabilisation. When the gas yield or the methane concentration are too low, the time has come for a methane oxidising cover or for the start of in-situ aeration of the landfill. This will accelerate the stabilisation of the landfill significantly and save money because of the reduced leachate contamination and the shortened aftercare phase.



### Contaminated land

Based on the long lived experience of our staff we can offer the whole package of engineering services for the remediation of contaminated land:

- Site investigation and risk assessment
- Design of clean up operations
- Construction supervision & control of occupational security

**Take advantage of our experience!**



# Content

## I Introduction and overview

- Address of welcome; Reduce; re-use; recycle – a global necessity.** 1  
*Kühle-Weidemeier, M.*
- Future is not an extrapolation of the past (CK Prahalad) – On the way to a global resource management.** 15  
*Birnstengel, B., Alwast, H., Haeusler, A.*
- The new waste framework directive and next steps in EU waste policy.** 26  
*A. Versmann*

## II Current situation and implementation of the waste framework directive

- Germany.** 38  
*Jaron, A.*
- Belgium.** 45  
*Wante, J.*
- Greece confronted with the new waste framework directive.** 54  
*Karagiannidis, A.*
- Waste Management in Romania: Past and present.** 61  
*Rada, E. C., Apostol, T., Ragazzi, M., Istrate, I. A.*
- Endeavours of Poland to reach a high standard of municipal waste management** 279  
*Rybackzewska-Blazejowska, M.*

## III Avoidance and waste management concepts

- Waste Producers' Duty of Care under European Community Law** 73  
*Mott, R. M..*
- Optimization model of integrated MSW management.** 86  
*Nondek, L.*
- Evolution and optimization of a residential source separation scheme in a 15 year history: Quality and efficiency in the North Italian experience.** 98  
*Garaffa, C., Mariotto, L., Moriando, A., Roverato, C.*



<b>Municipal waste management in Zagreb; Vienna or Neapel model?</b> <i>Potocnik, V.</i>	110
---	-----

<b>Strategy and implementation plan for Integrated Solid Waste Management in Tehran.</b> <i>Amir, S., Harati, N.</i>	122
---	-----

#### **IV Management of special waste flows**

<b>Hazardous waste classification and re-use (end of waste) by the new waste framework directive, CLP and REACH regulations.</b> <i>Malicka, M.</i>	130
--	-----

<b>Improvement of hazardous waste management in Turkey through introduction of a web-based system for data collection and quality control.</b> <i>Küchen, V., N.N.</i>	138
---	-----

<b>DIRECT-MAT – Developing best practise on recycling of safe disposal of road materials in Europe.</b> <i>Mollenhauer, K., Arm, M., Descantes, Y., de la Roche, C., Pihl, K. A., Gaspar, L., de Lurdes Antunes, M., De Bock, L., McNally, C.</i>	151
--	-----

<b>Legal requirements and practise of the transport of healthcare waste within the European Union.</b> <i>Brück, K., Ramalho, P.</i>	162
---	-----

#### **V Recovery of plastics and other types of high calorific waste**

<b>Plastic flows from production to (optimized) recovery.</b> <i>Fehringer, R.</i>	171
---	-----

<b>Evaluation of system costs for the use of plastics with regard to disposal costs.</b> <i>Schu, R.</i>	180
---	-----

<b>North London Waste Authority – Waste Services &amp; Fuel Use Procurement.</b> <i>Ling, E., Judson, T.</i>	194
---	-----

<b>Formula for energy efficiency – meaning and application.</b> <i>Hauer, W.</i>	209
---	-----

#### **VI Increasing energy efficiency in waste to energy processes**

<b>Increasing energy efficiency: A plant manufactures view.</b> <i>Maciejewski, M.</i>	216
---	-----

---

<b>Achieving a high energy efficiency at the EBS power plant Stavenhagen.</b> <i>Plepla, K.-H.</i>	227
---	-----

## **VII Material specific waste treatment**

<b>French national household waste characterisation survey.</b> <i>Fangeat, E.</i>	243
---	-----

<b>Sensor based sorting: A key technology for sustainable waste management.</b> <i>Pretz, T.</i>	250
---	-----

<b>Comparison of methods for the treatment of mixed municipal waste from households.</b> <i>Mitterwallner, J., Himmel, W.</i>	259
--	-----

<b>Pre-processing of municipal solid waste before anaerobic digestion – CAPEX and OPEX as model calculation.</b> <i>Langen, M.</i>	271
---	-----

## Note

The proceedings were arranged by Wasteconsult international Dr. Kuehle-Weidemeier with high accuracy. Nevertheless, errors cannot be fully excluded. Wasteconsult and the editors are not liable or responsible for the correctness of the information in this book. The authors take responsibility for their content.

If a brand or trade name was used, there might be trademark rights valid, even if they were not explicitly stated.

The proceedings contain complicated technical terms. Wasteconsult does not take any liability for the correctness of the translation. Please check the plausibility of the content you are reading.

# Content

## I Introduction and overview

- Address of welcome; Reduce; re-use; recycle – a global necessity.** 1  
*Kühle-Weidemeier, M.*
- Future is not an extrapolation of the past (CK Prahalad) – On the way to a global resource management.** 15  
*Birnstengel, B., Alwast, H., Haeusler, A.*
- The new waste framework directive and next steps in EU waste policy.** 26  
*A. Versmann*

## II Current situation and implementation of the waste framework directive

- Germany.** 38  
*Jaron, A.*
- Belgium.** 45  
*Wante, J.*
- Greece confronted with the new waste framework directive.** 54  
*Karagiannidis, A.*
- Waste Management in Romania: Past and present.** 61  
*Rada, E. C., Apostol, T., Ragazzi, M., Istrate, I. A.*

## III Avoidance and waste management concepts

- Waste Producers' Duty of Care under European Community Law** 73  
*Mott, R. M.*
- Optimization model of integrated MSW management.** 86  
*Nondek, L.*
- Evolution and optimization of a residential source separation scheme in a 15 year history: Quality and efficiency in the North Italian experience.** 98  
*Garaffa, C., Mariotto, L., Moriando, A., Roverato, C.*
- Municipal waste management in Zagreb; Vienna or Neapel model?** 110  
*Potocnik, V.*



<b>Strategy and implementation plan for Integrated Solid Waste Management in Tehran.</b>	122
<i>Amir, S., Harati, N.</i>	

#### **IV Management of special waste flows**

<b>Hazardous waste classification and re-use (end of waste) by the new waste framework directive, CLP and REACH regulations.</b>	130
<i>Malicka, M.</i>	

<b>Improvement of hazardous waste management in Turkey through introduction of a web-based system for data collection and quality control.</b>	138
<i>Küchen, V., N.N.</i>	

<b>DIRECT-MAT – Developing best practise on recycling of safe disposal of road materials in Europe.</b>	151
<i>Mollenhauer, K., Arm, M., Descantes, Y., de la Roche, C., Pihl, K. A., Gaspar, L., de Lurdes Antunes, M., De Bock, L., McNally, C.</i>	

<b>Legal requirements and practise of the transport of healthcare waste within the European Union.</b>	162
<i>Brück, K., Ramalho, P.</i>	

#### **V Recovery of plastics and other types of high calorific waste**

<b>Plastic flows from production to (optimized) recovery.</b>	171
<i>Fehringer, R.</i>	

<b>Evaluation of system costs for the use of plastics with regard to disposal costs.</b>	180
<i>Schu, R.</i>	

<b>North London Waste Authority – Waste Services &amp; Fuel Use Procurement.</b>	194
<i>Ling, E., Judson, T.</i>	

<b>Formula for energy efficiency – meaning and application.</b>	209
<i>Hauer, W.</i>	

#### **VI Increasing energy efficiency in waste to energy processes**

<b>Increasing energy efficiency: A plant manufactures view.</b>	216
<i>Maciejewski, M.</i>	

<b>Achieving a high energy efficiency at the EBS power plant Stavenhagen.</b>	227
<i>Plepla, K.-H.</i>	

---

**VII Material specific waste treatment**

<b>French national household waste characterisation survey.</b> <i>Fangeat, E.</i>	243
<b>Sensor based sorting: A key technology for sustainable waste management.</b> <i>Pretz, T.</i>	250
<b>Comparison of methods for the treatment of mixed municipal waste from households.</b> <i>Mitterwallner, J., Himmel, W.</i>	259
<b>Pre-processing of municipal solid waste before anaerobic digestion – CAPEX and OPEX as model calculation.</b> <i>Langen, M.</i>	271
<b>Endeavours of Poland to reach a high standard of municipal waste management</b> <i>Rybackiewska-Blazejowska, M.</i>	279

## Note

The proceedings were arranged by Wasteconsult international Dr. Kuehle-Weidemeier with high accuracy. Nevertheless, errors cannot be fully excluded. Wasteconsult and the editors are not liable or responsible for the correctness of the information in this book. The authors take responsibility for their content.

If a brand or trade name was used, there might be trademark rights valid, even if they were not explicitly stated.

The proceedings contain complicated technical terms. Wasteconsult does not take any liability for the correctness of the translation. Please check the plausibility of the content you are reading.

---

# Reduce; re-use; recycle – a global necessity

**Matthias Kuehle-Weidemeier**

Wasteconsult International

## **Abstract**

With regard to the shortage and price increase of resources it is important to break new ground in waste management to support sustainable methods of waste treatment in the future.

The following article gives an overview of the availability and the use of raw materials (fossil fuels, metallic and non-metallic) in some important countries in the world. Also, it is shown how CO<sub>2</sub>-emissions can be reduced by recycling and valuable resources can be saved for future generations.

Today's methods of waste treatment (mechanical-biological-treatment or waste incineration) are evaluated concerning their feasibility for sustainable waste management.

Finally recommendations on how to reach a sustainable waste management are presented.

## **Keywords**

waste management, resources, raw materials, waste treatment, MBT, incineration

## **1 Introduction**

The approaching exhaustion of many raw materials and expanding demand for resources due to fast growth of world population and increasing prosperity in many developing countries are a challenge for the world economy and will become a driving factor for enhanced waste treatment / material recovery technology. Quantity and quality of recovered resources from residual waste depend on the kind of waste treatment. Mechanical-biological treatment (MBT) and incineration are the dominant treatment technologies for residual waste and have to prove their feasibility for sustainable waste and resource management.

## **2 Population growth, consumption of raw materials and available resources**

### **2.1 Population development and consumption of raw materials**

The world population will grow from 6.7 billions now (data 2007) to round about 9.1 billion in 2050 (UN, 2009). That corresponds to an average annual growth of 56 millions.



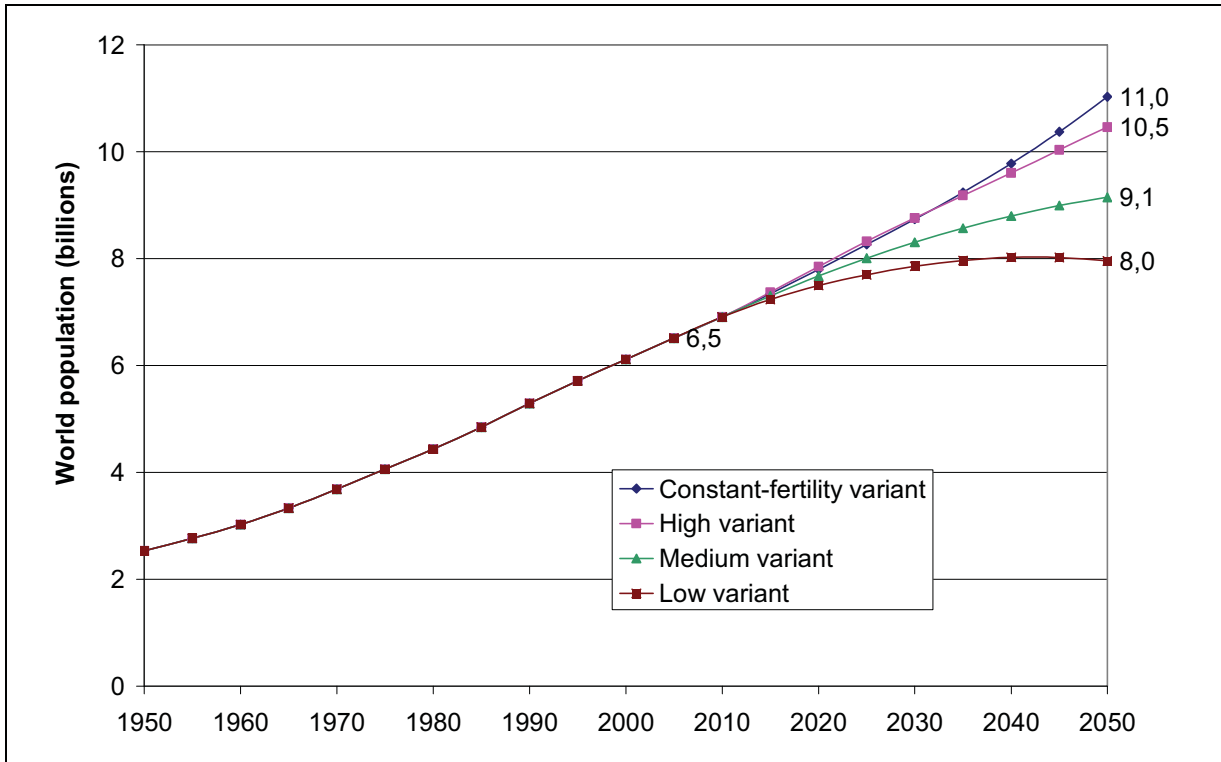

Figure 1: Different scenarios of world population growth (data source: UN, 2009)

The German Foundation for World Population (DSW) reports on their web site a current world population growth of about 81 million people per year. This is nearly as much as the total number of Germany’s inhabitants.

Developing and emerging countries show the highest rates of population growth but there are huge differences between the countries. Figure 2 shows the prediction (medium variant) for China and India compared to Germany. Due to their high number of inhabitants and high economic growth, China and India have a high relevance for the topics discussed in this paper.

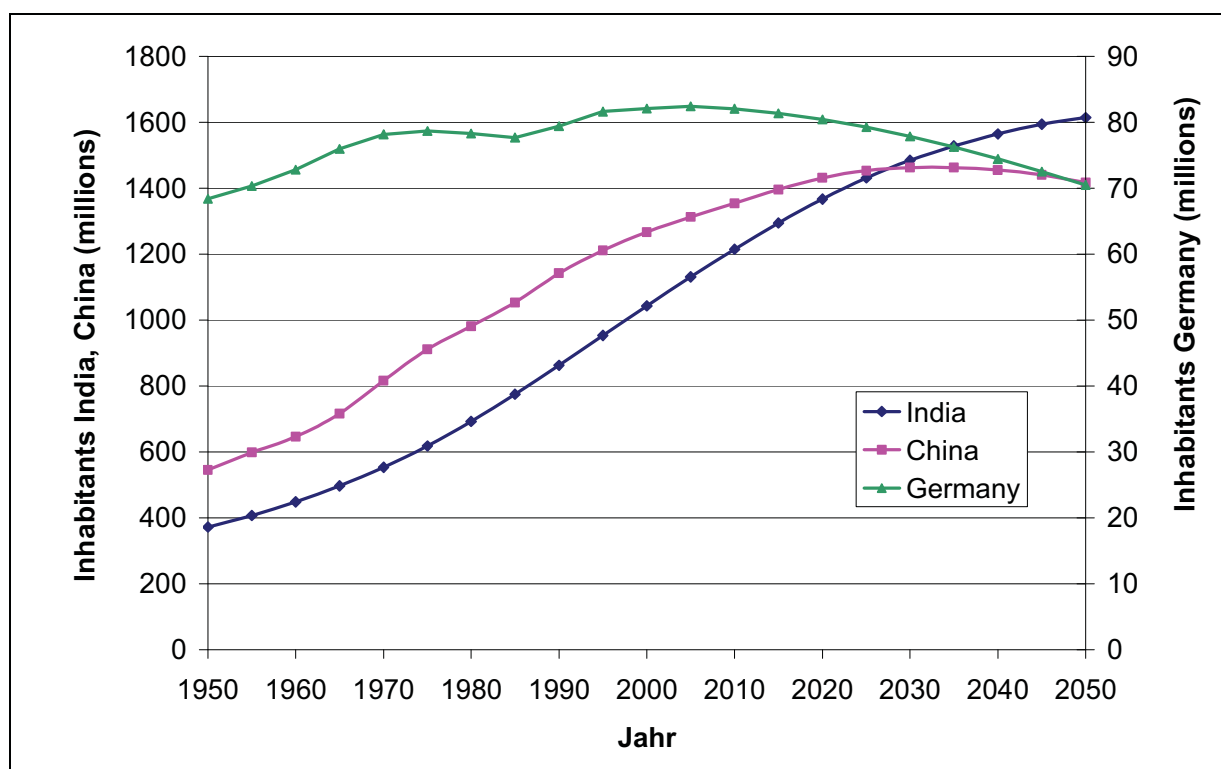

Figure 2: Population development in India, China and Germany, med. variant (data: UN, 2009)

Figure 3 presents the per capita consumption of selected and all resources in different countries. The total includes Biomass. China is already going to approach the average per capita consumption of fossil fuels of the European Union.

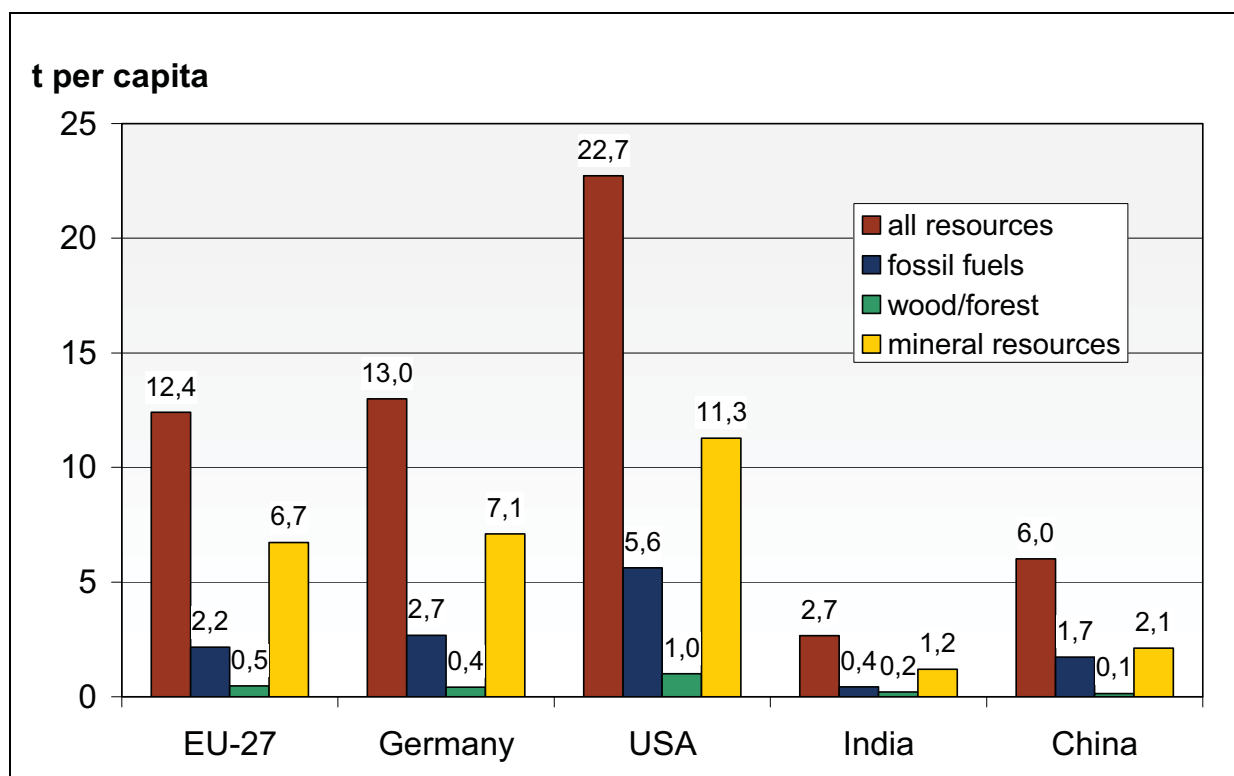

Figure 3: Per capita consumption of resources in different countries (data source: SERI, 2009)

## 2.2 Important definitions on material reach

For a proper description of the reach of materials (remaining time of availability), some terms need to be defined to avoid misunderstandings due to a different use of these terms in colloquial language. Definitions are according to BARTHEL (1999). These definitions are applied in chapter 2.3 and 2.4 of this article.

**Reserve:** Those known raw material sources (e.g. ore) that can be economically produced under current market price conditions.

**Resource:** Proven (natural) material sources where production effort is too high for an economical material production. When the market price increases or cheaper production technologies are developed, resources can become reserves.

**Static reach:** Time that reserves last (reach of reserves) at a constant production rate

Reach data in chapter 2.3 and 2.4 is based on a constant production rate. An increase of the production rate would shorten the reach.

## 2.3 Reach of fossil fuels and Uranium

The reach of the non renewable energy resources is important to consider in long term waste management concepts as it will influence the value of refuse derived fuels (RDF) and recovered plastics because oil is the basic raw material for plastics. Oil reserves just last 42 years even under constant production.

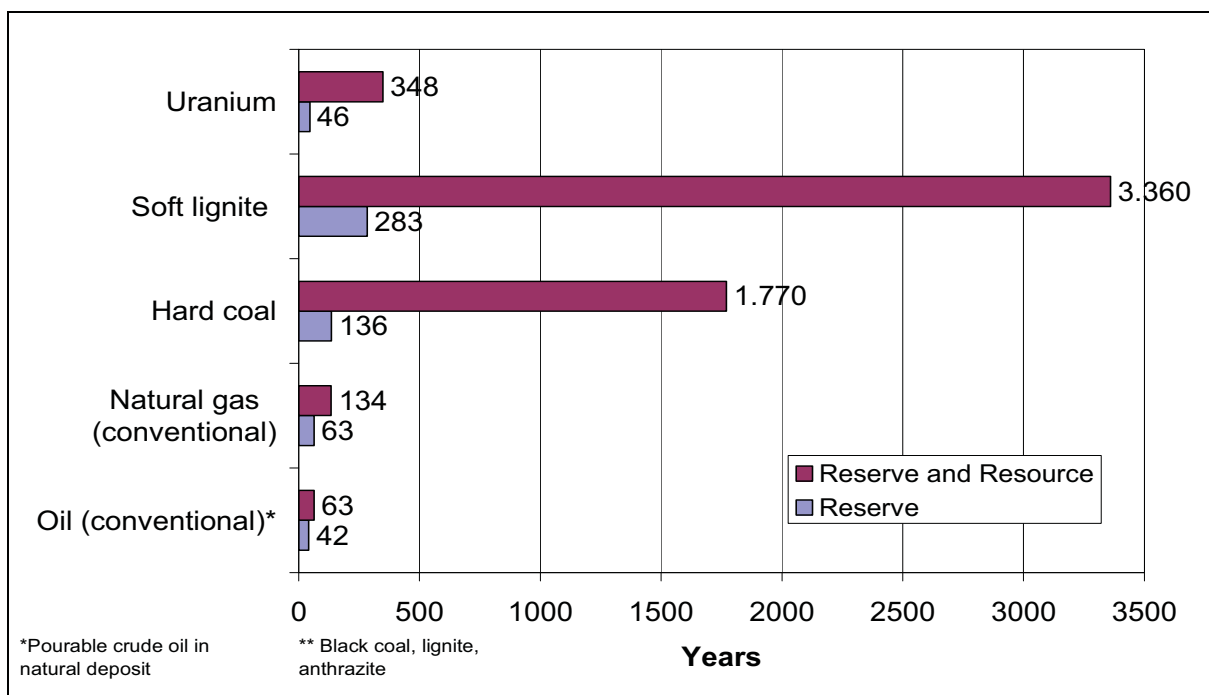

Figure 4: Reach of energy raw materials (data source: BGR 2007)

## 2.4 Reach of metals and minerals

The reach of metallic and mineral raw materials is not as present as fossil fuels in the public discussion although the reach of many of those irreplaceable materials is even shorter than the reach of oil.

Besides materials that are used for the production of goods, the reach of Phosphate, that is essential for the industrial agriculture and hence for the alimentation of the rapidly growing earth population is only 122 years (BARDT 2008).

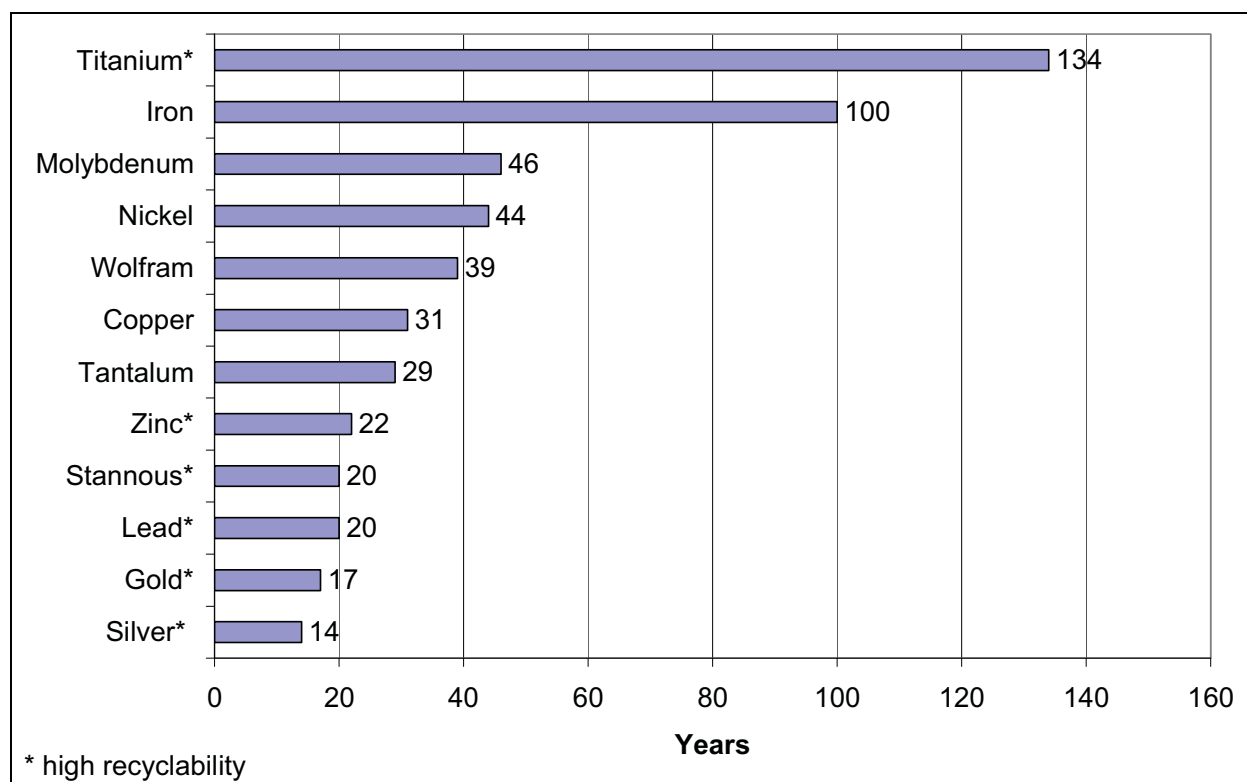

Figure 5: Reach of metallic reserves (DATA SOURCE: BARDT 2008)

The institute of German economy (Institut für Wirtschaft, IW) in Cologne (Köln) published a raw material supply risk list of materials that have a reach of less than 30 years. In spite of their short reach, gold, silver, zinc, stannous and lead do not appear in this list because of their high recyclability. The supply with chrome, molybdenum, columbium (niobium) and metals from the platinum group is classified as very critical in the list. This considers not just the reach but also the situation, that the supply with those metals depends on only 3 countries and 3 companies (BARDT, 2008).

The situation in metal supply is reflected by price development for metallic raw materials that increased by 235% from 2005 to 2008. The price increase of iron ore and steel scrap was even 385% (BARDT 2008). The current massive price drop can be assumed as a temporary event.

## 2.5 Price development of secondary raw materials

The prices of plastic reclaim (re-granulate) increased significantly in the last years too (50-100% from summer 2003 to summer 2008). With the beginning economical crisis in the second term of 2008 massively declined. This endangers the recycling industry seriously.

The situation of trading prices for used paper is similar:

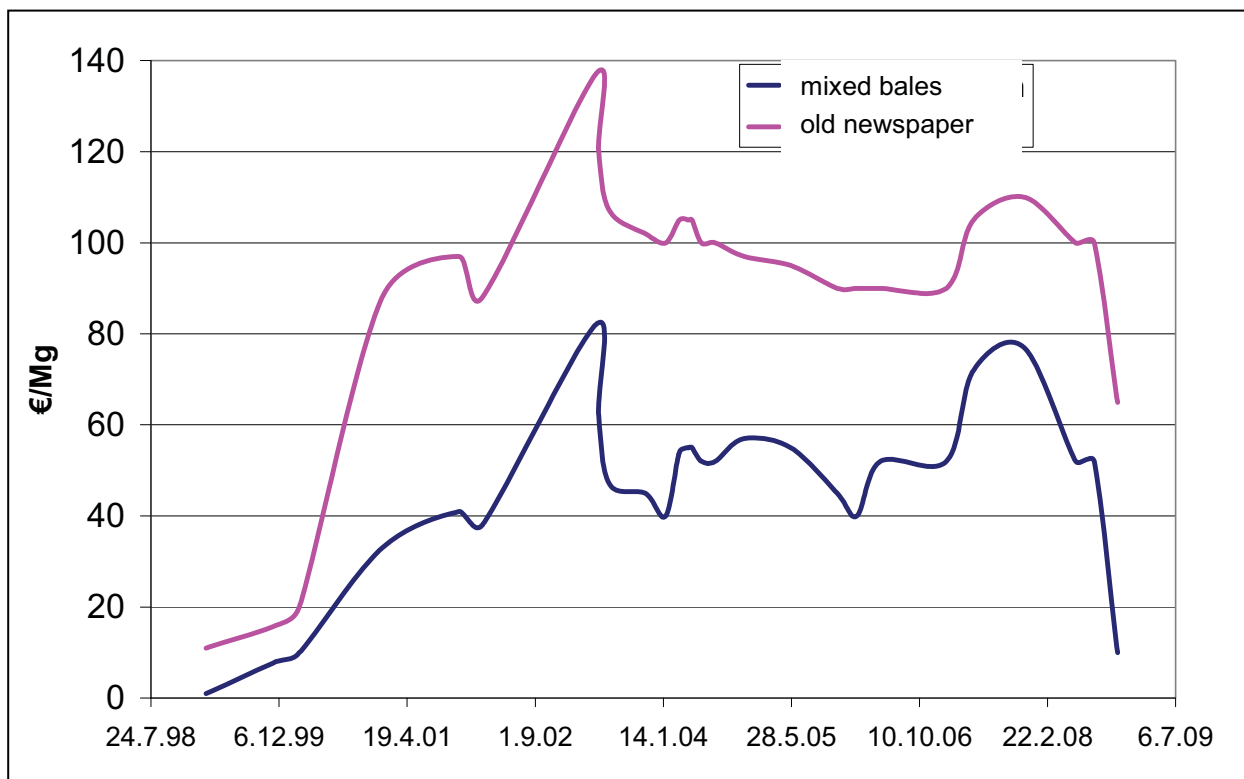

Figure 6: Prices of 2 used paper qualities (data: numerous issues of EUWID Recycling und Entsorgung)

## 2.6 Reduction of CO<sub>2</sub>- emissions by recycling

Recycling is important for climate protection too. By order of INTERSEROH, a German recycling company, Fraunhofer-Institute UMSICHT compared CO<sub>2</sub>-emissions caused by the production of primary and secondary materials.

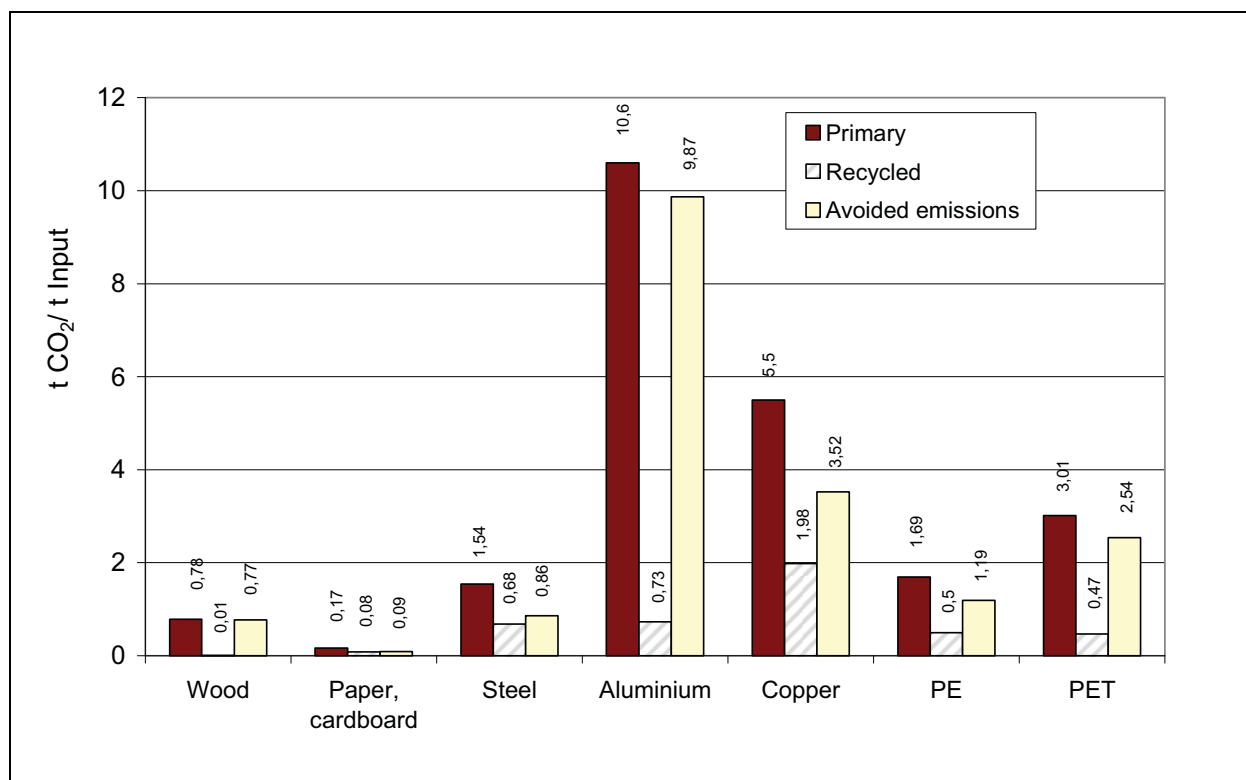

Figure 7: CO<sub>2</sub>-emissions by primary and secondary material production and avoided emissions by recycling (data: Interseroh, Umsicht, 2008)

Figure 7 shows that recycling saves an enormous amount of CO<sub>2</sub> emissions and thus energy. For example, copper recycling saves 36%, steel recycling 56%, PE recycling 70%, PET recycling 85% and aluminium recycling even 95% compared to primary material production.

The calculated emissions of the recycling process consider collection, transport and the recycling process itself. Considered transport distances to the recycling facilities are based on the true situation. In case of PET this is the transport to south east Asia. It has to be mentioned, that plastics, paper and wood are only feasible for a small number of recycling cycles. Paper fibres can be re-used 5 - 7 times.

### 3 Feasibility of waste treatment technologies for the requirements of sustainable waste management

#### 3.1 Treatment of residual waste in Germany

Landfilling of non inert waste is not permitted in Germany. Packages and native organic waste are separately collected and recycled. The remaining residual waste is treated by incineration (about 80%) and about 20% mass-% by mechanical-biological treatment (KÜHLE-WEIDEMEIER, 2005).



## **3.2 Thermal waste treatment (incineration)**

### **3.2.1 „Classic“ incineration of residual waste**

Conventional waste incinerators are an approved and very reliable technology for waste treatment. If they are combined with a state of the art exhaust gas treatment system, there is not much reason to be concerned about their toxic emissions.

Depending on it's quality (leaching test) incinerator bottom ash is used as construction material (mainly for roads) or landfilled. The long term behaviour of incinerator bottom ash is subject of a controversial discussion. The main concern is that possibly a real long term stability (immobilisation of heavy metals) is possibly not given. That is why some opponents call roads constructed with incinerator bottom ash "line landfills".

A part of the exhaust gas cleaning residues is highly toxic and gets stored in subsurface hazardous waste landfills.

Ferrous metals are removed from incinerator residues by magnetic separation. These metals are heavily oxidised. Non-ferrous metals are irrecoverably lost in the bottom ash.

Another product of incineration is energy. That is why incinerators are sometimes called waste to energy plants (sounds nicer). Municipal solid waste [MSW] (with or without source separated collection) has many components with a low calorific value like water (humidity) soil and much more. Hence, the yield of energy is low. Some incinerators are badly located in areas without demand for the produced heat. In some countries the calorific value of the waste is so low that oil is needed to support the combustion process. In this case, waste to energy converts to energy to waste.

### **3.2.2 Co-generation plants for refuse derived fuel (RDF)**

Co-generation plants that are operated with (pre-treated) high calorific waste (RDF) are real power stations that can be truly called waste to energy plants. They are usually connected to industrial plants that allow using the produced heat (steam) and the electricity too.

### **3.2.3 Evaluation and future relevance for sustainable waste management**

Concerning the conservation of resources, waste incinerators are energy and resource destruction plants. Table 1 reveals how much energy is lost if only the energy represented by the calorific value is recovered.

Table 1: Calorific value and energy equivalent (cal. value + energy effort for production) of some plastic materials (Reimann 1988)

Material	Calorific value [kJ/kg]	Energy equivalent [kJ/kg]
Polyethylen (PE)	43,000	70,000
Polypropylen (PP)	44,000	73,000
Polystrol (PS)	40,000	80,000
PVC hard	18,000	53,000

Only ferrous metals can be recovered from the incineration process. Hence, in a sustainable waste and resource management concept, incineration is feasible only for the treatment of those waste components that can not be recycled or when recycling effort (e.g. energy consumption) exceeds the benefit of recycling. That has been the case with the majority of the MSW in the past. That is why incineration as an expensive but reliable technique is so widespread in Germany.

Innovations and significant cost reductions in waste processing and sensor based waste sorting has changed this situation as well as the approaching shortage of raw materials. After the current economical and raw material price crisis more and more waste components will be picked out by sorting machines. Besides the ecological benefit, this saves cost for expensive treatment like incineration and often even creates a positive income. Some waste management societies have already voluntarily installed sensor based sorting units because they it pays off. Step by step there will be less waste that will be incinerated in Germany, resulting in increasing incinerator over capacities. This development might be delayed by price dumping of incinerator operators.

### 3.3 Mechanical-biological treatment (MBT)

#### 3.3.1 Current situation

Figure 9 shows the average mass-balance of the German MBTs. The amount of material recovery in these plants is not very high. From the total of 4.9 million Mg (tons) per year 127,000 Mg ferrous metal and 9,000 Mg non ferrous metals are recycled. The vast majority (2 million Mg) of MBT output goes to energy recovery (incineration) and 1 million Mg are landfilled.

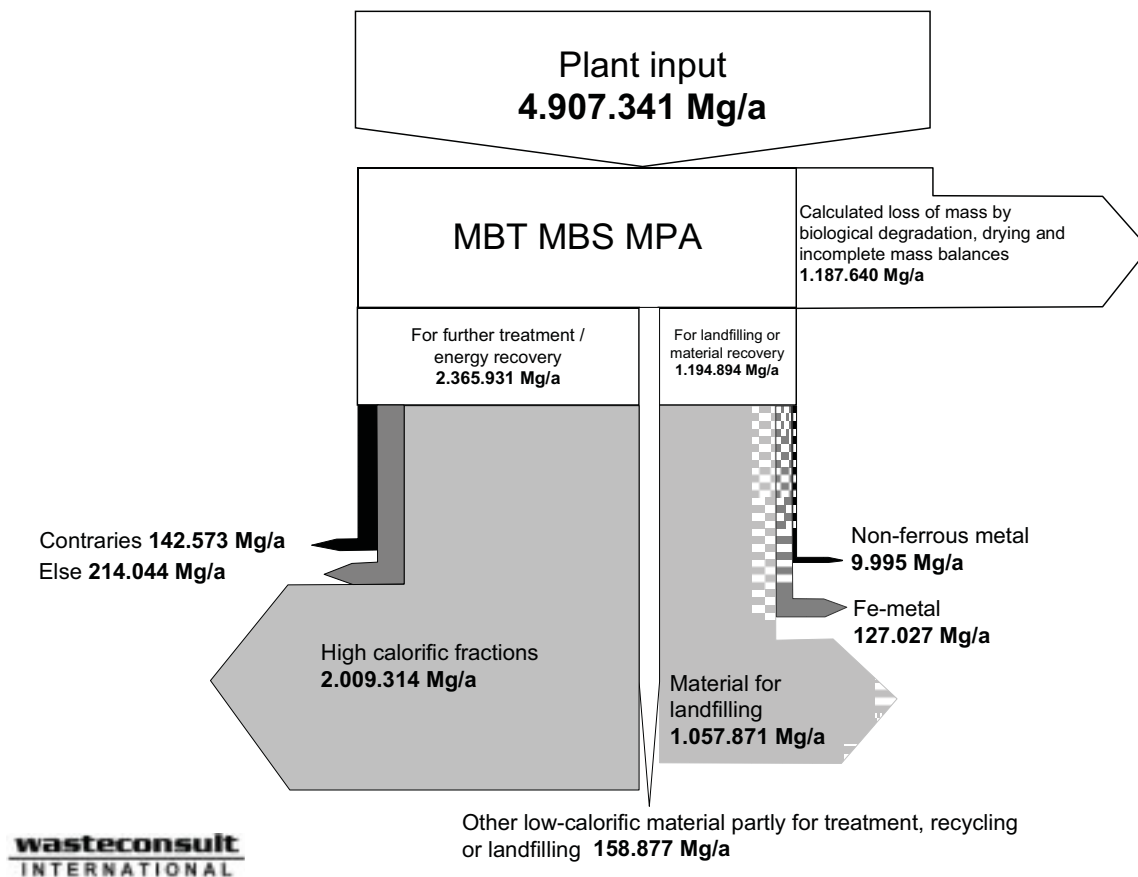

Figure 8: Mass-balance of the German MBTs (Kühle-Weidemeier et al., 2007)

Only anaerobic MBT processes produce energy that covers at least their own energy demand. The other MBT processes just consume energy.

### 3.3.2 Evaluation

Currently, MBT wastes energy and resources although the material and energy recovery potential is already higher than with conventional incinerators. Even the input of the biological treatment step contains valuable resources that could be picked out (paper, wood, plastics, minerals ...), like it is already done in a very few plants.

### 3.3.3 Enhancement and future potential of MBT

Big progresses in sensor based sorting makes installation of such units in MBT plants attractive. They are applicable to the coarse fraction as well as to the fine fraction. Best conditions for such applications exist at plants with wet mechanical treatment steps or biological / physical drying. MBT will develop to MRFs with integrated biological treatment.



*Figure 9: Various fractions from a biological and wet mechanical treatment step of an MBT*

The (former) landfill fraction of MBTs with wet mechanical treatment steps of wet anaerobic treatment does not necessarily have to be landfilled. Figure 9 shows that useable mineral and organic fractions could easily be extracted.

The conception of MBT as a material specific waste treatment technology offers best requirements for a sustainable, resource optimised waste management but it needs to be consequently improved with the focus on material separation and recovery.

## **4 Resource recovery from landfills**

Concepts for material recovery from landfills have come back on the agenda, for example VISVANATHAN ET AL., 2007.

Currently, landfill mining is still too expensive in Europe but with increasing prices of raw materials this might change in a medium range of time. Faulstich (2008) compiled data about recoverable resources in German landfills:

Table 2: Resources in German landfills (Data from Faulstich, 2008)

<b>Deutschland</b>	Deponierte Siedlungsabfälle	Deponierte Massenabfälle	Deponierter Klärschlamm	
Gesamtmenge	960	50	>> 10	Mio. Mg
Fe- + NE-Metalle	32			
Zink		70.000		Mg
Blei		25.000		Mg
Phosphat			1	Mio. Mg

## 5 Summary and recommendations

Shrinking natural resources, fast growth of the world population and increasing prosperity in emerging and developing countries requires consequently resource optimised acting in general and especially in waste management. A massive increase of the share of materials recovered from waste is necessary. This would enhance material supply and save lots of energy (CO<sub>2</sub>-emissions) too. Resource recovery means climate protection.

Enhanced MBTs and sensor based waste sorting plants must become the heart of a sustainable, material specific waste management system. Current MBTs are the first step on this very promising way. MBT will develop to MRF with integrated biological treatment or pure material separation.

Incineration does not meet the requirements of a sustainable, resource optimised waste management concept, because the energy that was spent for the production of the materials that are used as fuels is completely lost in the incineration process. Precious waste components like non-ferrous metals are irrecoverably lost in the incinerator ash. A significant share of the waste that is expensively incinerated at the moment will be cheaper recovered in the future. Hence, there will be less input for incinerators. Incineration will step by step lose its importance, although there will always be demand for some incineration capacity because total recovery and recycling is not possible. Countries that are going to design their waste treatment concept should consider this development.



## 6 Literature

- |  |      |   |
|--|------|---|
| ASA-Beirat   | 2006 | MBA und das Ziel 2020. Arbeitsgemeinschaft Stoffspezifische Abfallbehandlung (ASA e.V.), pdf-Dokument.  |
| Bardt, H.  | 2008 | Sichere Energie- und Rohstoffversorgung. Herausforderung für Politik und Wirtschaft? Deutscher Instituts-Verlag, Köln, ISBN 978-3-602-24133-0.  |
| Barthel, F.  | 1999 | See the world from a wider perspective. Commodity top news. Fakten, Analysen, wirtschaftliche Hintergrundinformationen. No. 6. Bundesanstalt für Geowissenschaften und Rohstoffe (BGR).   |
| Biebeler, H., Mahammadzadeh, M. und Selke, J.-W.           | 2008 | Globaler Wandel aus Sicht der Wirtschaft. Chancen und Risiken, Forschungsbedarf und Innovationshemmnisse. Deutscher Instituts-Verlag, Köln, ISBN 978-3-602-14791-5  |
| Brammer, F.  | 1997 | Rückbau von Siedlungsabfalldeponien. Schrittfolge und Entscheidungskriterien bei Planung und Ausführung. Dissertation am Fachbereich für Bauingenieur- und Vermessungswesen der TU Braunschweig.  |
| Bundesanstalt für Geowissenschaften und Rohstoffe (Hrsg.); | 2008 | Reserven, Ressourcen und Verfügbarkeit von Energierohstoffen 2007. Jahresbericht 2007. pdf-Dokument, <a href="http://www.bgr-bund.de">www,bgr-bund.de</a>   |
| Deutsche Stiftung Weltbevölkerung                          | 2009 | <a href="http://www.weltbevoelkerung.de/info-service/weltbevoelkerungsuhr.php?navanchor=1010037">http://www.weltbevoelkerung.de/info-service/weltbevoelkerungsuhr.php?navanchor=1010037</a>   |
| Faulstich, M.  | 2008 | Abfallwirtschaft und Ressourcenschutz. Welchen Beitrag leistet Recycling zur Nachhaltigkeit? Präsentation zum Rohstoffkongress 2008, Berlin.  |
| Fraunhofer Institut UMSICHT, INTERSEROH AG (Hrsg.)         | 2008 | Recycling für den Klimaschutz. Ergebnisse der Studie von Fraunhofer UMSICHT und INTERSEROH zur CO <sub>2</sub> -Einsparung durch den Einsatz von Sekundärrohstoffen, Broschüre.   |
| Kühle-Weidemeier, M.                                       | 2005 | Bedarf, Konstruktionsgrundlagen und Betrieb von Deponien für mechanisch-biologisch behandelte Restabfälle in Deutschland. Veröffentlichungen des Institutes für Siedlungswasserwirtschaft und Abfalltechnik der Universität Hannover, Heft 127. ISBN 3-921-421-57-8 |



- |  |      |  |
|--|------|--|
| Kühle-Weidemeier, M.; Langer, U.; Hohmann, F.              | 2007 | Anlagen zur mechanisch-biologischen Restabfallbehandlung. Schlussbericht. By order of the German Environment Agency (Umweltbundesamt) UFOPLAN 206 33 301   |
| SERI (Sustainable Europe Research Institute)               | 2009 | <a href="http://www.materialflows.net/mfa/">http://www.materialflows.net/mfa/</a><br>Visited 10.03.2009  |
| UN (United Nations)  | 2009 | World Population Prospects: The 2008 Revision. Population Division of the Department of Economic and Social Affairs of the United Nations Secretariat, <a href="http://esa.un.org/unpp">http://esa.un.org/unpp</a>                 |
| Visvanathan, C.; Norbu, T.; Chiemchaisri, C.; Charnnok, B. | 2007 | Applying Mechanical Pre-Treatment and Landfill Mining. Approach in Recovering Refuse Derived Fuel (RDF) from Dumpsite Waste: Thailand Case Study. In: Kühle-Weidemeier, M. (Hrsg.): International Symposium MBT 2009. Proceedings. |
| Wuttke, J. Dr.   | 2005 | Grundzüge der Abfallwirtschaft in Deutschland. In: Hösel, Bilitewski, Schenkel and Schnurer (Hrsg.) Müllhandbuch, Bd. 1, 0169, Erich Schmidt Verlag, Berlin.   |

**Author's address:**

Dr.-Ing. Dipl.-Geogr. Matthias Kühle-Weidemeier

Wasteconsult international

Robert-Koch-Str. 48 b

D-30853 Langenhagen

Telefon +49 511 23 59 383

E-Mail: [info { at } wasteconsult . de](mailto:info@wasteconsult.de)

Website: [www.wasteconsult.de](http://www.wasteconsult.de)

# Waste-to-Resources 2011

## 4<sup>th</sup> International Symposium MBT & MRF, Mechanical Biological Waste Treatment, Waste Sorting and Recovery Technology

Hanover, 24<sup>th</sup>-26<sup>th</sup> of May 2011



2009: 340 Participants from 41 countries. Previous exhibitors:



# **“Future is not an extrapolation of the past” (CK Prahalad) – The way to global resource management**

**Bärbel Birnstengel – Holger Alwast – Arno Häusler**

Prognos AG, Berlin

## **Abstract**

Based on own Prognos analyses the article shows the so far achieved recovery rates for selected waste streams within the 27 EU member states as well as the still existing resource potential - a potential that can also contribute significantly to climate protection.

Looking back from the future the article describes the major challenges of our time and for our future and develops visions for a global resource management system.

## **Inhaltsangabe**

Auf der Grundlage eigener Forschungsergebnisse zeigt der Beitrag für ausgewählte Stoffströme den bisher innerhalb der EU 27 Mitgliedsstaaten erreichten Verwertungsstand und das noch bestehende Ressourcenpotenzial. Ein Potenzial, das auch einen bedeutenden Beitrag zum Klimaschutz leisten kann.

Über einen fiktiven Blick aus der Zukunft zurück beschreibt der Beitrag die großen Herausforderungen der Gegenwart und Zukunft und entwickelt Visionen für ein globales Ressourcenmanagement.

## **Keywords**

waste, global resource management, climate protection, secondary raw materials, resource conservation, waste stream, Life Cycle Analysis (LCA), sustainability

Abfall, Globales Ressourcenmanagement, Klimaschutz, Sekundärrohstoffe, Ressourcenschonung, Abfallstoffstrom, Life Cycle Analysis (LCA), Nachhaltigkeit

## **1 Reykjavík 2040**

It is the year 2040. In Reykjavík, the International Energy and Resources Organisation (IERO) is celebrating its 20<sup>th</sup> anniversary.

With great anticipation, many international guests and representatives are awaiting the commemorative speech of the General Secretary – let's say her name is Ms. Ingibjörg Önnudóttir - reviewing 20 years of IERO history and the eventful 15 years leading up to its establishment.



## 2 Crisis as an Opportunity

The new millennium did not get off to a good start. The “dark year” 2009 had plunged the world economy into a global financial and economic crisis. The European resource economy – back then it was still misleadingly called ‘waste management’ – was also deeply affected by this crisis. Plummeting prices in the secondary raw material markets, drastically reduced demand for secondary raw materials, collapsing production capacities, and heavily decreasing industrial and commercial waste volumes all resulted in significant revenue and turnover losses and burdened waste management companies for many years to come. The crisis of the banking sector, which deteriorated conditions on the financial markets, became an additional problem.

At the end of the millennium’s first decade people wondered whether the crisis had been predictable. The general consensus was that it had not. Even the most respected analysts had not anticipated this deepest of recessions.

But not enough: The climate summit in Copenhagen 2009, awaited with hope, failed. The industry complained of significant bottlenecks in the supply of raw materials. And the past waste management was not able to implement the announced paradigm shift from waste to resource management comprehensively and sustainably. Short-term economic aims and particular interests pushed the real problems and targets aside.

### 2.1 Waste? – No, just badly recycled raw materials

General Secretary Önnudóttir recalled that in 2006 the so called waste generated in the 27 member states of the European Union amounted to nearly 2.94 billion tonnes. For every EU resident this translates into a total amount of nearly 5,950 kg annually. Or to make it even clearer: in 2006 the European Union generated approx. 5,600 tonnes of waste per minute.

The repeatedly announced decoupling of waste generation from the gross value added occurred only with hesitation.

However, slowly it was recognized that many of the waste fractions have a high material or energy value and thus could contribute to resource, environment and climate protection. During the process of implementation of respective EU directives the share of separately collected waste fractions steadily increased, even if not always at the expected pace. The implementation of the recycling oriented EU directives was mainly driven by the increasing global demand and the developing market value for selected waste fractions, e.g. paper or steel.

Based on data from 2006, a 2009 analysis calculated for 17 selected waste streams with a high resource substitution potential showed that a total potential of 675 million

tonnes could be recovered as secondary materials by means of material or thermal recycling. This represented 23% of the total generated waste potential. In 2006, a total of 375 Mt of the analysed waste streams was material or energy (R1-procedure) recovered as secondary raw material. This volume amounted to merely 55% of the estimated total potential, while 45% remained unused, often with far-reaching consequences for the environment.

The recovery rates, however, differed between the individual waste streams as well as between the individual member states, which were at a different stage of waste management development.

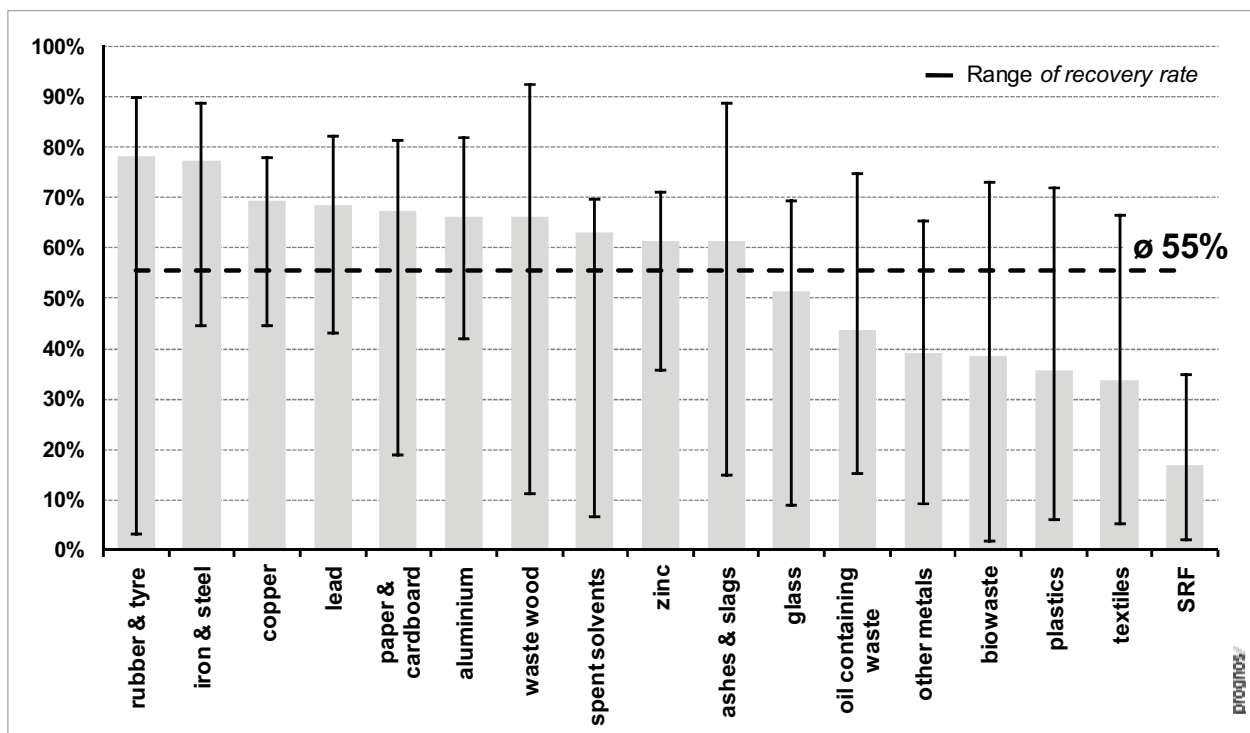

Note: The calculation is based on the in 2006 applied classification of incineration plants as disposal plants (D10 procedure). Taking into consideration that several incineration plants are able to achieve the energy efficiency criteria the share of mainly plastic waste recovered increases with the classification as waste-to-energy plant. In 2006, several countries have already classified incineration as recovery.

Figure 1 EU 27 average recycling rates for the analysed waste streams in 2006

In 2006, the highest (material and energy) recovery rates within the EU member states could be found for rubber & tyres with an average of 78%, iron & steel (77%), copper and lead (69% and 68%, respectively). Waste paper and cardboard could also be included in the group of secondary raw materials whose potential was recognized and used. The recovery rate amounted to 67% across the EU.

But it became also evident that information on many of the waste fractions - particularly for end-of-life-vehicles, batteries as well as electrical and electronic equipment - was not comprehensively collected and their resource potential therefore remained partly unknown and unused.

Electrical and electronic equipment, in particular, contains noble metals such as tantalum, lithium, or germanium, which various scientific studies at the beginning of the 21st century counted among the so called "critical" raw materials. The demand for these was growing worldwide. Their deposits and involved companies, however, were limited and partly situated in politically unstable regions. In addition, many experts estimated that deposits would dry up within a few years and called the attention to the risks of future supply.

Limited availability on the one hand and growing cost when accessing previously unused deposits on the other led to a real price increase. This particularly concerned raw materials whose limited availability could hamper the development and industrial use of future technologies. Tantalum, for example, was an important raw material for micro-capacitors and medical technology, germanium was used for optical technologies.

Significant deficits also existed in the area of biowaste. The EU recovery rate in 2006 was an average of only 39%. From country to country, the recovery rate ranged between 2% and 73% - these findings indicated already at the beginning of the millennium, that biowaste could help protect the climate as well as resources.

But it took another couple of years before a cascade utilisation of biowaste was implemented - that is the parallel production of renewable energy and the conservation of resources through preservation of nutrients and organic matter (fermentation, followed by further treatment [fertilizer, peat substitutes, compost, pellets]), added Mrs Ingibjörg Önnudóttir and continued in her historical review.

## **2.2 Contribution to CO<sub>2</sub> emission reduction**

At the beginning of the 21st century it was no longer disputed that waste is an important resource and that a sustainable waste (or better: resource) management could significantly contribute to climate protection. In several studies carried out by national and international organisations this became evident.

„We have a common responsibility and we could complement each other!“ This was the motto of a unique coalition of European waste management associations with quite different aims related to material or energy recovery, financing a Prognos-IFEU-INFU study to identify the resource savings and CO<sub>2</sub> reductions potential within the EU 27. The key aim of this study was to present first general results in time for the second



reading of the EU Waste Framework Directive in June 2008 – results, that would support and guide the decision-making process with essential detailed information and data.<sup>1</sup>

Even without remaining waste from households, in 2004 the use of the resource potential of 12 analysed waste streams in the EU 27 achieved CO<sub>2</sub> emission reductions of 206 Mt CO<sub>2</sub> equivalents. However, the high share of disposed remaining residual waste (responsible for 114 Mt CO<sub>2</sub> equivalents) has to be counted as a burden against these results.

Back then, experts developed several scenarios for Members of the EU Parliament calling on their willingness and capability to take decisions on waste management; decisions focussed on diverting from landfill and returning waste fractions as secondary raw material or energy to the production process.

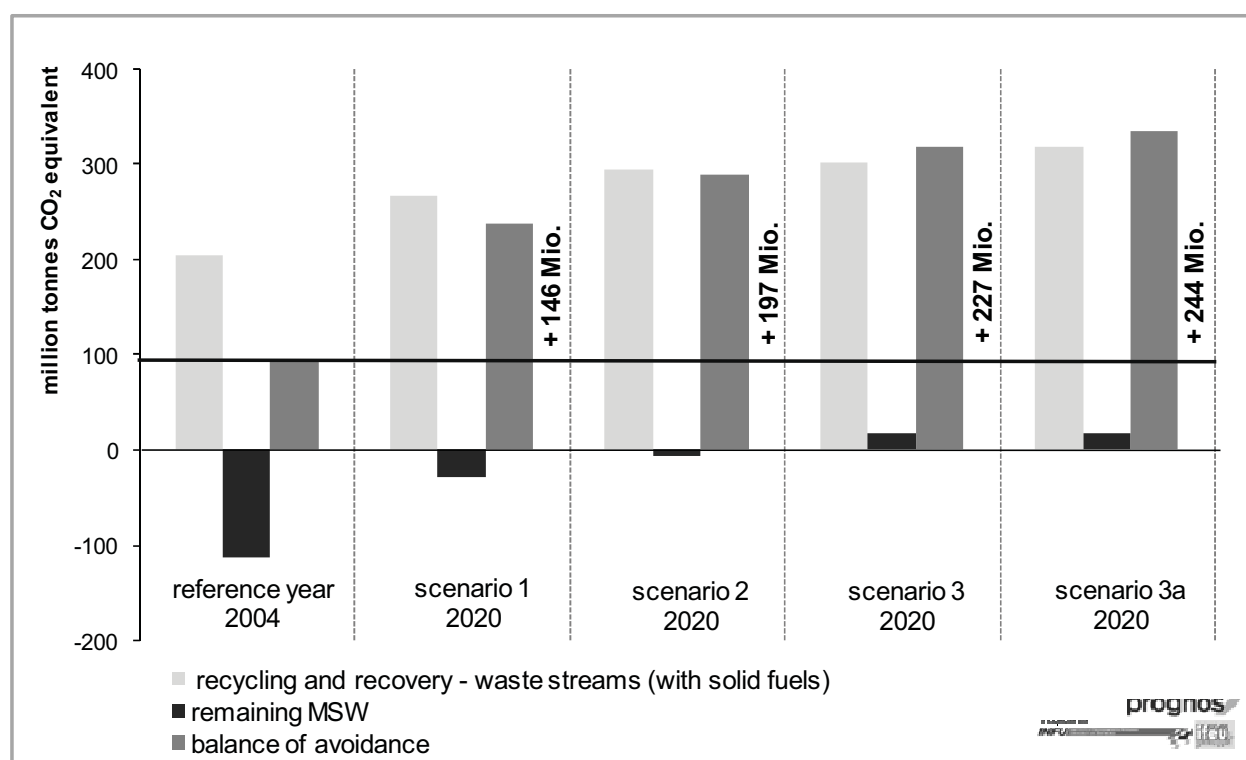

Note: negative data : CO<sub>2</sub> emission burden, positive data : CO<sub>2</sub> emission savings)

Figure 2 CO<sub>2</sub> balance for recycling/energy recovery of selected waste streams and remaining municipal waste

<sup>1</sup> Considered were the following waste streams, usable as secondary raw material by means of recycling or energy recovery and thus with a positive impact on resource and energy use: glass, paper & cardboard, plastics, iron & steel, aluminium, copper, waste wood, textiles, biowaste, rubber & tyres, mineral construction waste and secondary fuels.

Scenario 1 described the status quo of the development of waste management, limited to the implementation of the existing legal framework. Importantly, these experts confirmed that political decisions were going in the right direction. Through the achievable additional reduction of emissions by a minimum of 146 Mt CO<sub>2</sub> equivalents in 2020 (compared to 2004) waste management would contribute significantly to climate protection. The total savings corresponded to 19% of the European climate protection targets until 2020.

The experts further deducted that a significantly higher use of secondary resources – based on recovery targets for municipal solid waste (scenario 2: 50%, scenario 3-3a: 60%), construction and demolition waste (scenario 2: 70%, scenario 3-3a: 80%) and biodegradable waste (80%) as well as a strict ban on landfilling for biodegradable and high calorific waste would further increase the contribution waste management can make towards the EU climate protection targets to up to 31%.

### **2.3 From the Mind to the Heart**

The EU Waste Framework Directive adopted in 2008 set fixed recycling targets that were a positive signal to ban more of the so-called waste from landfills and improved the conceptual maturity. It was formally implemented in due time (December 2010) into national legislation by most of the member states, but not all. The willingness to continue in the right direction was there, but – according to Ingibjörg Önnudóttir in her historical review – not all opportunities were used.

Again waste was understood as waste. Conflicts of competence between material and energy recovery flamed up and led to compromises. There was a lack of sufficiently clear decisions, which would help to avoid disputes on interpretation. Only few of the member states dared to tackle further targets for the implementation process. Due to the principle of self sufficiency, more than once strictly confirmed, not all member states managed to achieve the Landfill Directive targets in time.

On the one hand, lack of funding for the construction of a sufficient number of waste treatment facilities caused the disposal of valuable secondary raw materials, on the other hand substantial financial resources were invested in the deconstruction of landfills to recover secondary raw materials that were previously disposed there and now urgently needed by the industry. The export-oriented European industry was faced with another problem: Many of the valuable secondary raw materials ended up in landfills in developing and emerging market countries where they were – in the best case – recovered and used by local industry.

The focus continued to be on the collection of “traditional” waste fractions like glass, light packaging and paper & cardboard. Also electrical and electronic equipment, batter-

ies or end-of-life vehicles were more and more centred. But other waste fractions remained in the shadow, their potential underutilized.

The need to advance waste management towards resource management was accepted in people's minds, but still had not arrived in their hearts.

But in 2020 the major challenges of the future could no longer be ignored.

## **2.4 Great Challenges of the Future**

Climate change had already become an irreversible part of life. Consistent efforts to prevent greenhouse gas emissions could only limit the extent of climate change to a degree tolerable for humans and nature. The orientation was given by the EU climate protection target - the 2° limit. Global warming had become a key driver of upcoming decisions in policy, economy, technology, and also waste management.

Globalization – merely interrupted by the financial and economic crisis at the end of the first decade – continued. However, for many years differences continued to exist between individual, mainly European, American and Asian countries in terms of their resource availability. The economic engine began to shift to then leading, mainly Asian, economies.

Globalization also affected the raw and secondary raw material markets, but did not automatically lead to better waste management. For many years to come, worldwide the most valuable resources were lost after single use, energy was wasted and all environmental media was burdened. An increasing level of industrialization was not automatically followed by a higher standard of waste management or better use of waste as a resource.

The demographic development also shaped the world significantly. In Germany the decline in population was tangible even in 2010, and the impacts became noticeable also in waste management. A significant reduction of waste volumes and plants with low utilization were only few results of the demographic development. A similar trend could be seen in most of the industrial countries in the following years.

On the other side, the population in developing countries grew, resulting in a global population growth. This, in turn, led to an increased use of raw materials (without water) and energy.

## **3 Change of Thinking**

And then came 2016.

Ingibjörg Önnudóttir fell silent. She did not need to speak any further. Everybody in the auditorium knew only too well what had happened ...

That the worst could be avoided was due to a European conference in the Czech town of Kroměříž in 2016.

Only a consistent change of thinking will rescue the future. The Indian economist CK Prahalad said, "The future is not an extrapolation of the past". With this in mind, representatives from industry, energy and waste management came together to intensely discuss present and future challenges and to develop the right measures. At the end of exhausting marathon negotiations, the conference agreed on a European Resource Directive. Finally the paradigm shift towards resource management within the framework of climate protection resource conservation and supply security prevailed. "Waste" became the taboo word of the year.

Many in the audience smiled. They could well remember that their mothers asked them to take out not the waste, but the resource bin. And many a little boy began to ask for an orange "resource car" for Christmas.

The decisions made in Kroměříž and their subsequent implementation was far reaching. The so-called life cycle approach that had been discussed for many years would finally be implemented.

The paradigm shift also reached the industry. The regulatory framework was so added by important practical initiatives, known e.g. from paper industry in the beginning of the 21<sup>st</sup> century. The industry committed to a voluntary product responsibility and accepted complete material responsibility. In the following years clear targets for resource-saving, material efficient product design and production technology were set and implemented. Products containing critical raw materials with strategic importance had to be labelled by the respective producer or trader. A voluntary product return concept insured that products containing raw materials with strategic importance could be distributed only with a guarantee of recovery at the end of the product life and re-use on a European level. The product return system was further supported by a scheme that would lease or rent (rather than sell) many products to the customer only for the period product use. The lease/rent-system was for the first time successfully used worldwide for mobile phones. This way, "real" material cycles were closed.

Apart from the further improvement and correct and complete implementation of legal framework conditions and regulations it was also necessary to create a relevant infrastructure for a sustainable resource management.

Funding, however, was scarce. And while previously some countries did not have sufficient financial resources to establish necessary recovery capacities, other countries saw costly plants stand idle due to under-utilization.

Finally, the pilot project of a resource park in the Polish – German - Czech triangle – co-financed by the European Regional Development Fund (ERDF) between 2014 and 2017 – was the breakthrough away from national self-sufficiency towards regional cross-border concepts.

To obtain the necessary funding a scheduled deconstruction of an existing landfill in Saxony, Germany, was assigned less priority and postponed. As a result of a mutual dialogue, everyone involved agreed, that it is not sensible to, on the one hand, invest in the deconstruction of a landfill holding secondary raw materials, when, at the same time and in the immediate vicinity secondary raw material potential remains unused or scarcely tapped.

Important raw materials could thus be returned to the material cycle. At the same time the energy supply for existing and new industry in the region was secured.

The concept proved that regions that are environmentally and economically effective must not end at otherwise open borders. In the following years the concept behind this pilot project was further improved and successfully implemented in other European regions. Implementation was particularly successful when protagonists were able to put aside their own particular interests and competence conflicts for the sake of linking economic cycles and coordinating their actions.

It became evident, however, that such a scheme that focuses only on the European member states soon reaches its limits.

That is why in 2020 the world witnessed the establishment of the International Energy and Resource Organisation (IERO). The IERO successfully assisted in the re-organization of global economic relations on the basis of consistent and systematic resource savings to expedite climate protection, conservation of resources and security of supply.

Shortly afterwards, the “certificate scheme” that was introduced worldwide made it possible to pay compensation rather than recover raw materials back in their country of product origin, thereby avoiding needless transport. The international “certificate scheme” also prevented that the rules protecting raw materials would be used to establish protectionist markets. At the same time it was possible to avoid an ecologically unnecessary return of raw materials to their country of origin while ensuring the general recyclability and re-usability of critical raw materials worldwide.

The General Secretary of the IERO, Ms. Ingibjörg Önnudóttir ended her commemorative speech with the following words of appreciation:

“The generation of the early 21<sup>st</sup> century identified with the responsibility it inherited and distinguished themselves with personal commitment, sense of duty, readiness, reliability and personal initiative, going far beyond what might be expected. It quickly adapted to new challenges and combined excellent analytical-conceptual thinking with practical and operational solutions, implemented with great determination. With its motivated work and team-oriented culture this generation contributed in creating a global resource management system.”

Is this only a dream?

What will our grandchildren and great-grandchildren say about us? That we might have tried to do our best ... but sadly it was not enough?

It is in our hands to shape history. Let us act – **NOW!**

## 4 Literature

- |                        |      |   |
|------------------------|------|---|
| Prognos – INFU – IFEU  | 2008 | Resource savings and CO <sub>2</sub> reduction potential in waste management in Europe and the possible contribution to the CO <sub>2</sub> reduction target in 2020, Berlin      |
| Prognos AG             | 2009 | Europäischer Sekundärrohstoffatlas 2006 Status Quo und Potenziale – Edition 2009 / European Atlas of Secondary Raw Material 2006 Status Quo and Potential – Edition 2009, Berlin. |
| Böllhoff/Barth (Hrsg.) | 2009 | Der Zukunft auf der Spur, Analysen und Prognosen für Wirtschaft und Gesellschaft, Schäfer-Poeschel Verlag, Stuttgart, ISBN 978-3-7910-2918-4.                                     |

### Author's address(es)

Dr. Bärbel Birnstengel – Holger Alwast – Arno Häusler

Prognos AG

Goethestrasse 85

D-10623 Berlin

Phone +49 30 52 00 59 215

Email baerbel.birnstengel (at) prognos (dot) com

holger.alwast (at) prognos (dot) com



arno.haeusler (at) prognos (dot) com

Website: [www.prognos.com](http://www.prognos.com)

# **The new waste framework directive and next steps in EU waste policy**

**Andreas Versmann**

European Commission – DG Environment



## **The Waste Framework Directive 2008/98/EC in the context of EU waste policies**

**Andreas Versmann**

**European Commission – DG Environment**



**Cologne – June 2010**



## Results of more than 30 years of European waste policy

- waste treatment facilities under control of environmental authorities
- waste disposal is subject to environmental standards
- disposal of hazardous waste monitored
- shipment of waste monitored
- good implementation of waste legislation?
- recycling and recovery of waste sufficient?
- waste prevention?



## Generation of municipal waste 1995 to 2007

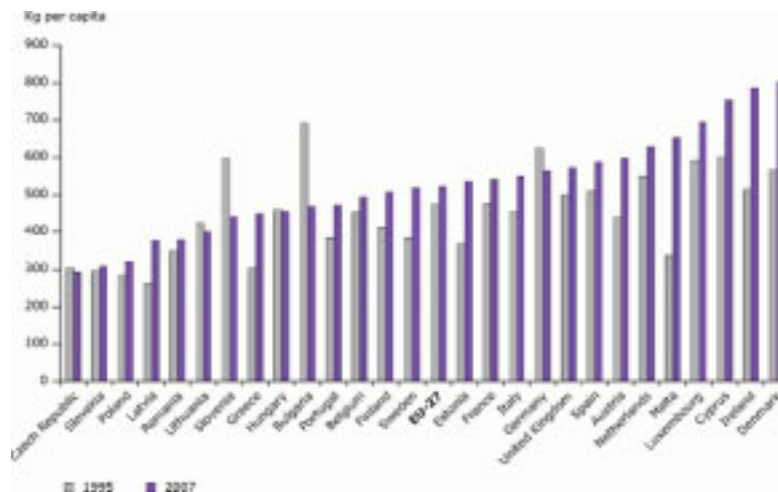

## Recycling, incineration and landfilling of municipal solid wastes in Europe

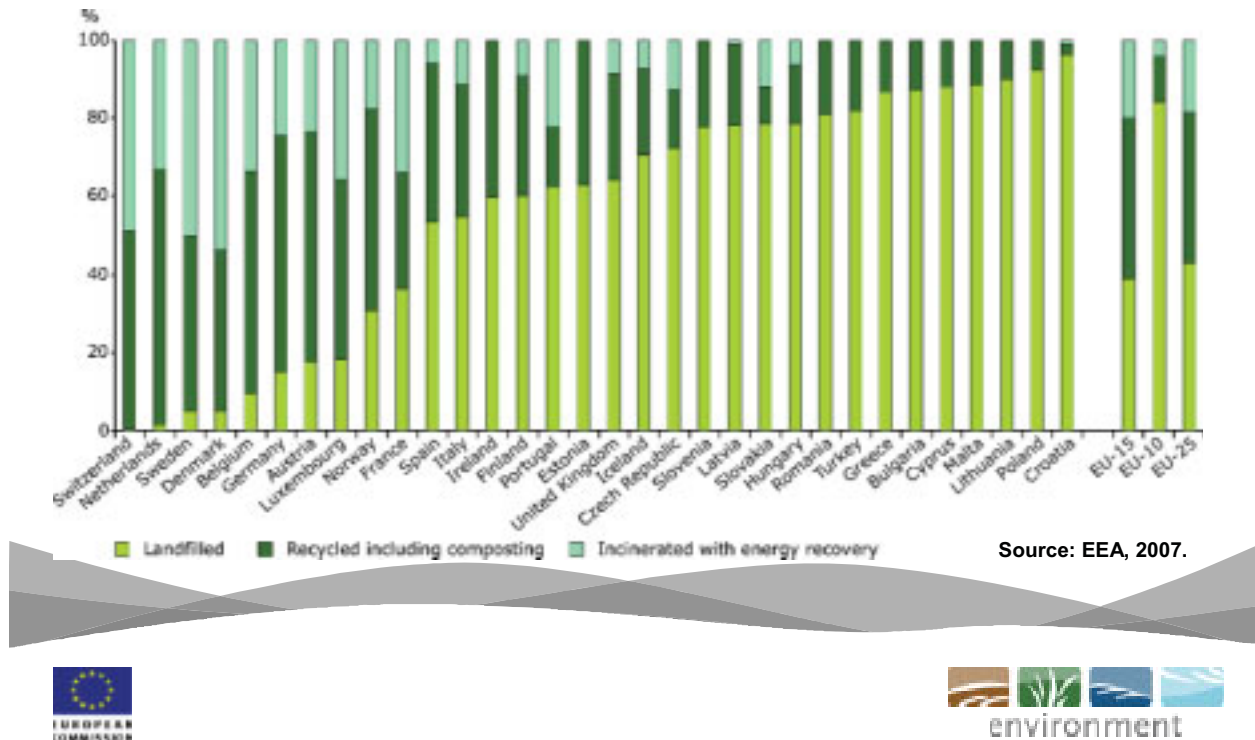

## Objectives of European waste policy

- decoupling economic growth from environmental impacts
- prevention of waste
- moving towards a recycling society
- promoting the use of waste to produce energy
- better implementation of waste legislation

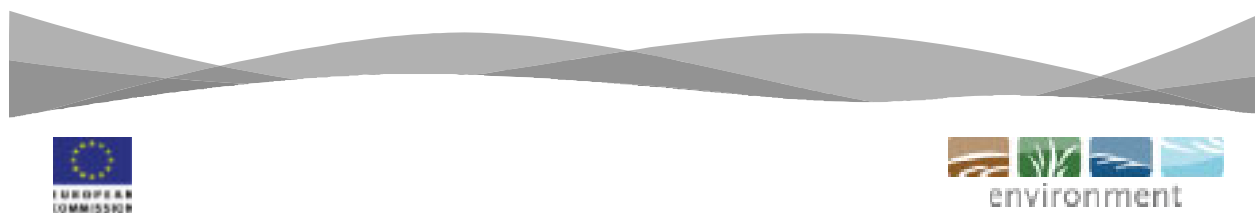



## Meeting these objectives with the new Waste Framework Directive 2008/98/EC



### The 5-step Waste Hierarchy

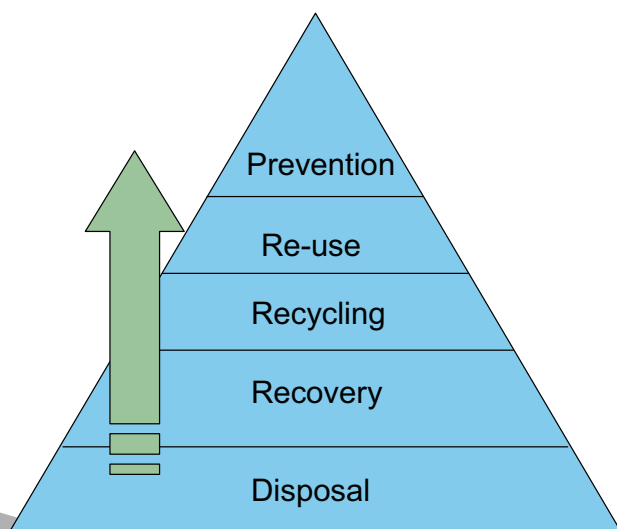

- Order of priorities
- Best environmental outcome
- Life-cycle approach

European Platform on Life Cycle  
Assessment  
Life Cycle guidance for waste  
management

<http://lct.jrc.ec.europa.eu/waste>



## Waste prevention – a new dimension

- **Member States to establish waste prevention programmes until 2013**
  - set out prevention objectives,
  - determine qualitative and quantitative benchmarks or targets for waste prevention,
  - describe prevention measures, such as
    - Economic instruments for sustainable resource use
    - Promotion of eco-design for products
    - Campaigns to change consumer behaviour
    - Supporting the reduction of industrial waste (EMAS, ISO 14001)
    - Green public procurement

### ■ **Breaking the link between economic growth and waste generation**



## Waste prevention: framework to be further developed

- **European Commission**
  - Establishment of a system for sharing information on best practice regarding waste prevention
  - Development of prevention guidelines for Member States
  - Development of waste prevention indicators
- **2011: Commission report on the evolution of waste generation and waste prevention**
- **2014: Commission to propose waste prevention and decoupling objectives by 2020, if appropriate**



## Promoting recycling by setting targets

- **targets in Art 11(2) WFD to be achieved by 2020**
  - ➔ preparation for re-use, recycling of materials “*such as at least*” **paper, metal, plastic, glass from households** + option for **similar wastes** to be increased to “*a minimum of overall*” **50%**
  - ➔ preparation for re-use, recycling and backfilling of **70% construction & demolition waste**
  
- **Commission decision on calculation methods**
  
- **reports of Member States every 3 years together with the regular implementation reports**
  
- **Commission review of the targets in 2014**



### Member States options to calculate the 50% target

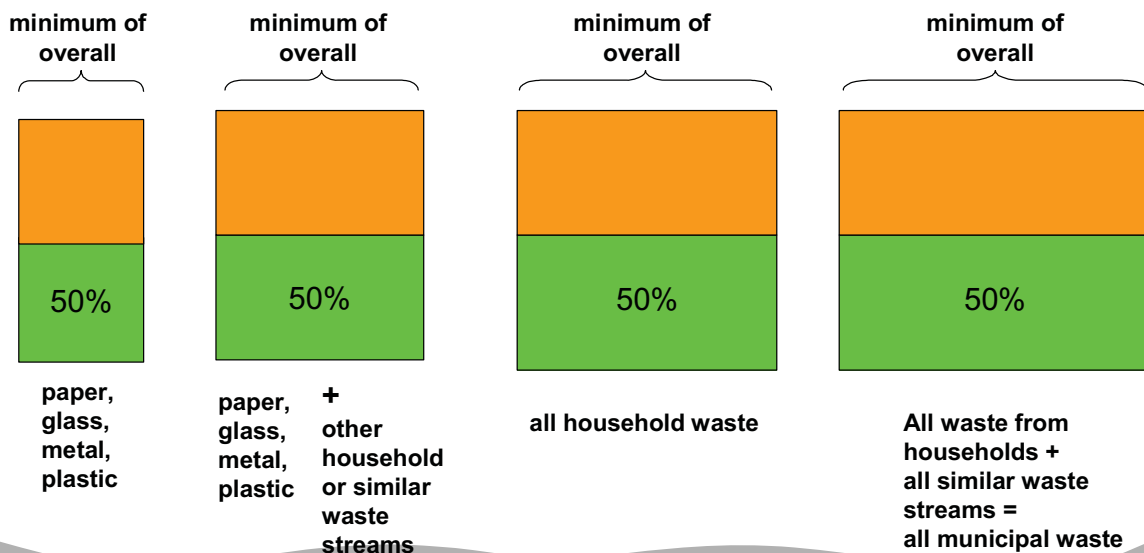



## Separate collection of waste

### ■ Waste Framework Directive

- separate collection at least of paper, metal, plastic, glass by 2015
- separate collection of bio-waste (composting and digestion)
- separate collection of waste oils
- ban on mixing of hazardous waste

### ■ Other waste legislation

- batteries and accumulators
- waste from electrical and electronic equipment
- packaging waste
- waste containing PCB/PCT



## Recycling and recovery of bio-waste

### ■ Art 22 WFD: Member States shall promote

- Separate collection of bio-waste
- Recovery of bio-waste

### ■ Commission is currently finalising an impact assessment

### ■ Do we need more specific European legislation on bio-waste?

- Separate collection?
- Recovery/recycling targets?
- Quality standards for composts?

### ■ 2010: proposals, if appropriate



## Supporting recycling markets by setting end-of-waste criteria

- **End-of-waste criteria should**
  - support recycling markets and
  - improve the implementation of waste management law
  
- **Commission is currently working on**
  - iron and steel scrap
  - aluminium scrap
  - copper scrap
  - paper
  - glass

### ■ Member States and stakeholders in JRC working groups



## How could end-of-waste criteria look like? Example iron and steel scrap

- **Product quality**
  - Compliance with European Steel Scrap Specification or customer specification
  - Steriles  $\leq 2\%$
  - Free of visible oil
  - Free of radioactivity
  - No hazardous properties (WFD Annex III)
- **Input material/treatment**
  - Waste with hazardous compounds to be de-polluted (cars, WEEE)
- **Quality management**



## Promoting waste-to-energy

- **energy-efficiency-formula in Annex II as part of the recovery definition:**
  - scope: Incinerators for municipal solid waste
  - waste replacing fuels in the plant or in the wider economy
  - 0,60 energy efficiency for installations in operation before 2009
  - 0,65 energy efficiency for new installations
  
- **incentive to improve energy-use from waste incineration**
  
- **Commissions intends to prepare guidelines together with an expert working group**
  
- **Risk of additional waste shipments:**
  - Extension of proximity principle to recovery of mixed household waste



### SOME TARGETS IN EU WASTE LEGISLATION

		min recovery	min recycling	collection rate
<b>Packaging</b>	<b>2008</b>	60%	55%	
<b>Cars</b>	<b>2015</b>	95%	85%	100%
<b>Electronics</b>	<b>2006</b>	70%	50%	min 4 kg per inhabitant per year
<b>Batteries</b>	<b>2011</b>		50% to 75% (efficiency)	
	<b>2012</b>			25%
	<b>2016</b>			45%
<b>Tyres</b>	<b>2006</b>	0 landfill of tyres		
<b>Biowaste diverted from landfills</b>	<b>2006</b>	reduction to 75% of the 1995 level		
	<b>2009</b>	reduction to 50% of the 1995 level		
	<b>2016</b>	reduction to 35% of the 1995 level		
<b>New targets</b>	<b>2015</b>	Separate collection: at least paper/metal/plastic/glass		
<b>(WFD)</b>	<b>2020</b>	50% household waste		
	<b>2020</b>	70% construction and demolition waste		

## Waste Hierarchy - the future!

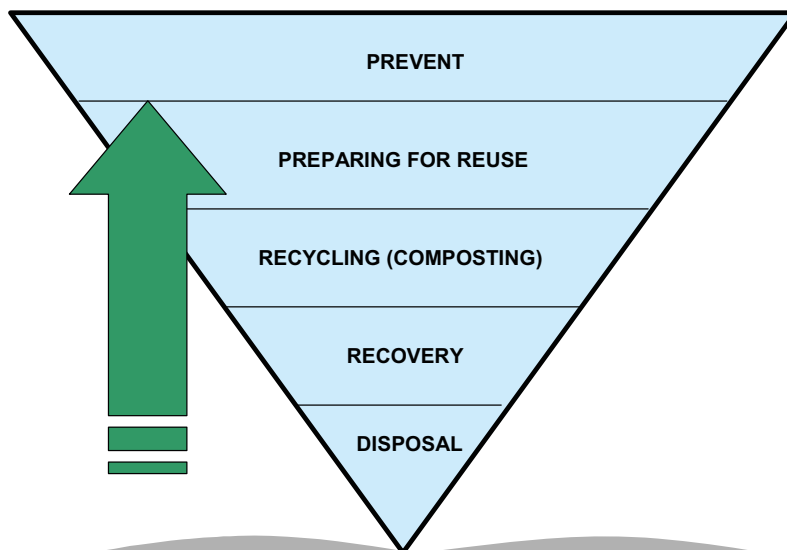

**Integrating waste policies  
into the policy on  
sustainable production  
and consumption**



## Focus on environmental impacts of products

- 70-80 % of environmental impacts by products & services
  - food & drink
  - housing (buildings, use, equipment)
  - transport
- Waste policy to be integrated into policy on sustainable production and consumption
- Commission action plan 2008 on sustainable production and consumption



## Measures to improve the sustainability of production and consumption

- **Improve the eco-design of products**
  - Ecodesign-Directive, Ecolabel: extension from energy efficiency to resource efficiency?
  - Recyclability and recycled content?
- **Increase green public procurement**
  - Increase to 50% by 2010
- **Greening the supply chain**
  - Commission's retailer forum
- **Supporting recycling markets on the demand side**



## On the horizon ...

- **2010: Review of Commission's waste and resource strategies**
- **2011: report on waste generation and prevention**
- **2014:**
  - ➔ review of the targets of the Waste Framework Directive
  - ➔ Report on waste prevention and decoupling objectives for 2014



**ONLY ONE EARTH**



**European Commission**

[andreas.versmann@ec.europa.eu](mailto:andreas.versmann@ec.europa.eu)



<http://ec.europa.eu/environment/>





# Current situation and implementation of the waste framework directive in Germany

Dr. Andreas Jaron

Ministry of Environment, Bonn, Germany

## 1 Current situation of Waste Management in Germany

The current situation of waste management in Germany has technical, economic and legal aspects. Technically and organisationally Germany has reached a high standard in waste management including environmentally sound capacity for almost all kinds of wastes. This is reflected in the evolution of imports and exports esp. in hazardous wastes.

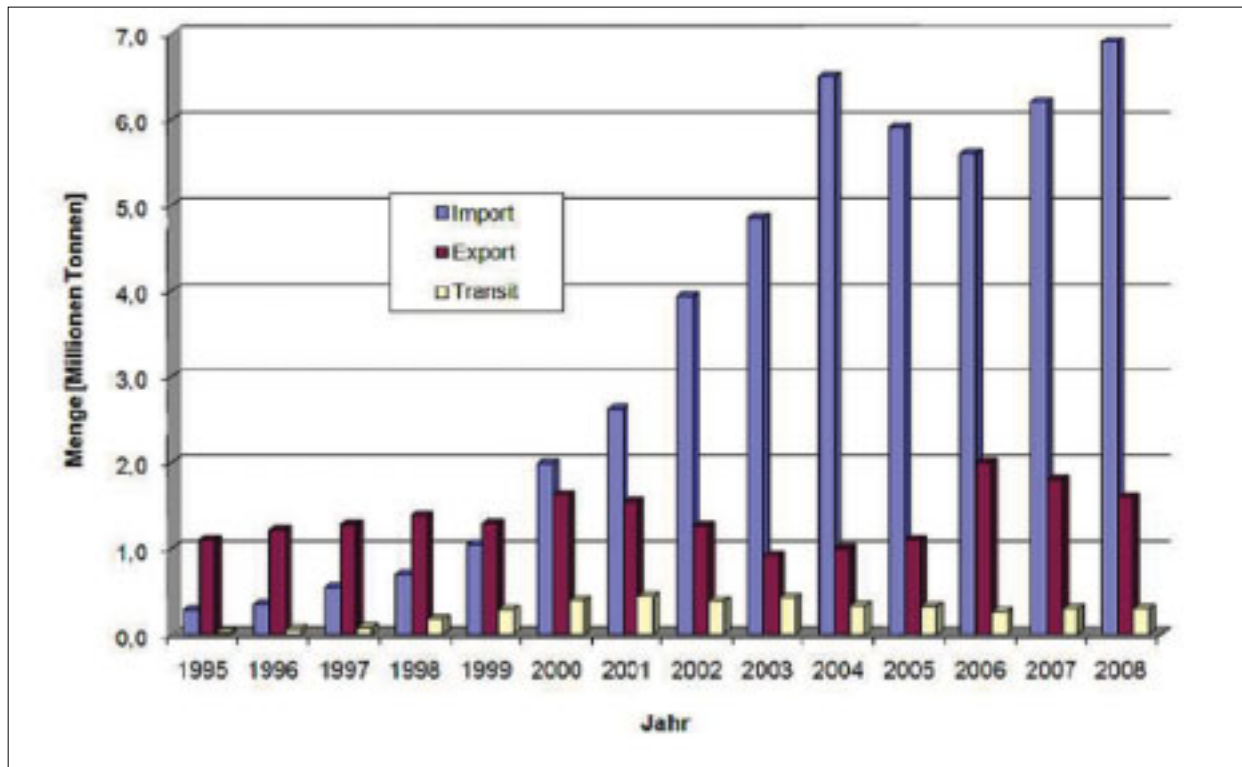

Figure 1 Import, Export and Transit of hazardous waste

The economic situation is currently effected by the global economic crisis, but the trend to return resources and energy from waste to the economic cycle is still positive. The legal discussion is mainly about the revision of the Circular Economy Act to transpose the Waste Framework Directive into national legislation; connected to this is the question of private and public responsibility for the waste management.

The latest data on waste management describe the situation in the waste management sector in 2007. The data come from the Federal Statistical Office, the Federal Environment Agency and other sources. The data show that waste management in Germany has continued its positive development with regard to environmental protection - a trend reflected in practically all the figures. In economic terms too, there are encouraging findings behind these developments: investments, employment and turnover in the waste management sector still have potential for growth.

A particularly positive aspect is the role of waste management in resource conservation and climate protection: recycling and other recovery procedures have significantly increased the share of recoverable material in the materials cycle. For example, in 2007 around 62% of household waste was recycled - in 1990 it was just 13%. Recovery rates of other waste types have also increased considerably in recent years. It is equally evident that a modern waste management industry contributes substantially to climate protection by harnessing the energy in waste and avoiding climate gases from landfills.

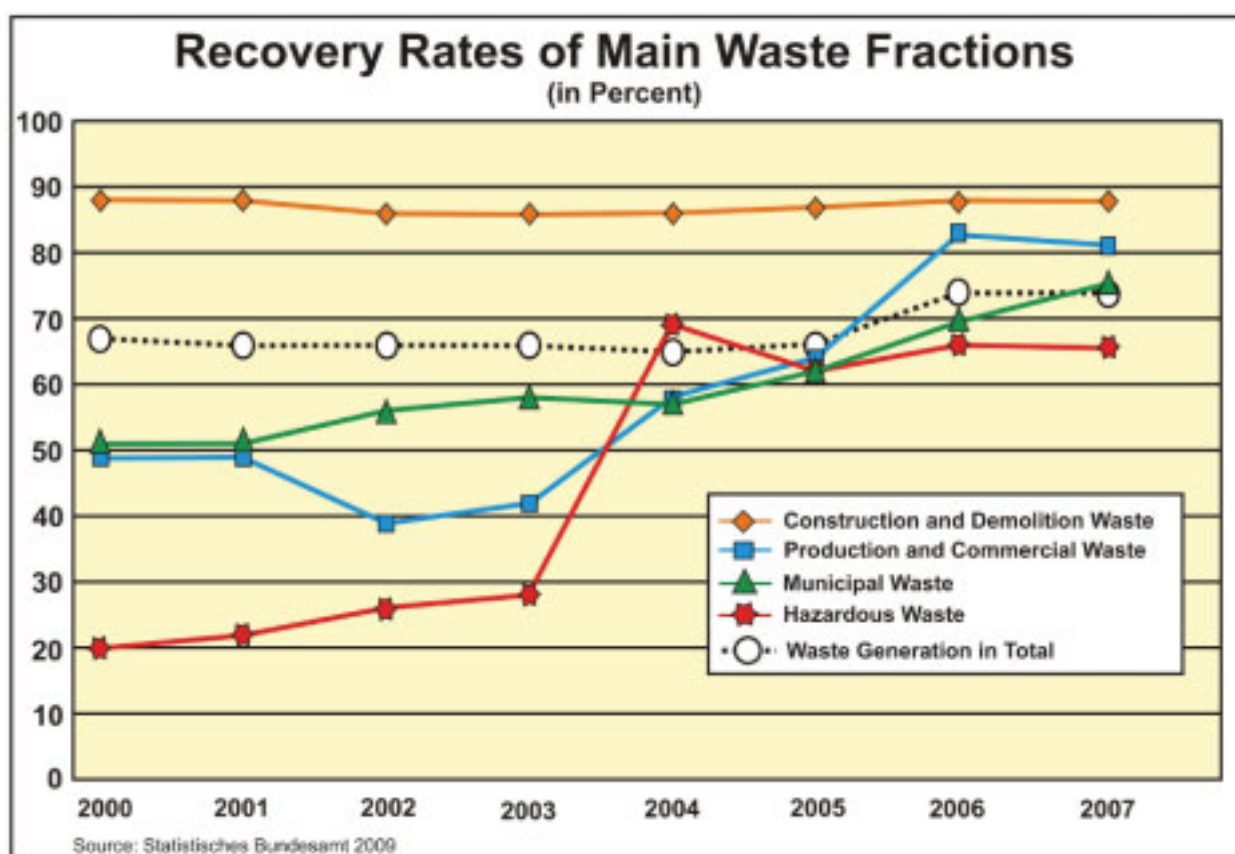

Figure 2 Recovery Rates of Main Waste Fractions

Positive developments can even be seen in the field of waste prevention, which will become a key issue over the next few years due to the provisions of the amended Council Directive on Waste: there is a decline in both waste intensity - i.e. the volume of waste per inhabitant – and waste generation in relation to economic growth

(decoupling). Statistically unclear until now are the effects of the global economic and financial crisis in 2008 and 2009 in respect to these trends.

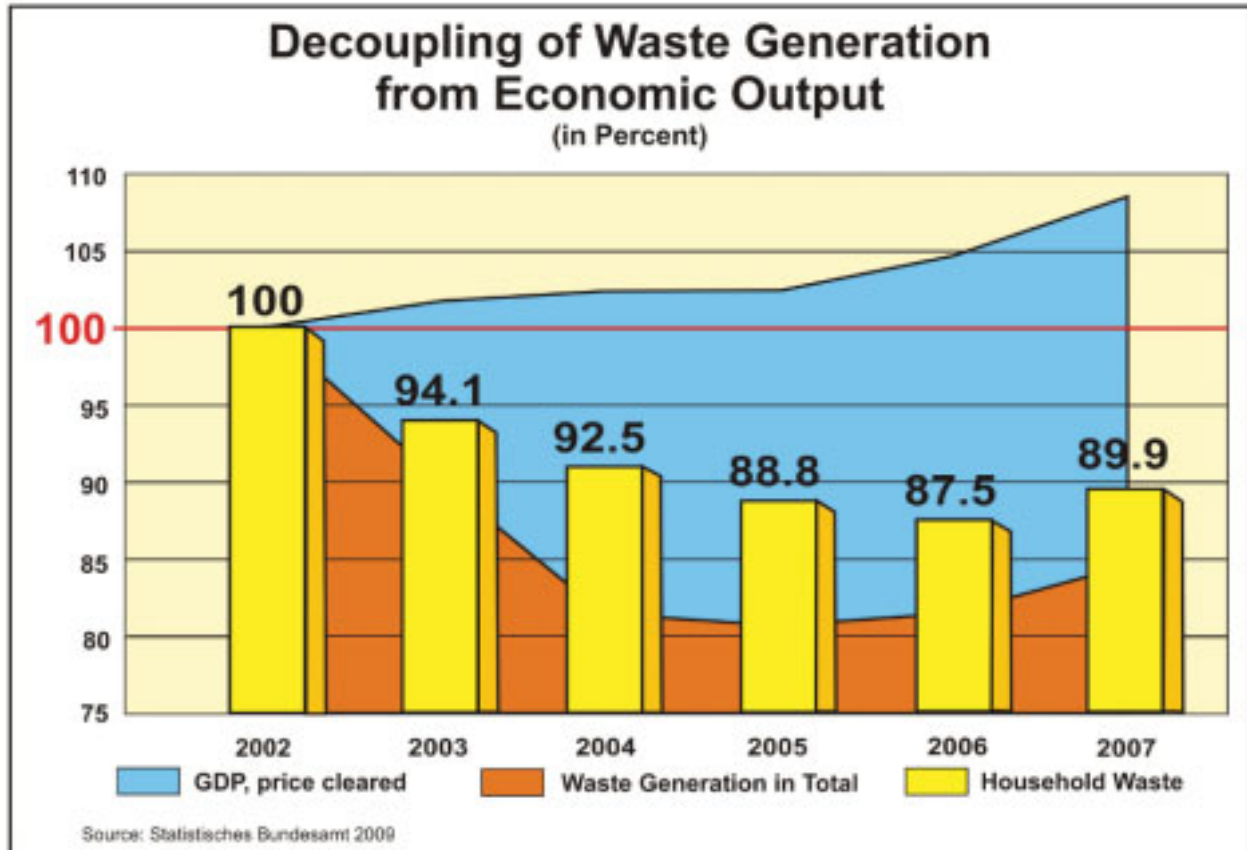

Figure 3 Decoupling of Waste Generation from Economic Output

Besides the global objectives of environmental policy with regard to resources and climate, the data also describe the original tasks of the waste industry with regard to the protection of human health through the prevention of infection, and the conservation of environmental media through air, water and soil protection: thus the number of landfills is steadily falling while recirculation of nutrients and soil improvers from bio-wastes is constantly increasing.

Nevertheless, too many valuable materials are still being lost because of inadequate waste management - waste electrical appliances, end-of-life vehicles, bio-wastes and plastics are just some examples of areas where further global action is needed. To a great extent rare metals, which are irreplaceable for modern technology, are lost after consumption. These strategic resources will shortly be the focus of the waste and resource management sector. In Germany too, which is considered a model in the field of waste management, there is still potential for considerable improvements in efficiency.

Economically we face a concentration process in the waste management sector accompanied by the call of the private sector to privatize mayor parts of the public

waste management infrastructure. The resistance of the public sector concerning economic services of general interests, which are left to the definition of national legislation by the EU-legislation, is mainly based on the perception, that security of environmentally sound waste management esp. in the municipal sectors (including littering, road cleaning, etc.) can only be assured by a strong role of the public sector in this field.

On the other hand more than 60 percent of the municipal waste collection and management are carried out by private companies by order of municipalities. The relationship between private and public sector in the field of waste management is approved for long and does need in relation to effectiveness and security probably just adjustments and clarifications. Mayor changes just in benefit of the private sector seem to be problematic.

## **2 Waste Framework Directive**

The intensive revision of the Council Directive on Waste, the so called Waste Framework Directive (WFD) has been in progress for many years. In December 2008 finally it came into force. Before that agreement was reached in the second reading of the European Parliament through a legislative resolution. The revision of the WFD towards a modern and sustainable waste policy had already been decided through political agreement in the first reading under the German EU Presidency in 2007.

Already in 1999 the EU-member states started a process of five workshops (until 2004) with the Commission to identify the practical and legal problems connected to the WFD. A lot of possible solutions were discussed and elaborated during these workshops (in Aachen, Mechelen, Rotterdam, Vienna and Leipzig) which found their way into the revised WFD. The proposal of the Commission of December 2005 included most of these workshop's results, others were included during the legislative process.

The most important issues negotiated in the Council were:

- the scope of the Directive (in particular the exclusion of immovable objects)
- criteria for determining by-products and the cessation of waste status
- definition of the term "recovery"
- distinction between recovery and disposal, in particular with respect to waste incineration plants
- the principle of self-sufficiency and proximity for mixed household waste and waste destined for incineration

- waste hierarchy and how it will be applied
- provisions on waste oil, hazardous waste and bio-waste
- waste management plans and waste prevention programs.

At the end of its EU Presidency Germany successfully concluded the negotiations in the Environment Council on the first reading of the Council Directive on Waste with a political agreement. Twenty-seven Member States agreed on common principles of waste management policy in a highly complex and far-reaching legal matter. After additions to the recitals and a legal review of the wording, the Council adopted the Common Position on 20 December 2007. Decisions on the proposals to amend the Commission draft had already been taken in the European Parliament on 13 February 2007. The European Parliament's proposals were in part incorporated by the Council.

In February 2008 the European Parliament started the second reading of the revised Council Directive on waste. The Rapporteur of the European Parliament, Ms Jackson, presented her [recommendations for the second reading](#) on 5 February 2008, accepting the overall concept and a large number of the core elements of the Council's Common Position. In its legislative resolution of 17 June 2008 the European Parliament adhered closely to these recommendations. However, problematic additions and tightening of provisions (such as linking the term of recovery to ecological requirements which would lead to irresolvable legal problems in practice) were not included. In the light of the formerly opposing position of the EP during the first reading, this must be considered as a major success for the Council.

The following details should be mentioned:

- exclusion of immovable objects from the scope of the Directive (waste law therefore restricted to movable objects)
- provisions on definition of by-products
- cessation of waste status
- producer responsibility
- distinction between recovery and disposal in waste incineration plants based on energy efficiency formula
- ensuring self-sufficiency in the disposal of household waste, provision to protect against imports
- provisions on bio-waste

- concept for authorisation and notification requirements
- tasks assigned to Commission under comitology rules

The main changes introduced by the European Parliament during the second reading concern waste disposal and recovery. In addition to a mandate for the Commission to develop further instruments of waste prevention, recycling quotas for certain waste flows and guidelines for several articles were included in the directive.

The new directive (Directive 2008/98/EC of the European Parliament and of the Council of 19 November 2008 on waste and repealing certain Directives) strengthens waste prevention, the key objective of modern waste policy, through new instruments such as producer responsibility and waste prevention programs. It also supports the recovery of waste by introducing obligations to separate waste and recycling quotas for certain types of waste. Furthermore, it defines the term waste more clearly, which ensures legal certainty and improves the acceptance of quality recycling products. It also clarifies the long debated distinction between energy recovery and disposal of waste by introducing a more specific definition and energy efficiency criteria. All these measures will go into the direction of saving resources and protecting the climate. At the same time the directive will protect national waste incineration infrastructure from being overburdened.

### **3 Implementation of the WFD into German Legislation – Revision of the Circular Economy and Waste Management Act (Kreislaufwirtschafts- und Abfallgesetz)**

The revision of the German waste act in the first line is necessary to transpose and implement the WFD. Article 40 of the WFD gives member states time until 12th of December 2010 to do this transposition. Additionally a development and modernisation of the German waste management regulations is foreseen. The principal approach of the revision process is to keep the established structures and approved rules of the current Circular Economy and Waste Management Act and to transpose the requirements of the WFD in a new Circular Economy Act (the term ‘waste management’ in the title of the act is proposed to be deleted due to the development into a resource related act). Most of the requirements are foreseen to be transposed unmodified in substance.

Main elements of the published working paper for discussion are:

- New terminology (waste definition, by-products, end-of-waste property, recovery, recycling, disposal)
- Introduction of the new five-step waste management hierarchy



- 
- Legal basis for Waste Prevention Programs
  - Introduction of recycling quota for municipal waste (65% instead 50% in WFD) and for C&D-waste (80% instead of 70% in WFD) from 2020 on
  - Introduction of an area-wide separate collection of bio-waste (from 2015 on)
  - Legal basis for the introduction of a recycling bin (collective collection of packaging and similar non-packaging wastes)
  - Safeguarding of the “dual responsibility” of private and public waste management
  - Debureaucratisation
  - Improvement of the qualification of waste management enterprises

The working paper is a basis for the discussion with stakeholders. It's not the agreed position of the Federal Government. Next steps will be the agreement process in the Federal Government and the legislative process through EU-notification, Parliament and Federal Council (second chamber representing the Federal States).

In addition several other works have to be done:

The elaboration of the Waste Prevention Program needs a substantial and comprehensive analysis of the existing and possible measures available to the public sector. In a first step we study (Wuppertal Institute and Öko-Institute) the existing knowledge about waste prevention measures, in a next step benchmarks and possible indicators will be used to evaluate the found measures in relation to their environmental impacts and benefits. Finally a political evaluation has to take place taking into account the economic and social implications of different environmentally beneficial measures.

On EU-level the

- guidelines on the interpretation and practical use of the Energy-recovery-definition in Annex 2 operation R1,
- calculation methods of recycling quotas for household waste and C&D-waste, and
- End-of-Waste criteria for special waste streams becoming Commission Decisions following the procedure laid down in Article 39 of the new WFD

are under elaboration.

# From waste to materials management

John Wante

OVAM, Mechelen, Flemish Region, Belgium

## Abstract

The transposition of the Waste Framework Directive offers the opportunity to thoroughly rethink the Flemish waste legislation and transform it into a legal framework that will accommodate recent and future foreseeable evolutions in waste management. Waste management practices are no longer solely focused on reducing the environmental impact of waste generation and treatment. Waste management is more and more placed in a broader perspective where the focus is widened to lowering the environmental impact over the whole life cycle of products. The central policy question has become how to use raw materials and products derived from them as efficiently as possible. This article describes how Flemish waste legislation will be reframed to address this more complex issue.

## Keywords

Waste, materials, sustainable materials management, waste framework directive, waste legislation, materials legislation, lifecycle thinking, resource efficiency, recycling

## 1 The need for redrafting existing waste legislation

### 1.1 The new waste framework directive

The waste framework directive forms the legal basis of European waste legislation. The original directive dates from 1975 and was thoroughly revised in 2008. This revision served several purposes. First of all, the revision was part of the process of “better regulation” in which existing environmental legislation is screened on potential simplification without lowering the level of environmental protection. The new waste framework directive integrates three old directives, namely the old waste framework directive, the directive on hazardous waste and the waste oil directive, three pieces of legislation that showed considerable overlaps. The new directive clarifies frequently used concepts in waste policy, such as recovery and disposal and, importantly, the distinction between a waste and a non waste. It also tries to define what needs to be treated under waste legislation and what not.

Secondly, the waste framework directive translates the objectives of the thematic strategy on waste prevention and recycling into legal terms. We need to evolve towards a “recycling society”. Hence, the directive contains more provisions to stimulate the separate collection of waste and its recycling. The waste hierarchy consisting of five steps

(prevention, preparation for reuse, recycling, other recovery and finally disposal) has been turned into a legal requirement for all Member States. The concept of “life cycle thinking” is introduced: Member States need to set up their policies in such a way that the best environmental outcome is obtained taken from a life cycle perspective. This may require a deviation from the waste hierarchy, where underpinned with environmental, economic and social considerations. The focus is clearly on reducing the environmental impact of waste generation and treatment and not solely on quantities of waste. In line with the waste strategy, the directive pays more attention to prevention measures so as to contribute to more resource efficiency and decouple environmental impact from economic growth.

Thirdly, the new waste framework directive tries to contribute to leveling the playing field. For instance, the directive contains a provision that enables the European Union to lay down harmonised standards for marking the “end of waste” for specific waste streams, as a response to a wide range of different requirements and criteria that have been laid down by different competent authorities throughout the EU for several waste streams since the past twenty years. The directive also clarifies under what conditions a municipal waste incinerator is to be classified as “recovery” in an attempt to avoid a wide range of different interpretations in the EU. There is also an article on harmonised standards for waste treatment installations that need to be fulfilled as a minimum so as to allow a free movement of waste in the EU between those installations that fulfil the minimum standards.

These are all elements that have urged the Flemish legislator to thoroughly revise existing waste legislation.

## **1.2 The shift from waste to materials management**

In the eighties a lot of attention was given to cleaning up numerous illegal landfills in Flanders. The generation of waste and its treatment was primarily seen as a source of potential damage to air, ground water and soil in the immediate vicinity of treatment facilities. The incineration of waste was hardly seen as a solution because it was perceived as shifting environmental problems from one compartment (water, soil and use of scarce open space) to another compartment (air). Limiting the need for landfills and incinerators was the main driver of Flemish waste policy.

In the nineties all attention went to setting up separate collection schemes so as to step up recycling. Almost all municipalities introduced household waste charging. An extensive network of civic amenity sites and reuse centres was set up. This policy proved very successful. In five years time the amount of household waste that was separately collected for recycling rose from less than 20 % to around 50 % and some years later to

even more than 70 %. The Flemish became champions in separating their waste and recycling it. However, during the same time the amount of waste generated rose from 400 kg per person to more than 550 kg. A new issue needed attention: how to prevent the generation of waste and its associated environmental impact? Waste prevention measures were implemented, mainly based on communication and subsidies for waste prevention initiatives. During the nineties we also noticed a shift in responsibilities. Extended producer responsibility schemes came to existence in which the producer or distributor of the product that becomes a waste is held (partly) responsible for its collection and recycling.

Thanks to high standards for landfilling, incineration and recycling, the direct threat of waste generation and treatment to local environmental quality has seriously decreased. Since 2000, the environmental impact of waste management is more and more linked with other, more global environmental problems: climate change, loss of biodiversity and growing scarcity of resources. Waste is seen as a symptom of unsustainable production and consumption patterns. We have started to realize that materials in general (be it raw materials or products derived thereof or waste) need to be managed more efficiently if we want to avoid irreversibly depleting the earth's natural capital. It is this broader policy, managing materials over their complete life cycle that is named "materials management". This more holistic approach tries to overcome the disadvantages of scattered environmental policies that focus on isolated aspects such as clean air, water, soil, less greenhouse gases or less waste. A materials management approach that is overseeing the whole life cycle is less likely to shift impacts from one environmental compartment to the other and more likely to set the right priorities.

Flemish waste legislation was focused on the environmentally sound management of waste. The new waste legislation (the Decree on sustainable management of material cycles and waste, shortly called materials decree) will have a broader scope so as to accommodate a "sustainable materials management" approach.

## **2 Content of the new materials decree**

### **2.1 A new set of definitions**

The materials decree contains some new definitions that are essential for a good understanding of a materials policy. The first definition is that for "material". A "material" is defined as any substance that is mined, recovered, harvested, produced, distributed, used or discarded or any object that is derived thereof. This definition is very broad and covers actually any tangible physical substance or object that is used in our economy. It does not cover unexploited resources (such as fish in the ocean), but it does cover any-

thing that is taken from resources until it is returned to nature in some form or another. There is also a definition for a “material cycle”. This is the whole of consecutive actions between the moment a material is taken from nature and the moment it is returned to nature. In other words it relates to the complete life cycle of a material. “Life cycle thinking” has been defined as an approach that takes - in some way or another – economic, social and environmental impacts as they occur throughout the life cycle into account. It is not to be confused with the more specific term “life cycle analysis” which relates to a specific scientific tool that can be used – among others – to implement life cycle thinking. The waste definition remains unchanged as any substance or object that the holder discards, intends to discard or is obliged to discard. This definition is open to various interpretations. Therefore, the new decree contains a chapter solely devoted to the difference between waste and non waste.

The waste framework directive has the waste hierarchy as one of its basic principles. The terminology used in this hierarchy has been clearly defined. The definition for recovery no longer uses the annex with R codes as the main reference. There is now a stand alone definition that takes the replacement of primary materials by waste as the main criterion to judge whether a waste treatment is to be considered as recovery. This was taken from former jurisprudence of the European Court of Justice. Remarkably, reference is made to the primary result and not to the primary objective of the treatment, in contrast to former court cases. This will make it more objective to judge whether a treatment is to be regarded as recovery, as the intention no longer counts. However, there is still some room for interpretation as disposal has been defined as any waste treatment that is not recovery, even if there is a replacement of primary materials, be it as a secondary consequence. Clearly, the efficiency by which the replacement is taking place will determine the difference between recovery and disposal. Recycling has also been clearly defined. Remarkably, recycling has been defined as any waste treatment that keeps waste (or materials in general) in a closed cycle. Energy recovery or even the transformation of waste into fuels is not considered as recycling. The same applies to waste treatments that are similar to landfilling, such as backfill operations in old mines. In this way, recycling is clearly distinguished from the two lower steps of the hierarchy.

## **2.2 General objectives of the Flemish materials decree**

The material decree serves a double purpose. First of all the decree needs to contribute to creating sustainable material cycles in which human health and the environment are protected from the negative impacts of waste generation and treatment. Secondly, the decree needs to contribute to the preservation of natural resources (defined in its

broadest sense as natural capital in the form of raw materials, clean air, water, soil, renewable and non renewable energy, biodiversity, climate).

This overarching objective is further detailed by making reference to the waste hierarchy laid down in the waste framework directive. However, this hierarchy has been transformed into a material hierarchy so as to be in line with a material management approach. The first step of the hierarchy is not only referring to the prevention of waste but to the establishment of sustainable production and consumption patterns in general. This means that we want to lower the environmental impact of production and consumption in general and not only the generation of waste. In practice, when laying down measures, they will be aimed at lowering several impacts at the same time, and not only at lowering the generation of waste. The third step is the recycling of waste, together with the use of materials in general in closed material cycles. This means that even if a material is not a waste from a legal point of view, policy measures should be in place that diverts these materials away from energy applications. From a materials management approach what really matters is the nature of the material and not its legal status. For instance, if we have determined based on life cycle thinking that specific kinds of wood should better be used as raw material and not as a fuel, this premise is valid not only if the wood has the legal status of “waste”, but also if the wood has the status of “product”. After all, it is only the technical nature of the wood that determines its environmental impact and its most appropriate application and not its legal status. Therefore the third step is not limited to waste recycling but also to materials use in closed cycles in general. In line with this, the fourth step “other recovery, e.g. energy recovery” has been extended to use of materials as fuels.

The hierarchy is not to be applied as a dogma. We always have to strive towards the best environmental outcome, seen from a life cycle perspective. This means that we have to deviate from the hierarchy if it is demonstrated that this is actually better for the environment based on life cycle thinking. This means for instance that if we want to compare recycling to energy recovery, we do not only have to look at the environmental impacts that occur during the recycling or incineration itself, but also have to take into account the impacts that are avoided by replacing primary materials by recycled materials or fuels by waste. We also have to examine whether mixed waste can be separated at source so as to avoid that we end up with a waste stream that can only be incinerated. We also have to look at possibilities to design products in such a way that they are better reusable or recyclable. And we also have to look at logistical systems that guarantee that the recyclable product is actually returned for recycling once it has become waste.



The hierarchy in the materials decree is an obligation for policy makers to design measures in such a way that they steer citizens and companies behaviour towards the hierarchy. It is not imposed as a direct obligation to every individual citizen or company.

The materials decree foresees a procedure for deviating from the hierarchy. If a certain policy measure would work against the hierarchy, its deviation from the hierarchy needs to be motivated by a consultation platform that consists of all relevant stakeholders (involved public authorities, NGO's, companies...) that are part of the material cycle under question. This platform needs to be consulted by the competent waste authority before a policy measure can deviate from the hierarchy. It is this platform that needs to perform the "life cycle thinking exercise". The diverse composition of this platform will need to guarantee that no elements are overlooked during this exercise.

Working with the hierarchy and with life cycle thinking will be a learning process. Any one who has tried to perform a life cycle thinking exercise, knows how difficult it is to mark the system barriers, to formulate the right questions and preassumptions and to gather the necessary data. Engaging the right stakeholders to evaluate what are the best options and organising consultation with different parties, is another difficult task. However, it is a process policy makers will have to go through if they want to formulate a more integrated, efficient and effective, scientifically underpinned policy that is also socially accepted.

### **2.3 Marking the difference between waste and non waste**

The waste definition is quite subjective because it refers to the intention of the holder. In the past, the waste definition has lead to a lot of different interpretations in particular cases. The new waste framework directive has tried to clarify the distinction between waste and non waste by devoting more attention to end of waste and byproducts and to delineating what materials fall under the scope of the directive. These principles have also been transposed in the Flemish materials decree.

Firstly, there is an article that clarifies what material streams are never to be treated as waste. This does not mean that these materials are excluded from the scope of the materials decree. It only means that some materials are not to be treated as waste in the framework of the materials decree, namely gaseous effluents and CO<sub>2</sub> that is captured and stored, animal manure that falls within the scope of manure legislation, waste water, unexcavated soil and buildings permanently connected to the soil and radioactive waste.

Secondly, there is an article that clarifies when a waste ceases to be waste. This article is based on article 6 of the Waste Framework Directive. Apart from the end of waste criteria that will be laid down in a TAC procedure and implemented via a Regulation, the

Flemish materials decree foresees the possibility to lay down Flemish end of waste criteria for those waste streams for which no European end of waste criteria exist. The waste framework directive explicitly foresees the possibility for Member States to lay down end of waste criteria on a „case by case“ basis. The question is if this „case by case“ is to be interpreted as „company X produces waste Y on moment Z“ or as a specific waste stream that needs to fulfill certain criteria in more general terms. Our interpretation is the latter, as the waste framework directive explicitly states that if Member States make use of the possibility to mark the end of waste, technical standards or criteria should be notified to the Commission. We do not think that the Commission wants to receive all the decisions made in „company X produces waste Y on moment Z“ cases. Moreover those very specific cases would not even be based on general criteria or standards, so there would be nothing to notify. Therefore, we think that the case by case decisions refer to specific criteria that have been laid down for specific waste streams on a national level. The Flemish materials decree foresees the possibility of laying down very specific end of waste criteria. These criteria have to be set up under the same conditions as those laid down in the waste framework directive. This enables the Flemish authorities to maintain existing standards, for instance, for compost and other biological waste streams to be used as soil improver, for recycled aggregates to be used as construction material or for excavated soils that are used in another location. More clearly than before, the „end of waste“ will always be placed at the end of a process and not at the beginning of a process. In other words, the one who is treating the waste and wants to place the recycled material as a non waste on the market, will have to make sure that the end of waste criteria have been fulfilled at the moment he places the material on the market and that the product legislation, such as REACH, is fulfilled.

Thirdly, there is an article in the Flemish waste decree that implements article 5 of the Waste Framework Directive on byproducts. The criteria that need to be fulfilled to be classified as a byproduct are very similar to the end of waste criteria. Actually, we think that if a waste stream is not good enough to be qualified as „end of waste“, it should not be good enough to be labelled as a „byproduct“ either and vice versa. To avoid that end of waste criteria can be circumvented by qualifying a material stream as a byproduct or vice versa, in this way creating legal uncertainty, we have foreseen that end of waste criteria developed for specific waste streams will also apply as criteria for labelling these material streams as byproducts.

## **2.4 New policy instruments for sustainable materials management**

The new Flemish materials decree foresees the basis for the main policy instruments that will be used in a sustainable materials management policy.

Planning instruments are foreseen in the form of plans and programs that need to be laid down under certain requirements. As a minimum, waste management plans and prevention programs need to be set up according to what is required by the waste framework directive. However, the possibility has been foreseen to upgrade these plans and programs to fully integrated plans or programs that do not only handle the prevention or management of waste, but address several measures that are to be taken in one or more material chains to lower the environmental impact over the complete life cycle and covering not only waste management aspects but also other aspects such as energy efficiency, lower direct and indirect emissions to environmental media, biodiversity etc. The added value of these plans/programs is that they start from a holistic view on a complete life cycle of certain products and not from isolated aspects of this life cycle, such as waste management.

Market based instruments form another important pillar of the materials decree. They come in different forms. There is the extended producer responsibility which can be imposed on more products or waste streams than what is required under existing European directives. There is the polluter pays principle that foresees the possibility to allocate the costs of waste management to the most appropriate actors in a material chain. This forms for instance the basis for continuing household waste charging schemes. There is the possibility to grant subsidies to companies or local communities that undertake initiatives to lower the environmental impact of materials use. There is a requirement to green all public procurement by local and regional authorities. There is a possibility to lay down taxes on specific waste treatments such as landfilling or incineration.

Regulatory instruments have also been foreseen. A novelty here is that not only the treatment of waste can be regulated (such as a landfill or incineration ban), but also the use of materials that are non waste. In particular, this possibility will be used for imposing certain requirements on the use of materials that have lost their waste status so as to guarantee their environmentally sound application. There is also the possibility to lay down specific requirements on the separate collection and recycling of specific waste streams. The materials decree also foresees the life cycle approach when granting environmental permits. Classical environmental permits tend to focus on limiting environmental risks to their immediate environment due to emissions to air, water and soil. The question whether a specific activity makes sense from a life cycle perspective has until now received less attention. Aspects such as materials efficiency, achieved recycling rates, the output of certain recycling processes, etc. are often overlooked if they are not relevant in assessing the environmental risk to the immediate environment. Therefore the materials decree foresees the possibility to take these life cycle aspects into consideration when granting a permit.

The materials decree also foresees the requirement for waste producers and waste handlers to register data on waste quantities generated and treated, not only for hazardous waste, as foreseen in the waste framework directive, but for all waste. The possibility has been foreseen to lay down obligations on monitoring quantities of materials (also non waste) that are produced or consumed, so as to be able to better monitor material flows.

### **3 Conclusion**

For a large part the new Flemish materials decree will build upon the old waste legislation and guarantee the continuation of the successes of Flemish waste policy of the past 20 years, a policy that was mainly focused on diverting waste from landfills and incinerators by stepping up recycling. The new materials decree will contribute to widening this waste policy to a materials policy that has a much wider focus, namely lowering the environmental impact of materials use over their complete life cycle. This policy will have to be shaped in the coming years and will require a lot of cooperation, both between different public authorities active in different policy domains as between public authorities, industry and NGO's.

# Greece confronted with the new Waste Framework Directive

Avraam Karagiannidis<sup>1</sup> and Kyriakos Oikonomou<sup>2</sup>

<sup>1</sup>Aristotle University Thessaloniki, Greece

<sup>2</sup>Macedonian Paper Mills, Gefyra, Greece

## Abstract

This study assessed greenhouse gas emissions of different municipal solid waste treatment technologies currently under assessment in the new regional plan for Attica in the frame of addressing the country's contemporary waste management challenges.

## Keywords

Greenhouse gas emissions, waste management scenarios.

## 1 Introduction

Waste management (WM) activities and especially disposal of waste in landfills that generates methane (CH<sub>4</sub>) contribute to global Greenhouse Gas (GHG) emissions approximately by 4%. In Greece, the main method of solid WM remains landfilling; apart from this, 22 Material Recovery Facilities (MRF) are in operation for source segregated recyclables, 5 Mechanical-Biological Treatment (MBT) plants exist in 2010 (4 operating) and 8 more MBT are planned and expected to be constructed in the period between 2010 and 2020. In Attica Region (Greater Athens area) 2,200,000 t Municipal Solid Waste (MSW) (wet weight) were generated in 2008, of which 12% were recycled and 350,000 t were treated in the existing MBT plant (Figure 1). Taking into account the current Hellenic WM policy, the forecasted population growth and the anticipated waste growth, 2,800,000 t MSW are expected to be generated annually by 2030 (Figure 1). Considering the above, new WM infrastructure is necessary in order to meet the targets of the Landfill Directive 99/31/EC. The aim of the present study is to assess the GHG emission impacts of the proposed technologies for the Integrated Waste Management Centre (IWMC) in W. Attica in the context of different scenarios. The waste treatment technologies include Mass-Burn Incineration-Waste-to-Energy (WtE), Mechanical Treatment (MT) and MBT. The MBT process may be either aerobic composting or anaerobic digestion (AD) or bio-drying. Within this study MBT with aerobic composting is defined as MBT(C), MBT with AD as MBT(AD) and MBT with bio-drying MBT(BioD). Within this study, the term Solid Recovered Fuel (SRF) is used for fuels derived by MBT(BioD) while the term Refuse Derived Fuel (RDF) is used for fuels derived by MT, MBT(C) and MBT(AD) plants.

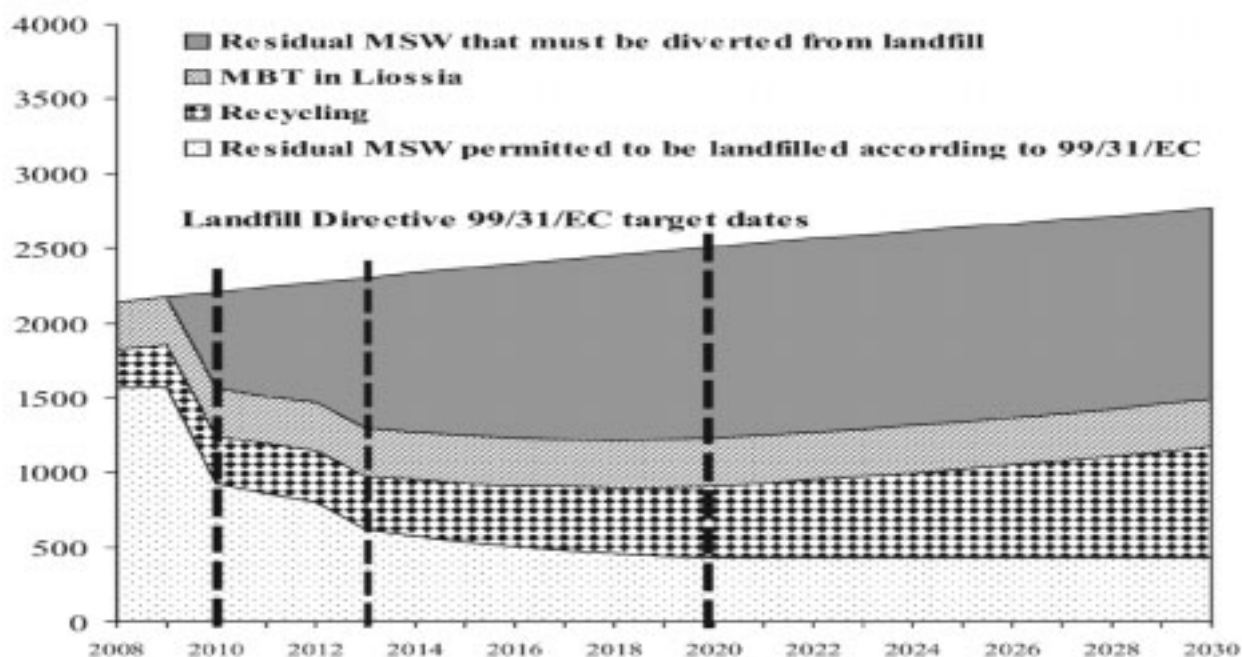

Figure 1 Foreseen MSW management in Attica until 2030 according to existing facilities

## 2 Materials and methods

The present study aimed to quantify Carbon Dioxide (CO<sub>2</sub>), Methane (CH<sub>4</sub>) and Nitrous oxide (N<sub>2</sub>O) emissions from WM activities in 5 Attica scenarios under assessment. For the quantification of GHG emissions from the treatment of MSW in each of the scenarios, a validated methodology (Papageorgiou et al, 2009) was adopted and Emission Factors (EFs) were sourced from previous studies that assessed the GHG emissions impact of MSW treatment technologies and were applied in this study adjusted to the Hellenic MSW composition. Five scenarios described next were compiled. The MSW management system for each of the scenarios is presented in Figure 2.

**Scenario 1:** 400,000 t of residual MSW are treated in a MBT(C) plant and 700,000 in a WtE. MBT(C) outputs include ferrous and aluminium metals, bio-stabilised output, residues and RDF. Metals are recovered for recycling, while the bio-stabilised output and residues are disposed in a landfill, whilst RDF substitutes coal in a cement kiln. In the WtE plant, the ferrous metals recovered from the bottom ash are sent to a reprocessor for recycling, whilst the bottom ash and the APC ash are both landfilled in a sanitary and a hazardous landfill cell respectively. The WtE plant recovers electricity only with a net electrical efficiency of 22,6 % (related to the NCV of waste), in order to be qualified as recovery operation according to the requirements new Directive on Waste (2008/98/EC) (Karagiannidis et al, 2009)

**Scenario 2:** 400,000 t of residual MSW are treated in a MBT (AD) and 700,000 t in a WtE. MBT(AD) outputs are ferrous and aluminium metals, residues and bio-stabilised



output that are disposed to landfill, RDF that substitutes coal in cement kilns and biogas combusted for electricity generation with efficiency 37%. It is assumed that 33% of the produced electricity is used in-house for plant operation and 65% is exported to the grid.

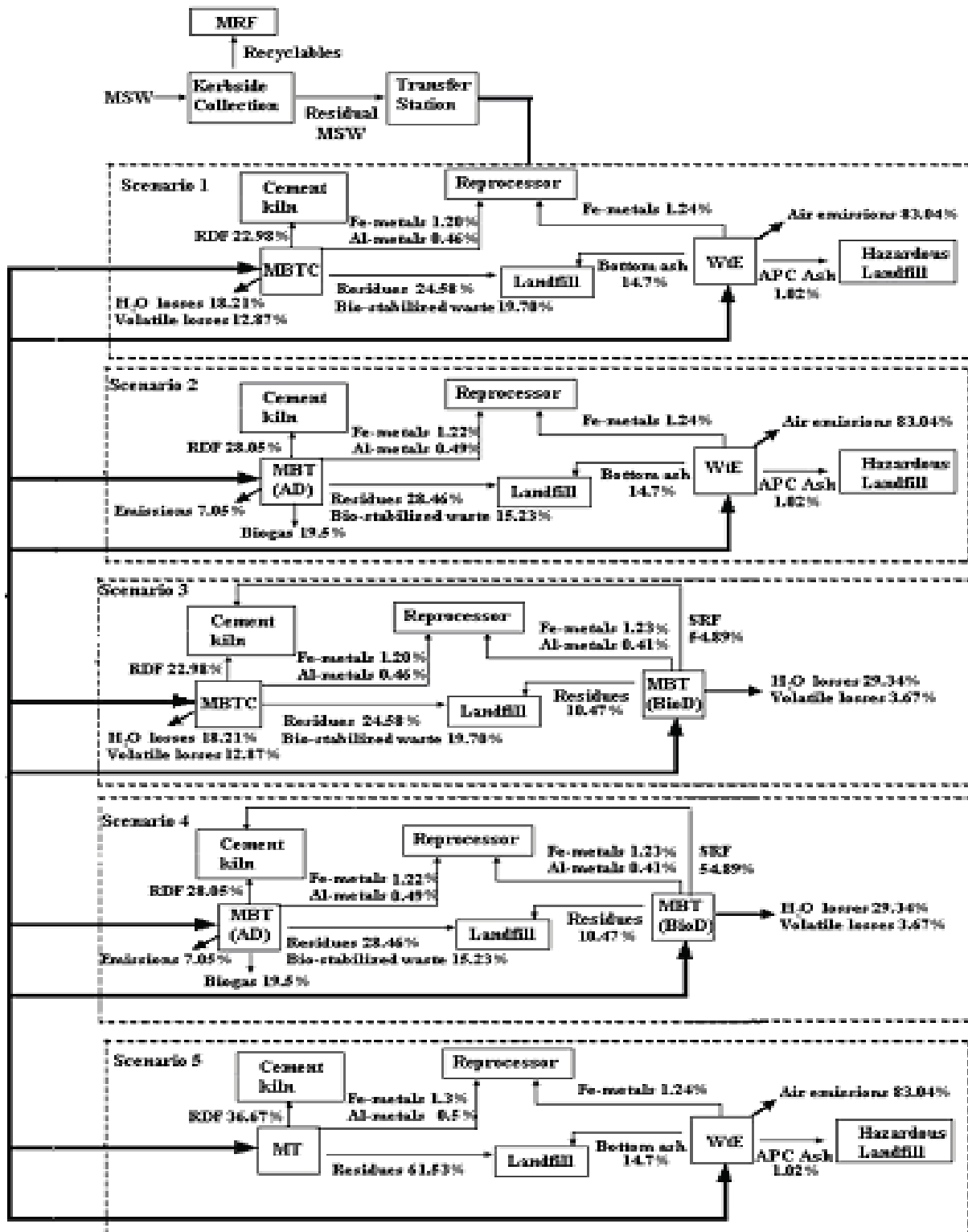

Figure 2 Waste management scenarios for the IWMC in west Attica.

**Scenario 3:** 400,000 t of residual MSW are processed in a MBT(C) (like Scenario 1) and 700,000 t in a MBT (BioD). MBT (BioD) outputs are metals sent for recycling, residues disposed to landfill and SRF that substitutes coal in a cement kiln. Ash from SRF combustion in the cement kiln is included in clinker production.

**Scenario 4:** 400,000 t of residual MSW are treated in a MBT(AD) (like Scenario 2) and 700,000 in a MBT(BioD) (like Scenario 3).

**Scenario 5:** 250,000 t of residual MSW are processed in a MT plant and 850,000 in a WtE. MT outputs are metals sent for recycling, RDF and residues that are landfilled.

In this study it was assumed that the treatment plants in each scenario treat residual MSW, after kerbside collection. For the estimation of the future residual MSW composition, it was assumed that the targets set by the Packaging Waste Directive (99/42/EC) would be met and hence 60% w/w of packaging glass, 60% w/w of paper and cardboard, 50% metals w/w, 22,5% w/w plastic and 15% w/w wood would be recycled. The residual MSW is taken as the input to the WM system of each scenario. MSW in Greece consists of: 29% paper and card, 40% kitchen and garden waste, 14% plastic, 3% inert, 2% leather wood, textiles and rubber, 3% glass, about 3% ferrous metals, 0,5% non-ferrous metals and 6% other materials. Based on the residual MSW composition, mass balances for each of the examined scenarios were compiled and are shown in Figure 2. For the quantification of GHG emissions from the treatment of residual MSW in each scenario the methodology presented in Papageorgiou et al, 2009 was applied. The EFs (kg CO<sub>2</sub>-eq/t of MSW treated) were estimated for all activities involved in the WM system of every examined scenario and converted to CO<sub>2</sub>-eq using global warming potentials for a 100-year time frame.

Table 1 Direct and indirect emission impacts included in the model

Process	Indirect-up-stream impacts	Direct impacts	Indirect-down-stream- impacts
<b>MBT (C)</b>	CO <sub>2</sub> emissions (E <sub>CO2</sub> ) associated with electricity provision	<ol style="list-style-type: none"> <li>1. E<sub>CO2</sub> from fossil fuels combustion for waste treatment</li> <li>2. CH<sub>4</sub> and N<sub>2</sub>O from composting</li> <li>3. E<sub>CO2</sub> from combustion of fossil carbon in RDF</li> <li>4. CH<sub>4</sub> emissions (E<sub>CH4</sub>) (landfilling)-CO<sub>2</sub> from fuels consumption-no CH<sub>4</sub></li> </ol>	<ol style="list-style-type: none"> <li>1. CO<sub>2</sub> savings from metals recycling and from substitution of fossil fuels (coal) by RDF in cement kilns</li> </ol>
<b>MBT (AD)</b>	Electricity for the operation of plant is provided by the electricity generated by the combustion of biogas	<ol style="list-style-type: none"> <li>1. E<sub>CO2</sub> from fossil fuels combustion</li> <li>2. Efficient recover of CH<sub>4</sub> from digestion - no leakage takes place</li> <li>3. E<sub>CO2</sub> from combustion of fossil carbon in RDF</li> <li>4. E<sub>CH4</sub> from residues landfilling-CO<sub>2</sub> from fuels consumption-biostabilized output does not generate methane</li> </ol>	<ol style="list-style-type: none"> <li>1. CO<sub>2</sub> savings from electricity substitution (biogas combustion)</li> <li>2. CO<sub>2</sub> savings from metals recycling and coal substitution by RDF in cement kilns</li> </ol>

<b>MBT (BioD)</b>	$E_{CO_2}$ associated with electricity provision	<ol style="list-style-type: none"> <li>1. <math>E_{CO_2}</math> from fossil fuels combustion</li> <li>2. <math>E_{CO_2}</math> from the combustion of fossil carbon in SRF</li> <li>3. <math>E_{CH_4}</math> from landfilling of residues - <math>CO_2</math> from fuels consumption</li> </ol>	<ol style="list-style-type: none"> <li>1. <math>CO_2</math> savings from metals recycling and from substitution of fossil fuels (coal) by SRF in cement kilns</li> </ol>
<b>WtE</b>	Electricity for the operation of plant is provided by the electricity produced on-site	<ol style="list-style-type: none"> <li>1. <math>E_{CO_2}</math> from the combustion of waste fossil fraction and fossil fuels for WM</li> <li>2. <math>N_2O</math> emissions</li> <li>3. <math>E_{CO_2}</math> from fuels consumption for landfill operation where ash is disposed</li> </ol>	<ol style="list-style-type: none"> <li>1. <math>CO_2</math> savings from electricity substitution and from recycling of ferrous metals recovered from bottom ash</li> </ol>
<b>MT</b>	$E_{CO_2}$ associated with electricity provision	<ol style="list-style-type: none"> <li>1. <math>E_{CO_2}</math> from fossil fuels combustion</li> <li>2. <math>E_{CO_2}</math> from the combustion of fossil carbon in RDF</li> <li>3. <math>E_{CH_4}</math> from residues landfilling-<math>E_{CO_2}</math> from fuels consumption and electricity</li> </ol>	<ol style="list-style-type: none"> <li>1. <math>CO_2</math> savings from metals recycling and coal substitution by RDF in cement kilns</li> </ol>

### 3 Results and discussion

From figure 3, it can be seen that all scenarios under assessment in this study could generate GHG emission savings. Scenarios 3 and 4 perform better, followed by 2, 1 and 5. Scenario 3 incorporates MBT(C) with RDF production and MBT(BioD) with SRF production. Both fuels were assumed to substitute coal in cement kilns or paper mills. In general, the performance of all scenarios and especially scenarios 3 and 4 are strongly dependent on the existence of a market for the produced RDF and SRF. However the market for these fuels is extremely volatile and there many cases where these fuels end up in landfills instead of being utilized for energy recovery.

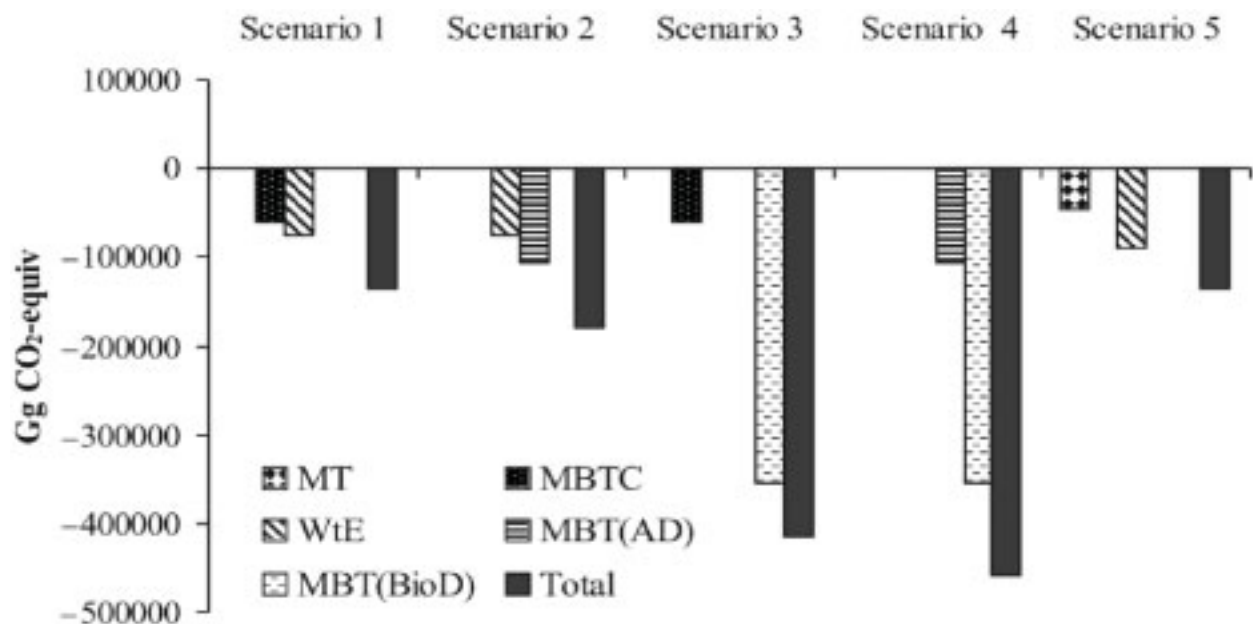

Figure 3 GHG emissions (kg CO<sub>2</sub>-eq.) for all five scenarios

The sensitivity analysis aimed to evaluate what would be the GHG emission impact in the case where there is no end market for the produced RDF and SRF from the MT, MBT(C), MBT(BioD) and MBT(AD) plants in the assessed scenarios. In this case the GHG emission savings from the recovery of energy from these fuels should not be taken into account, whereas potential CH<sub>4</sub> production from the degradation of the biodegradable content of these fuels should be assessed, if they are finally disposed in a landfill. Especially a MBT(BioD) plant incorporates a bio-drying process, that does not reduce the biodegradable content of the waste or it reduces only a small amount of it, about 10% (Archer et al, 2005) and thus the disposal of SRF in landfill will surely generate CH<sub>4</sub>. Moreover, RDF in the MBT(C) and MBT(AD) plants is recovered before the biological process and thus the biodegradation of their organic fraction due to disposal in landfills will generate CH<sub>4</sub> as well. In the analysis it was assumed that the WtE facilities in scenarios 1, 2, 5 will increase their capacity and finally combust the surplus RDF from the MBT(C), MBT(AD) and MT respectively. On the other hand in scenarios 3 and 4, where no thermal treatment plant is foreseen, it was assumed that the produced RDF and SRF will finally end up in landfill. The performance of all scenarios depends strongly on the existence of an end market for the recovered RDF and SRF. Especially scenarios 3 and 4 generate net GHG emissions and thus the treatment of residual MSW in these scenarios, offers no benefit, at least on GHG emission savings. Therefore, in the event that a SRF market does not exist, then probably further aerobic treatment for RDF and SRF will be necessary in order to reduce its biodegradable content, since they will be disposed in landfills. On the other hand, scenarios 1, 2 and 5 can provide GHG emission savings as they incorporate WtE and MBT(AD) which recover electricity for which the demand is constant.

## 4 Conclusions

The presented study has shown that all scenarios under assessment could save GHG emissions provided that there is an end market for the recovered RDF and SRF. In this case the co-incineration (e.g. in cement kilns or paper mills) of SRF from MBT (BioD) mainly and RDF from MBT(C), MBT(AD) and MT can generate significant emission savings. It should be also commented here that waste policy and planning in Greece for the moment does not promote waste minimization measures neither poses high recycling targets and instead promotes technologies and plants of large capacity that will treat mixed residual waste. Thus, the potentials of waste minimization measures such as home composting and Pay-As-You-Throw schemes in conjunction with new waste treatment plants should be utilised, combined with maximised recycling and reuse.

## 5 Literature

- Papageorgiou A., 2009 *Assessment of Greenhouse Effect Impact of Technologies*  
Barton J.R, *Used for Energy Recovery from Municipal Waste: A Case for*  
Karagiannidis A. *England. Journal of Environmental Management.*

### Authors' addresses:

Assoc. Prof. Dr.-Ing. Avraam Karagiannidis  
Aristotle University Thessaloniki  
Box 483, University Campus  
GR-54124 Thessaloniki  
Telefon +30 2310 99 41 65  
Email: akarag@auth.gr  
Website: aix.meng.auth.gr

Mr. Kyriakos Oikonomou  
President and Managing Director  
Macedonian Paper Mills  
GR-57011 Kato Gefyra, Thessaloniki  
Telefon: +30 2310 72 81 07  
Email: admin1@melpaper.com  
Website: www.melpaper.com

# Waste Management in Romania: past and present

E. C. Rada, T. Apostol, M. Ragazzi, I. A. Istrate

\* Department of Energy Production and Use, Politehnica University of Bucharest, Romania,

\*\* Department of Civil and Environmental Engineering, University of Trento, Italy,

## Abstract

In Romania, as well as in other countries, the impact of waste on the environment has increased at an alarming rate during the past 20 years. On the 1<sup>st</sup> of January 2007 Romania became one of the European Union members and had to apply all the European regulations regarding waste. This paper presents data regarding the waste management in Romania in the past and in the present, taking into account also specific results from two co-supervised international researches. Romania must strongly modify the sector of landfilling because of a significant presence of dump sites (that require site remediation interventions). Selective collection is growing but gives today only a small contribution to the overall waste management. Bio-mechanical plants could be constructed also to exploit the availability of industrial plants suitable for co-combustion.

## Keywords

management, landfilling, municipal solid waste, regulation, site remediation, Romania

## 1 Introduction

In Romania, as well as in other countries around the world, the impact of waste on the environment has increased at an alarming rate during the past 20 years. The inappropriate management of this problem has caused soil, subsoil and groundwater contamination, fugitive emissions of methane and toxic gases, with direct impact on the public health.

One of the biggest problems that Romania encountered before and after the entrance in the European Union (EU) is the waste management policy. On the 1<sup>st</sup> of January 2007 Romania became one of the European Union members. The European Association Agreement stipulates that Romanian development policies must be guided by the principle of sustainable development and take full account of environmental considerations. For this reason Romania began to implement the EU principles on waste management trying to put, in the first place, waste prevention, in the second one recycling and energy generation, and in the last one disposal of waste with no recovery of either materials and/or energy.

Since 2007 Romania has to apply all the European regulations regarding waste and for this reason a National Waste Management Plan was developed taking into account the



European and the National legal provisions (Framework Council Directive 75/442/EEC on waste, amended by Council Directive 91/156/EEC, Council Directive 91/689/EEC on hazardous waste). It must be pointed out that a significant part of the European Directives were adopted even before 2007, but their implementation encountered some difficulties. According to the Governmental Emergency ordinance 78/2000 modified and approved through the Law 426/2001, the National Waste Management Plan is valid for municipal solid waste (MSW), for sludge from municipal wastewater treatment plants, for construction and demolishing waste and for other non-hazardous and hazardous special waste.

The present paper deals with the waste management in Romania in the past in the present and in the future taking into account specific results from two co-supervised international PhD researches.

## **2 Romanian waste management situation before entering in the EU**

In 1993, as a result of a contract between the Ministry of Waters, Forests and Environmental Protection and the Institute for Research and Developing for the Environmental Protection, Bucharest, a data base for waste generation and management was created (Romanian inventory made in conformity with the Government Decision 155/1999). Data refers both to industrial wastes and to municipal solid waste (MSW). A new Waste List including also the hazardous wastes was set by the Government Decision no. 856/2002. Moreover, Romania reported data concerning waste since 1995, to EUROSTAT and to the European Agency for Environment (through EIONET).

Since 1998, the percentage of urban population who benefitted of the sanitary services increased arriving in 2006 to 48.84 at national level (about 80% in the urban area and about 12 at rural level); about 95% of waste were landfilled every year in open dumps. Generally, in Romania a person generates daily about 0.9 kg<sub>MSW</sub> at urban level and about 0.4 kg<sub>MSW</sub> at rural level. The percentage of biodegradable matter in the MSW decreased slowly during the years and at rural level the quantity of biodegradable material is 10% bigger than the one in the MSW at urban level. This trend can be explained by the increase of packaging in the waste. In Figure 1 the MSW composition during the years is presented (ANPM, 2010).

Since 1991 Romania has demonstrated attention to the international waste shipment, accessing to the Basel Convention. With the Order No.2/2004 for Procedure and regulatory approval controls on waste transport, modified and completed by the Order MA-PAM No.986/2006, Romania completed its regulation on shipment.

In 2002, after the implementation at local level of some pilot selective collection experiences (related only to the valuable materials) it was seen that the adopted methods were insufficient to recover a significant part of the recyclable materials. Due to the selective collection in pilot projects, 2% of the total quantities of recyclable materials were recovered. The rest was disposed of, losing large quantities of secondary raw materials and energy resource.

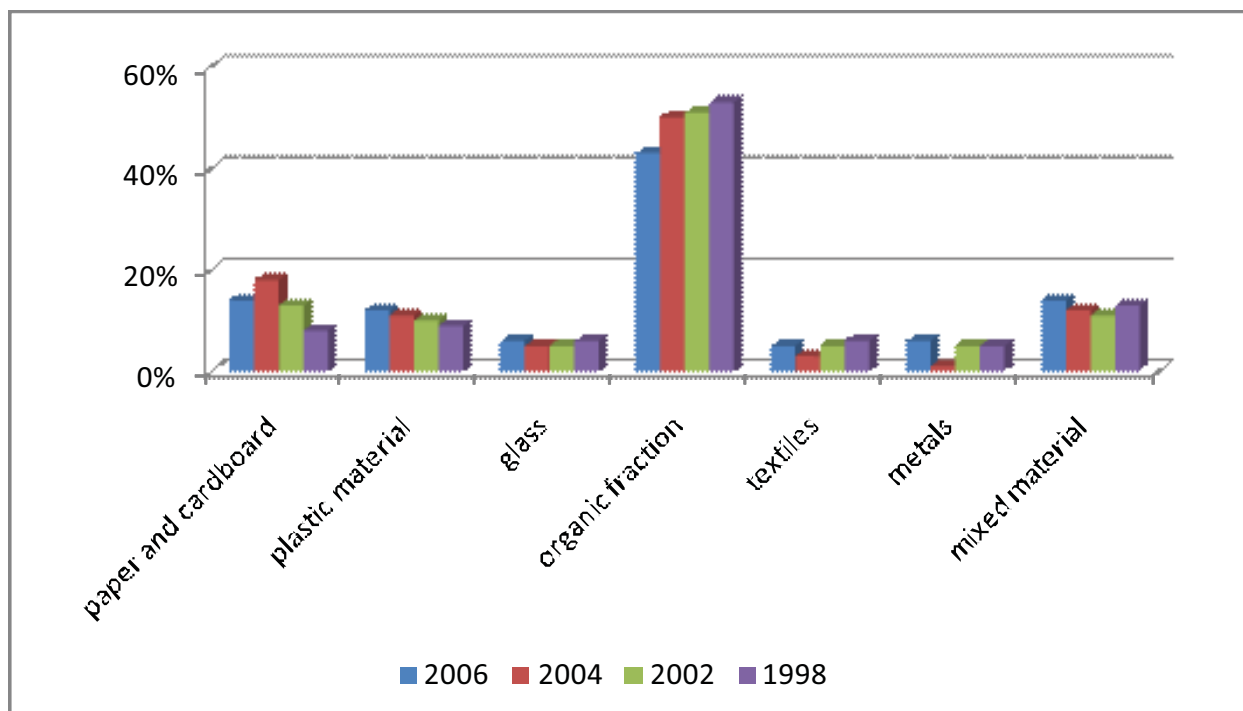

Figure 1 Average percentage of MSW composition for 1998 to 2006

The Governmental Decree No.162/2002 on waste pointed out the necessity of reducing the quantity of biodegradable waste disposed of. The imposed target is 25% less until 2011, taking into account the quantity of biodegradable waste produced in 1995. In 2005 with the governmental decision No. 621/2005 the management of packaging has been introduced.

In some regions, thanks to EU funds like ISPA and PHARE, between 2003 and 2004 some small projects regarding the integrated MSW management were implemented (for instance, composting and selective collection of sellable materials and also construction of transfer stations).

In 2003 in the north-central part of Romania, a composting micro pilot plant placed in a landfill site was implemented. In 2006 it produced about 100 t of compost, demonstrating the micro-scale of the initiative. This compost were used on public lands, in greenhouses and on the existing waste landfill close to the plant.

In 2004 an evaluation of landfills from urban areas was done and resulted in an inventory of 240 landfills that were operating not complying with the European requirements on landfilling (MESD, 2007). Most of those were mixed waste landfills (60%) accepting for disposal both domestic, construction and demolition waste but also non-hazardous industrial waste. Over 40% of those had no environmental protection facilities and more than 45% had only a fence enclosure (in practice they were dump sites). About 80% of waste landfills occupied relatively small areas (between 0.5 and 5 ha), and the rest of 20% were large MSW landfills, occupying areas from 5 ha to over 20 ha. The number of small landfill sites in rural areas is still unknown. In 2004 approximately 2,686 waste deposit spaces in rural areas were identified with an area of less than 1 ha (MESD, 2007; EEA, 2009). In 2002, only 10% of MSW landfills were authorized by the local Environmental Protection Agency.

In 2005 a study regarding the inventory of polluted sites and the history of intervention priorities based on a risk analysis were developed. As a result of irrational interventions (pollution by industrial activities, storage of waste or inappropriate agricultural work performance), a series of negative effects are accentuated as compaction, destruction of soil structure, depletion of nutrients, resulting in diminishing soil fertility used in agriculture.

The Accession Treaty Romania – European Union, signed on the 25<sup>th</sup> of April 2005 includes concrete commitments of Romania regarding the “*acquis communautaire*” implementation. This treaty underlines also some deadlines for the implementation of environmental obligations (up to 2015 for industrial installations with high pollution degree, 2016 for municipal waste landfill, and 2018 for the expansion of urban collection and wastewater treatment).

### **3 Romanian waste management situation after entering in the EU**

Collection, recycling and waste treatment are a priority and is reflected in the commitments made by Romania to the European Union. The law with the directives on waste sorting is the Law 27/2007.

In 2007, Regional Waste Management Plans were made starting from the National one presented in 2004. In 2008 the plans were developed at Province level. This last plans have present in deeper details the objective and the action that must be implemented in short, medium and long term.

Romania obtained a transition period to comply with EU Directives for MSW landfilling until 2017 (having to close 139 landfills until the 16<sup>th</sup> of July 2009 and other 101 until the

16<sup>th</sup> of July 2017). Temporary landfilling rules for hazardous waste were set until 2009 and hazardous industrial waste landfilling until 2013.

Romania has to comply carefully with the planned closure of landfilling sites in order to avoid the starting of infringement procedure by the European Commission. Also, if this problem will not be solved, a hard penalty for each day of delay will be applied to Romania starting with 2010.

Romania has the possibility to postpone of 4 years the achievement of targets to reduce the biodegradable municipal waste by 25% until 2010 and 50% before 2013.

By the year 2013 the annual amount of biodegradable waste that will be landfilled must decrease up to 2.4 million tones, representing 50% of the total amount produced in 1995, and some important measures for reducing landfilled waste packaging must be implemented.

The target for MSW biological treatments (composting and mechanical-biological treatment) must reach a ratio of 70% in the year 2017 (CRAC, 2004). It has been pointed out that an incorrect management of toxic waste (that could be collected together with MSW) could give an unexpected impact from biological treatments (RADA ET AL., 2008).

By the year 2013 it is foreseen a recovery degree of useful materials from waste packaging (for recycling or incineration with energy recovery) as 60% for paper or cardboard, 22.5% for plastics, 60% for glass, 50% for metals and 15% for wood (MESD, 2008). Also special measures are foreseen between 2008 and 2013 for the recovery of waste electrical and electronic equipment (ISTRATE ET AL., 2009) and also for the closure of incineration installations of hospital waste that are not made according to the EU standards.

The proposed targets for 2015 are the creation of 30 integrated systems of waste management at regional / county level, the closure of 1,500 small landfills located in rural areas and of 150 old landfills in urban areas; the achievement of 5 pilot projects for the remediation of historically contaminated sites is an additional target (MESD, 2008).

One of the future aims is also the development of an integrated waste management by improving waste management and reducing the number of historical polluted areas in at least 30 counties by 2015.

For these activities an amount of 1.7 billion € will be necessary, whose 80% can come from European Regional Development Funds.

Currently, in Romania there are no operating incinerators for MSW. The composition and the characteristics of MSW in Romania (moisture about 50% and calorific value

less than 8,000 kJ/kg<sub>MSW</sub>) and the higher costs of this option do not allow incineration today. The expected trend in the characteristics of waste will change this scenario.

Taking into account the past, present and future scenarios of waste management in Romania, the Politehnica University of Bucharest (Energy Faculty, Department of Energy Production and Use) started a bilateral scientific and technological agreement and (since 2003) a co-supervised PhD program with the University of Trento, Italy. The involved Faculty is the one of Engineering (in particular the Department of Civil and Environmental Engineering). This Faculty was selected thanks to its international and national ranking. The aim was to study and develop together some technologies regarding two important sectors of the waste management in Romania:

- Mechanical-biological treatments of MSW (bio-drying treatment) aimed to energy generation;
- Site remediation techniques (electrochemical treatment) for leachate contaminated soils.

## 4 Contributions from the research

Today in Romania the Refuse Derived Fuel (RDF) from MSW market is not implemented, but the RDF from MSW and its utilization is viewed in Romania as a strategic component of an integrated waste management policy because in this way the quantity of the biodegradable materials that could arrive in a landfill can be reduced as requested from the Landfill Directive from 1999/31/EC (APOSTOL ET AL., 2008). A RDF based strategy at national level could help to decrease the amount of waste (even biodegradable waste) sent to landfilling decreasing the putrescibility of the landfilled material, exploiting existing combustion plants (thermal power plants fed with coal, cement works, etc.) where a partial substitution of the conventional fuel could be organized.

Presently in Romania bio-drying plants for MSW are under discussion but not yet implemented but recently the first authorisations for co-combustion in cement works have been released but only for special waste. Bio-drying prepares the MSW to a post-treatment that can easily separate recyclable materials as glass, metals and inert leaving a final product (the refined bio-dried material) that can be classified as RDF (RAZZI ET AL., 2007). Thus this process can enlarge the sector of co-combustion in Romania. However the effects of bio-drying implementation concern also waste transportation, decreasing the mass to be moved.

In order to generate useful data for bio-drying design and management (when applied to Romanian MSW), an experimental research was developed since 2003 thanks the signing of a co-supervised research between the University of Trento, Italy and the Politehnica University of Bucharest, Romania.

For a better understanding, some results of a bio-drying run applied to the Romanian waste are presented in this paper. For developing bio-drying runs a pilot scale biological reactor was used (RADA 2005A). The runs lasted generally 2 weeks. The lower heating value (LHV) increased at the end of the process of about 30% from the MSW to the bio-dried material and of about 60% from the MSW to the RDF (obtained after the separation of inert, metal and glass from the bio-dried material) (RADA ET AL., 2005B; 2007A). In this way a waste not suitable for a good combustion (because of a low LHV) can be converted into a RDF suitable for a good co-combustion in existing plants.

The Lower Heating Value (LHV) dynamics of the present Romanian MSW, bio-dried material and RDF during the bio-drying treatment are reported in Figure 2, (RADA ET AL; 2007B]). It must be underlined that the bio-dried material and LHV increase of RDF after two weeks is respectively around 35% and 50%. This is not an energy increase because it must be taken into account that the available mass of fuel is lower after the process. After two weeks the mass loss was about 25% and the volatile solids consumption was about 33 g/kg<sub>MSW</sub>. The process allows “concentrating” the initial energy with a contemporary consumption of electrical energy. Generally the energy available at the end of the process is about 3% lower than the initial one apart from the electricity needs that changes depending on the adopted technology.

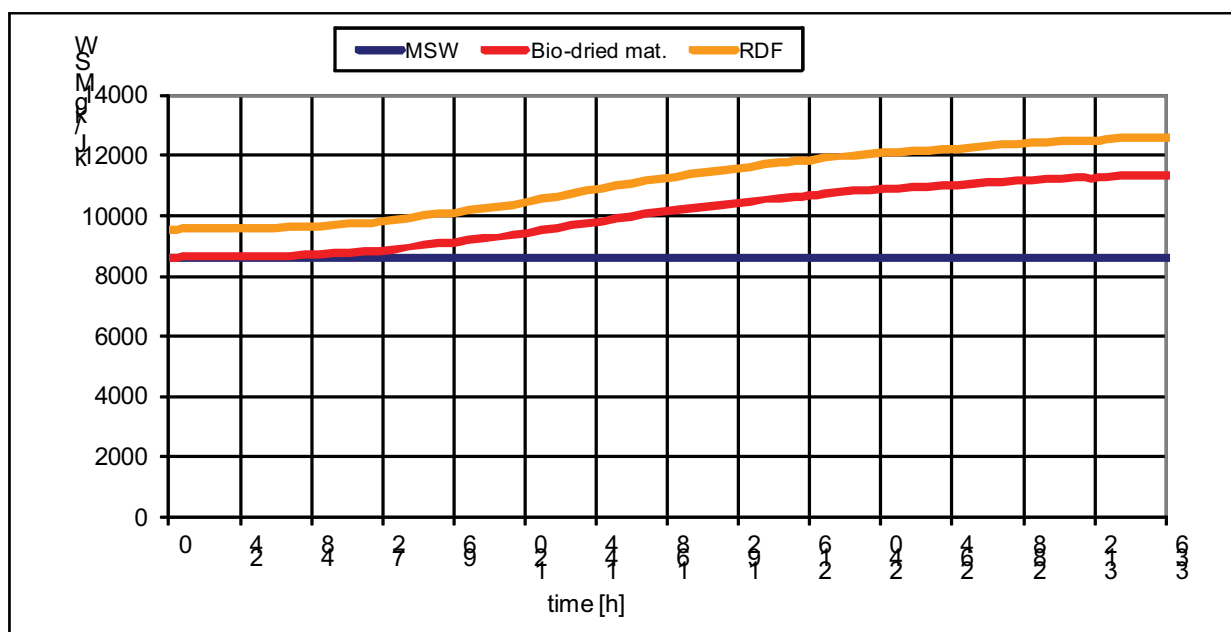

Figure 2 LHV dynamics

Since 2004 the soil pollution has been a priority topic in Romania. This is demonstrated by the Order MEWM No.344/2004 concerning the use of sewage sludge in agriculture. Anyway a need of techniques for site remediation (for dumps, refinery areas, altered agricultural soil, etc.), was clear and compulsory.



For this reason another co-supervised PhD research regarding the soil remediation research was developed since 2006 between the two cited Universities in order to set design and operation parameters to be applied to Romanian industrial polluted sites and dump sites. In this paper some results regarding Direct Current Technologies (DCTs) are presented.

Some tests were performed with a one-dimensional experimental setup for bench scale testing (ISTRATE 2009). In the Figure 3 the results of the application of this treatment to a the diesel-contaminated soil samples are presented (OPREA ET AL, 2008A,B). The removal efficiency can be interesting for real scale application.

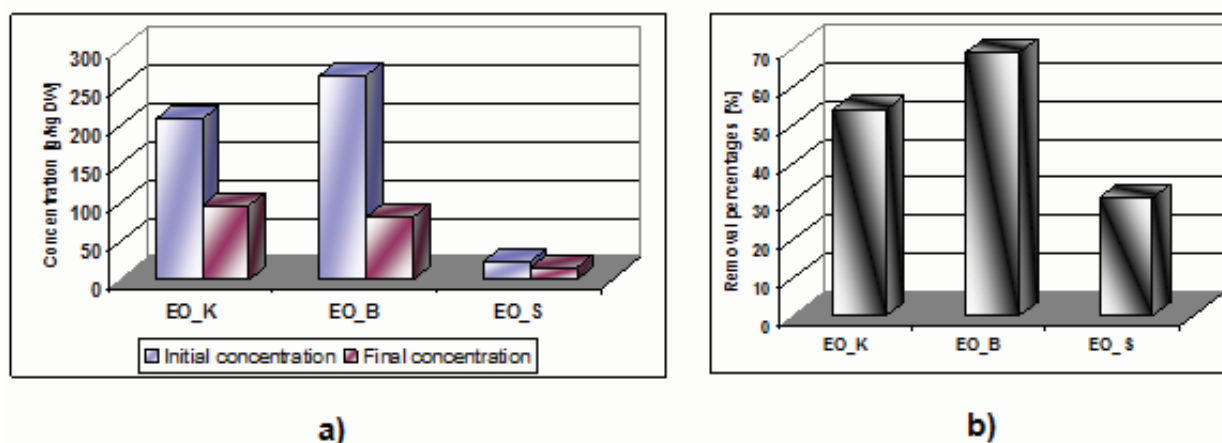

Figure 3 The final concentrations obtained after a treatment period (a) and the removal percentages achieved (b) for three samples

Another target was to evaluate the effectiveness of electro-oxidation treatment for the removal of organic substances and ammonia nitrogen from clay that have been contaminated by municipal landfill leachate.

The tests were performed on artificially contaminated clay. The clay was mixed with the landfill leachate to emulate the pollution of the clay at the bottom barrier of a landfill, deriving by a leakage in the geomembrane line. The obtained results after 1 day and after 1 week are presented in Figure 4. Also in this case the research gives important parameters for real scale application.

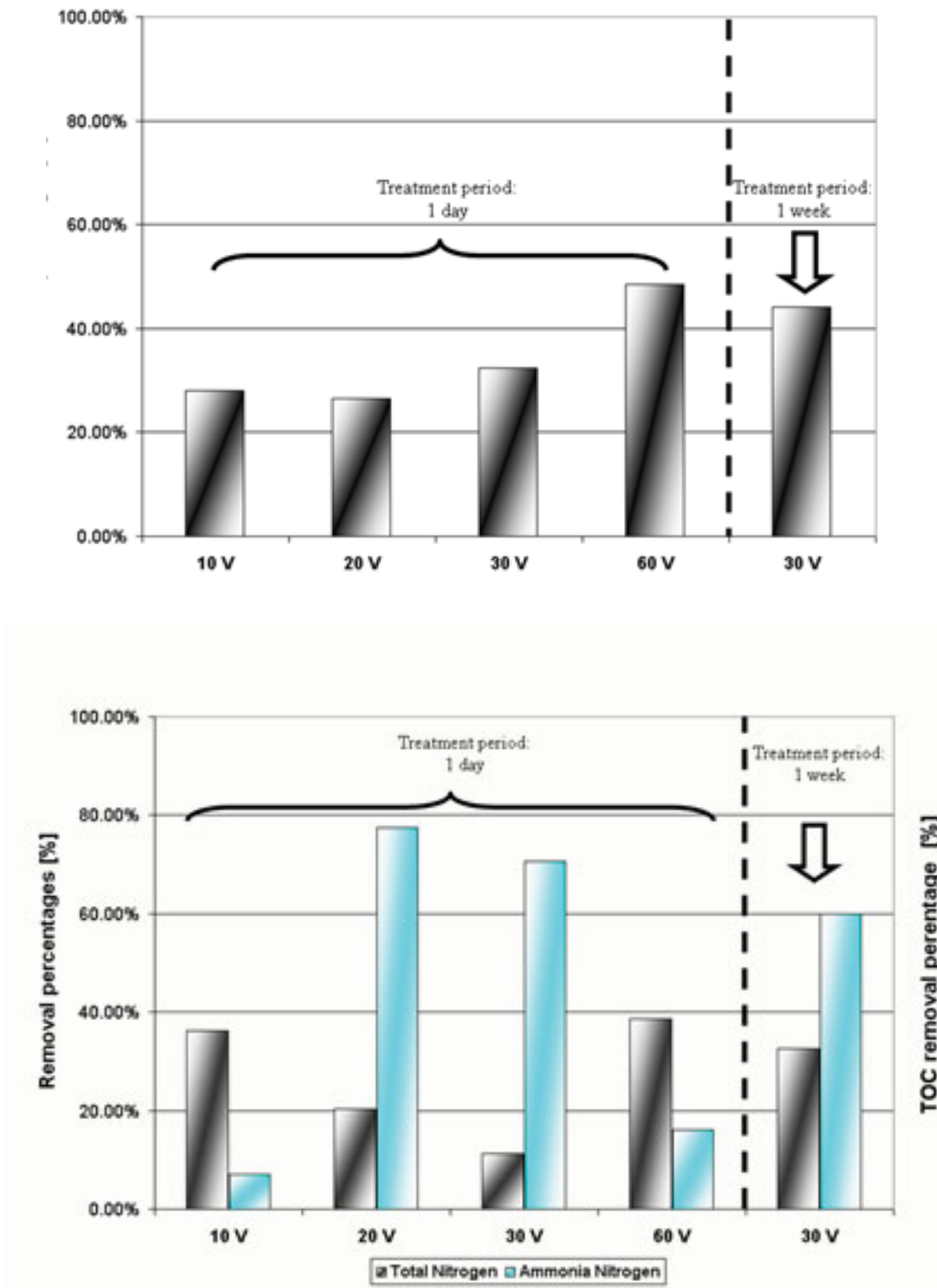

Figure 4 & 5 Removal percentages for Total Nitrogen, Ammonia Nitrogen and TOC for the tests performed for a treatment period of 1 day and 1 week with different voltage

Of course, the present step concerns the implementation of the described approaches at real scale. For this reason at the moment in Romania at regional level some initia-

tives are under evaluation concerning the co-financing of real scale plants for waste treatment and site remediation, by EU structural funds.

## 5 Literature

- |   |      |  |
|---|------|--|
| ANPM  | 2010 | <a href="http://www.anpm.ro">www.anpm.ro</a>   |
| MESD  | 2007 | Minister of Environment and Sustainable Development, Generarea si gestionarea deseurilor in anul 2005  |
| EEA   | 2009 | Diverting waste from landfill – Effectiveness of waste management policies in the European Union, European Environment Agency, Copenhagen  |
| L. CRAC   | 2004 | Waste management in Romania – scenario entrance data for the assessment of costs, ( <a href="http://www.mec.utt.ro">http://www.mec.utt.ro</a> )  |
| Rada E. C., Apostol T., Ragazzi M.  | 2008 | Toxic waste in Romanian MSW: which consequences on the health impact from MSW bio/mechanical treatment plants?, Proceed. of 1 <sup>st</sup> International Conference Hazardous Waste Management, Chania - Crete, Greece. |
| MESD  | 2008 | Ministry of Environment and Sustainable Development– MESD (2008b), National Sustainable Development Strategy of Romania 2013 – 2020 – 2030, National Centre for Sustainable Development, Bucharest                       |
| Istrate I. A., Rada E. C., Badea A., Apostol T., Andreottola G., Ragazzi M. | 2009 | Management of waste electric and electronic equipments in Romania, Proceed. of 20 <sup>th</sup> International Waste Management and Landfill, S. Margherita di Pula (Cagliari), Italia                                    |
| Apostol T., Rada E. C.,   | 2008 | Romanian MSW bio-drying for RDF generation, Proceed. of RENEXPO® South-East Europe – International Trade fair and Conference for Renewable Energy and Energy Efficient Construction and Renovation, Bucharest, Romania.  |
| Ragazzi M., Rada E. C., Apostol T., Franzinelli A., Odorizzi S.             | 2007 | Refuse Derived Fuel and the industrial sector: the Romanian perspective, Proceed. of 3 <sup>rd</sup> International Conference on Energy and Environment- CIEM 2007, Bucharest, Romania, Electrical Engineering –         |

- Scientific Bulletin, seria C, 69, 4, 489-494.
- Rada E. C. 2005a Municipal Solid Waste bio-drying before energy generation , PhD Thesis, University of Trento & Politehnica University of Bucharest
- Rada E. C., Ragazzi M., Panaitescu V., Apostol T. 2005b Energy from waste: the role of bio-drying. Stintific Buletin (Ro), seria C: Electrical Engineering, vol 67, No. 2, pp. 69-76.
- Rada E. C., Ragazzi M., Apostol T., Panaitescu V., Venturi M. 2007a Waste pre-treatment before final disposal: the Romanian perspective, Proceedings of 3rd International Conference on Energy and Environment-CIEM 2007, Bucharest, Romania, Electrical Engineering – Scientific Bulletin, seria C, 69, 4,481-488.
- Rada E. C., Franzinelli A., Taiss M., Ragazzi M., Panaitescu V., Apostol T. 2007b Lower Heating Value dynamics during municipal solid waste bio-drying, Environmental Technology, vol. 28, pp. 463-469.
- Istrate I. A. 2009 Advanced chemical and electrochemical techniques for the remediation of petroleum contaminated sites
- Oprea I. A., Andreottola G., Ziglio G., Badea A., Ragazzi M., Apostol T. 2008a The study of a real case application of electrochemical methods for a contaminated industrial site in Romania. Proceed. of 1<sup>st</sup> International Conference on Hazardous Waste Management", Chania - Crete, Greece.
- Oprea I. A., Badea A., Andreottola G., Ziglio G., Ragazzi M., Ferrarese E., Apostol T. 2008b Assessment of electrochemical technology as a treatment for diesel contaminated soil. Proceed. of International Symposium on Sanitary and Environmental Engineering, Florence, Italy.

**Author's address(es) :**

Dr. Ing. Dipl. Elena Cristina Rada  
Politehnica University of Bucharest and University of Trento  
Spl. Independentei 313, Bucharest 6, 060042, Romania  
via Mesiano 77, 38050, Trento, Italy  
Telefon +39 0461 28 2613  
Email Elena.Rada@ing.unitn.it

---

Dr. Ing. Dipl. Tiberiu Apostol  
Politehnica University of Bucharest  
Spl. Independentei 313, Bucharest 6, 060042, Romania  
Telefon +40 21 4029433  
Email tiberiuapostol80@gmail.com

Dr. Ing. Dipl. Marco Ragazzi  
University of Trento  
via Mesiano 77, 38050, Trento, Italy  
Telefon +39 0461 28 2609  
Email Marco.Ragazzi@ing.unitn.it

Dr. Ing. Dipl. Irina Aura Istrate  
Politehnica University of Bucharest  
Spl. Independentei 313, Bucharest 6, 060042, Romania  
Telefon +40 21 4029433  
Email ia\_istrate@yahoo.com

# Waste Producers' Duty of Care under European Community Law

Randy Michael Mott<sup>1</sup>

CHWMEG-EU, Warsaw, Poland

## Abstract

In a little-noticed case in 2008, the European Court of Justice held that waste producers have a duty to take reasonable precautions to assure proper disposal of their waste under the Waste Framework Directive. The Court, in effect, invalidated the laws of 15 Member States that purport to allow transfer of liability to third-party waste vendors. The same “polluter pays” language as to waste producers was re-enacted in the revised Directive and should be reflected in the latest transposition of the Directive in 2010 to meet the Court's ruling on what is mandatory community law.

## Keywords

waste producer liability, duty of care

## 1 Introduction

While the Environmental Liability Directive gained an enormous amount of public attention in Europe, an expansive interpretation of waste producers' obligations under the Waste Framework Directive by the European Court of Justice has largely gone unnoticed. See [Commune de Mesquer v Total France SA](#), ([link](#)) European Court of Justice (Case No. 188/07). The “polluter pays principal” has frequently been the basis for regulatory measures adopted by the European Parliament, but rarely has it been broadly interpreted to impose liability for third-party damages and clean-up costs. The [Total France](#) decision imposes a broad duty of care on waste producers that has survived in the revised Directive and supersedes the enacted statutes of fifteen Member States that have allowed some form of transfer of liability under waste management contracts. While the revised Waste Framework Directive apparently alters this equation for producers of products, *the same ECJ logic will apply to waste producers*, who remain under the “polluter pays” language in the new article 14. Although generally not recognized, the [ECJ has created a minimum mandatory standard of waste producer liability in the](#)

---

<sup>1</sup> The author is a consultant in Warsaw, Poland and the European coordinator for CHWMEG, the largest waste stewardship organization in the world. He practiced environmental law for 25 years in the United States and was involved in over 140 waste site cases. Mr. Mott has lived in Poland since 2000, teaches EU environmental law at Lazarski School of Law and Commerce and is the Polish national reporter for the European Environmental Law Institute (TMC Asser), the Hague.



EU that requires waste producers exercise reasonable care to prevent subsequent problems with wastes handled by third-parties.

## 2 Total France Decision

One of the earliest EC environmental directives was the Waste Framework Directive in 1975. See 75/442/EEC ([as amended](#)) (now revised [2008/98/EC](#)). The Waste Framework Directive contained Article 15 on liability for waste disposal:

*'In accordance with the "polluter pays" principle,<sup>2</sup> the cost of disposing of waste must be borne by: –the holder who has waste handled by a waste collector or by an undertaking as referred to in Article 9, and/or –the previous holders or the producer of the product from which the waste came.<sup>3</sup>*

Member States were given wide latitude by the European Commission in their transposition of this Directive in the very early years of EU environmental law. Most Member States took up a rule that allowed the waste producer to transfer liability along with the waste to a third-party, often with caveats that that party be licensed and/or that the waste be properly described.<sup>4</sup> See Mott, European Environmental Law, TMC Asser Institute, the Hague (2007) ["State of the Law in Europe on Generator Liability: Waste Ste-](#)

---

<sup>2</sup> The "polluter pays" principle is well-established in EU law from Article 174(2) of the European treaty. "In simple terms, this is the principle that the cost of measures to deal with pollution should be borne by the polluter who causes the pollution." Jans, EUROPEAN ENVIRONMENTAL LAW 3<sup>rd</sup> Edition (2008), p. 43.

<sup>3</sup> This has been amended in the revised Framework Directive approved in June 2008. Article 14 modified the language as follows: "1. *In accordance with the polluter-pays principle, the costs of waste management shall be borne by the original waste producer or by the current or previous waste holders. 2. Member States may decide that the costs of waste management are to be borne partly or wholly by the producer of the product from which the waste came and that the distributors of such product may share these costs.*" The obligatory liable parties seem to be limited now to the waste producer and subsequent holders, while product producers can be held responsible at the Member States' option. However, the entire analysis of how the "polluter pays" principle can reach a waste producer not in actual possession of the waste still is relevant. See further discussion herein.

<sup>4</sup> The Revised Waste Framework Directive must be transposed by 2010. It may trigger a fundamental re-evaluation of the older laws. "When the waste is transferred from the original producer or holder to one of the natural or legal persons referred to in paragraph 1 for preliminary treatment, the responsibility for carrying out a complete recovery or disposal operation shall not be discharged as a general rule. Without prejudice to Regulation (EC) No 1013/2006, Member States may specify the conditions of responsibility and decide in which cases the original producer is to retain responsibility for the whole treatment chain or in which cases the responsibility of the producer and the holder can be shared or delegated among the actors of the treatment chain." Article 15(2) [2008/98/EC](#).

[wardship in a Complex System.](#)” In a Danish case, where their legislation followed this approach, the courts ruled that it only transferred liability of the third-party acted within the scope of the license for handling the waste.<sup>5</sup> Other Member States required that the waste producer exercise a degree of care in selection of the third-party contractor. Some have strict liability under national law. Most seem to clearly take the view that they had discretion to provide for the transfer of liability under some defined conditions.<sup>6</sup> Against this context, the European Court of Justice had the occasion to interpret when a producer of a product could be considered a “waste holder” and under what circumstances could the liability of the holder be transferred to third-parties.

The ECJ describes the basic facts of the case: “*On 12 December 1999 the oil tanker Erika, flying the Maltese flag and chartered by Total International Ltd, sank about 35 nautical miles south-west of the Pointe de Penmarc’h (Finistère, France), spilling part of her cargo and oil from her bunkers at sea and causing pollution of the Atlantic coast of France.*” Judgment of the Court, [Commune de Mesquer v Total France SA](#), ([link](#)) (ECJ Case No. 188/07). The supplier of the oil was Total France: “*Total France SA, sold the heavy fuel oil to Total International Ltd, which chartered the vessel Erika to carry it from Dunkirk (France) to Milazzo (Italy).*” *Id.* The local town where the spill occurred sued the French companies involved in the transaction and spill.

The French courts rejected the town's claim, finding “*that the heavy fuel oil did not in this case constitute waste but was a combustible material for energy production manufactured for a specific use.*” *Id.* It further “*accepted that the heavy fuel oil thus spilled and mixed with water and sand formed waste, but nevertheless considered that there was no provision under which the Total companies could be held liable, since they could not be regarded as producers or holders of that waste.*” *Id.* The final French court in-

---

<sup>5</sup> “A producer of hazardous waste may be held liable for unauthorised disposal of waste by a transporter to whom the producer passed on the waste. A company, Horn Belysning, was convinced by a waste transporter that it had an arrangement with a licensed waste undertaker. The transporter dumped the waste illegally and was prosecuted. The court found Horn Belysning liable for clean-up costs and disposal expenses holding that it had the power to ensure the waste reached an authorised undertaker and could not escape liability by using a waste transporter (re. Horn Belysning, unpublished, Western High Court, 6 division 10th June 1993)(*emphasis added*).” McKenna & Co. (now Cameron McKenna), [Study of Civil Liability Systems for Remedying Environmental Damage, FINAL REPORT](#) to the European Commission (December 1995) discussing [In re Horn Belysning](#) (unpubl. Western High Court, 6 Division, June 10, 1993). See Larsson, [The Law of Environmental Damage: Liability and Reparation](#) (Martinus Nijhoff Publishers 1999) p. 328.

<sup>6</sup> Such national laws cannot act to undermine EU schemes that retain waste producer liability in certain incidences, such as the Environmental Liability Directive and the IPPC Directive, which have both been used for this purpose.

volved (the Court of Cassation) stayed the matter and requested an interpretation of the Waste Framework Directive from the European Court of Justice.

After wrestling with the issue of liability limits under the international oil spill convention, the ECJ identified three issues in the case that arose under community law:

*“1. Can heavy fuel oil, as the product of a refining process, meeting the user’s specifications and intended by the producer to be sold as a combustible fuel, and referred to in [Directive 68/414] be treated as waste within the meaning of Article 1 of [Directive 75/442] as ... codified by [Directive 2006/12]?”*

*2. Does a cargo of heavy fuel oil, transported by a ship and accidentally spilled into the sea, constitute – either in itself or on account of being mixed with water and sediment – waste falling within category Q4 in Annex I to [Directive 2006/12]?”*

*3. If the first question is answered in the negative and the second in the affirmative, can the producer of the heavy fuel oil (Total raffinage [distribution]) and/or the seller and carrier (Total International Ltd) be regarded as the producer and/or holder of waste within the meaning of Article 1(b) and (c) of [Directive 2006/12] and for the purposes of applying Article 15 of that directive, even though at the time of the accident which transformed it into waste the product was being transported by a third party?” Supra, para. 28.<sup>7</sup>*

On the first question, whether the oil was a waste (before it leaked), the court concluded: *“...a substance such as that at issue in the main proceedings, namely heavy fuel oil sold as a combustible fuel, does not constitute waste within the meaning of Directive 75/442, where it is exploited or marketed on economically advantageous terms and is capable of actually being used as a fuel without requiring prior processing.” Id.<sup>8</sup>*

---

<sup>7</sup> American lawyers will be interested in the Court’s handling of the issue of mootness, which is very different from U.S. jurisprudence: “It may be seen from the documents in the case that the Commune de Mesquer has indeed received payments from the Fund, made following the claim for compensation it brought against inter alia the owner of the Erika and the Fund. Those payments were the subject of settlements by which the municipality expressly agreed not to bring any actions or proceedings, on pain of having to repay the sums paid. It is apparent that the Cour de cassation had that information before it, but none the less did not consider that the dispute in the main proceedings had ceased or that the Commune de Mesquer had lost its legal interest in bringing proceedings, and did not decide not to refer its questions to the Court for a preliminary ruling. In those circumstances the questions put by the Cour de cassation must be answered.” Supra, para. 32-34.

<sup>8</sup> One troubling part of the ECJ’s traditional analysis of what is a waste is illogical, i.e. whether it needs to be processed further. All raw materials need to be processed further and are never in real terms considered “wastes.” The sole issue in this context is whether there is “an intent to discard.” The economics of further processing is only relevant as indicia of intent.

On the second question, “*whether heavy fuel oil that is accidentally spilled into the sea following a shipwreck must in such circumstances be classified as waste within the meaning of category Q4 in Annex I to Directive 75/442,*” the ECJ followed its precedent which really left little doubt as to the answer. Rejecting the UK argument that heavy oil spilled at sea was “*covered exclusively by the Liability Convention and the Fund Convention, so that Directive 75/442 does not apply in such circumstances.*” and noting that the oil washed ashore on a Member State's territory,<sup>9</sup> the Court reiterated that the spilled oil was “waste,” citing Case C-1/03 *Van de Walle and Others* [2004] ECR I-7613, paragraph 47.<sup>10</sup>

The third question is the critical one in the case: “*whether, in the event of the sinking of an oil tanker, the producer of the heavy fuel oil spilled at sea and/or the seller of the fuel and charterer of the ship carrying the fuel may be required to bear the cost of disposing of the waste thus generated, even though the substance spilled at sea was transported by a third party.*” *Id.* (emphasis added).

At the outset, we should note that French law already covered the “producer of waste” given to third parties. The 1975 French statute involved in *Total France* had been considered adequate to create strict liability for “waste producers”: “[T]he 1975 waste law ... allows waste producers to be held liable if they have consigned waste to a disposer improperly.” Clarke, “Update Comparative Legal Study,” European Commission Study on

---

<sup>9</sup> “...contrary to the arguments put forward by the Total companies at the hearing, the Community is not bound by the Liability Convention or the Fund Convention. In the first place, the Community has not acceded to those international instruments and, in the second place, it cannot be regarded as having taken the place of its Member States, if only because not all of them are parties to those conventions (see, by analogy, Case C-379/92 *Peralta* [1994] ECR I-3453, paragraph 16, and Case C-308/06 *Intertanko and Others* [2008] ECR I-0000, paragraph 47), or as being indirectly bound by those conventions as a result of Article 235 of the United Nations Convention on the Law of the Sea, signed at Montego Bay on 10 December 1982, which entered into force on 16 November 1994 and was approved by Council Decision 98/392/EC of 23 March 1998 (OJ 1998 L 179, p. 1), paragraph 3 of which confines itself, as the French Government pointed out at the hearing, to establishing a general obligation of cooperation between the parties to the convention. Furthermore, as regards Decision 2004/246 authorising the Member States to sign, ratify or accede to, in the interest of the Community, the Protocol of 2003 to the Fund Convention, it suffices to state that that decision and the Protocol of 1993 cannot apply to the facts at issue in the main proceedings.” *Supra*, para. 85-86. For a discussion of the implications for international oil spill law, see Norton Rose analysis. [\[link\]](#)

<sup>10</sup> Again, whether it could be further processed seems irrelevant, especially since it was discarded and the definition in the Directive provides that a waste is “*any substance or object in the categories set out in Annex I which the holder discards or intends or is required to discard.*” Waste Framework Directive 2006/12/EC, Article 1(1)(a). Its economic value through additional processing is only relevant as evidence of intent to discard and becomes irrelevant if it is, in fact, discarded.

Environmental Liability (2001). So the issue before the ECJ upon which the Court of Cassation requested an opinion was whether and when the EU Directive required that the **producer of a product** that became a waste was liable.

*“Under Law 76/663, the operator (exploitant) and, to a lesser extent, the “détenteur” of the listed site are likely to be liable, while under Law 75/633 the producer and the “détenteur” of waste are most likely to incur liability. “Détenteur” has a broad definition and it can mean the owner, the occupier, the receiver in bankruptcy or, in the case of waste, it can be any intermediary...”<sup>11</sup>*

Total argued to the court that *“Article 15 of Directive 75/442 does not apply to the producer of the heavy fuel oil or to the seller of the oil and charterer of the ship carrying that substance, in that, at the time of the accident which converted the substance into waste, it was being carried by a third party.”* *Id.* (emphasis added). The European Commission and some of the national governments briefing the case argued:

*“...that the producer of the heavy fuel oil and/or the seller of the oil and charterer of the ship carrying that substance may be regarded as producers and/or holders of the waste resulting from the spillage at sea of that substance only if the shipwreck that converted the cargo of heavy fuel oil into waste was attributable to various actions capable of making them liable. The Commission adds, however, that the producer of a product such as heavy fuel oil may not, merely because of that activity, be regarded as a ‘producer’ and/or ‘holder’ within the meaning of Article 1(b) and (c) of Directive 75/442 of the waste generated by that product on the occasion of an accident during transport. He is none the less obliged under the second indent of Article 15 of that directive to bear the cost of disposing of the waste, in his capacity as ‘producer of the product from which the waste came’.”*

---

<sup>11</sup> McKenna & Co. (now Cameron McKenna), [Study of Civil Liability Systems for Remedying Environmental Damage, FINAL REPORT](#) to the European Commission (December 1995), p. 191: *“Article 11 of Law 75/633 on waste provides that any person who disposes of or causes to be disposed of certain categories of waste and all operators of listed waste disposal installations can be held jointly liable for damage caused by the waste. This therefore imposes liability across the chain of waste disposal from the producer to the disposer.”* As early as 1995, the McKenna study for the European Commission noted that: *“...this [French] case law tends to show an evolution towards a strict liability regime applicable to the [waste] producer. This case law ...[has been] criticised on the basis that it applied the “deep pocket” principle.”* *Id.* Nevertheless, the trend has continued and there is little doubt today that the French waste law covers waste producers. See Frédéric Bourgoin, “Soil Protection in French Environmental Law,” [Journal for European Environmental & Planning Law](#) (2006) ([link](#)).



The court dealt with the argument by starting with a reminder that in Van Der Walle it had already found that a “waste holder” could be a party not in actual possession of the waste.

*“It follows from those provisions [Article 15 cited above] that Directive 75/442 distinguishes the actual recovery or disposal operations, which it makes the responsibility of any ‘holder of waste’, whether producer or possessor, from the financial burden of those operations, which, in accordance with the ‘polluter pays’ principle, it imposes on the persons who cause the waste, whether they are holders or former holders of the waste or even producers of the product from which the waste came (Van de Walle, paragraph 58)...The application of the ‘polluter pays’ principle within the meaning of the second sentence of the first subparagraph of Article 174(2) EC and Article 15 of Directive 75/442 would be frustrated if such persons involved in causing waste escaped their financial obligations as provided for by that directive, even though the origin of the hydrocarbons which were spilled at sea, albeit unintentionally, ” id. para. 72 (emphasis added).*

The Court cites Article 15 which specifically includes “*the producer of the product from which the waste came.*” Applying the “polluter pays” principle that is specifically incorporated into the Directive, the Court focuses the inquiry on whether the producer of the product in effect was a “polluter”<sup>12</sup>.

*“Article 15 of Directive 75/442 provides that certain categories of persons, in this case the ‘previous holders’ or the ‘producer of the product from which the waste came’, may, in accordance with the ‘polluter pays’ principle, be responsible for bearing the cost of disposing of waste. That financial obligation is thus imposed on them because of their contribution to the creation of the waste and, in certain cases, to the consequent risk of pollution.” Id. para. 77.*

The opinion then describes the test for when a producer of the product might be considered by the trial court to be a contributing cause of the waste' release:

*“...the national court may therefore consider that the seller of the hydrocarbons and charterer of the ship carrying them has ‘produced’ waste, if that court, in the light of the elements which it alone is in a position to assess, reaches the conclu-*

---

<sup>12</sup> Of course, this does not mean that other parties more directly involved in the spill are excluded from joint liability: “...it must be held that the owner of the ship carrying those hydrocarbons is in fact in possession of them immediately before they become waste. In those circumstances, the ship owner may thus be regarded as having produced that waste within the meaning of Article 1(b) of Directive 75/442, and on that basis be categorised as a ‘holder’ within the meaning of Article 1(c) of that directive.” Judgment, supra, para. 74.

*sion that that seller-charterer contributed to the risk that the pollution caused by the shipwreck would occur, in particular if he failed to take measures to prevent such an incident, such as measures concerning the choice of ship.” Id. Para. 78 (emphasis added).*

Significantly, the ECJ found that this interpretation of Article 15 of the Waste Framework Directive is binding on Member States:

*“...in accordance with Article 249 EC, while the Member States as the addressees of Directive 75/442 have the choice of form and methods, they are bound as to the result to be achieved in terms of financial liability for the cost of disposing of waste. They are therefore obliged to ensure that their national law allows that cost to be allocated either to the previous holders or to the producer of the product from which the waste came.” Id. para. 80 (emphasis added).*

Does this mean that Member State's can provide for liability only to the intermediaries and let the producer of the product that become waste walk? The ECJ says no:

*“...if it happens that the cost of disposal of the waste produced by an accidental spillage of hydrocarbons at sea is not borne by that fund, or cannot be borne because the ceiling for compensation for that accident has been reached, and that, in accordance with the limitations and/or exemptions of liability laid down, the national law of a Member State, including the law derived from international agreements, prevents that cost from being borne by the ship owner and/or the charterer, even though they are to be regarded as ‘holders’ within the meaning of Article 1(c) of Directive 75/442, such a national law will then, in order to ensure that Article 15 of that directive is correctly transposed, have to make provision for that cost to be borne by the producer of the product from which the waste thus spread came. In accordance with the ‘polluter pays’ principle, however, such a producer cannot be liable to bear that cost unless he has contributed by his conduct to the risk that the pollution caused by the shipwreck will occur.” Id. para. 82 (emphasis added).<sup>13</sup> (emphasis added).*

---

<sup>13</sup> This is an area where the ECJ asserts the primacy of community law over national discretion: *“The obligation of a Member State to take all the measures necessary to achieve the result prescribed by a directive is a binding obligation imposed by the third paragraph of Article 249 EC and by the directive itself. That duty to take all appropriate measures, whether general or particular, is binding on all the authorities of the Member States including, for matters within their jurisdiction, the courts (see Case C-106/89 Marleasing [1990] ECR I-4135, paragraph 8, and Inter-Environnement Wallonie, paragraph 40).” Id. para. 83 (emphasis added).*



While commentary on the Total France case has been robust as to the international oil spill implications, few observers have noted that this logic under the Waste Directive is applicable to all waste producers within the Directive's broad scope. Accordingly, a waste producer may be held liable if the national law elects to make him a primarily liable party or if the third-parties lack the means to pay the damages or cleanup where the producer "contributed to the risk that the pollution caused by the ...[release into the environment] would occur, in particular if he failed to take measures to prevent such an incident..." Id. para. 89. Member States do not have the option to narrow this liability if participation by the waste producer is financially necessary:

*"...a national law will then, in order to ensure that Article 15 of that directive is correctly transposed, have to make provision for that cost to be borne by the producer of the product from which the waste thus spread came. In accordance with the 'polluter pays' principle, however, such a producer cannot be liable to bear that cost unless he has contributed by his conduct to the risk that the pollution..."* Id. para. 89 (emphasis added)(only product producers were removed by the WFD Revision)

### 3 Analysis

The ruling of the European Court of Justice in Total France has generally been unappreciated in Europe. Commentary in the *European Law Reporter* was one of the few sources to pick up the implications: "...how will one be able to prove that a producer contributed to the supervening risk of pollution if he ... does not have any method of controlling the substances which he produced?" 12 *ELR* 2008 at 409. The flip side is how does the enforcer prove that the producer contributed to the risk?

The underlying issue is what standard of care will apply to producers of products and raw materials which may become improperly discarded wastes through the actions of third-parties. The ECJ suggested in its opinion that the oil company should have inspected the ship involved and that this would have prevented the incident. Even if it did not prevent the accident, i.e. the defective condition was latent or not readily ascertained, would an inspection have been sufficient? Since the standard used by the Court is fault, albeit one of omission, it can be argued that reasonable care would be sufficient. Support for this view comes from the "polluter pays" precedent before the ECJ. Earlier decisions have indicated that a legal measure must avoid putting burdens on persons and undertakings for the elimination of pollution to which they have not contributed. Case C-293/97 *Standley* [1999] ECR I-2603.

Some reasonable precautions could include site inspections, inventory control, explicit safety instructions, and contract provisions regarding proper handling. Two examples may illustrate measures that will likely create good defenses for producers. The first is the European Chemical Industry Council "Responsible Care" program which provides safety procedures, labeling, and actual site inspections to third-party handlers of products and materials. An example illustrates the level of detail involved [\[link\]](#). Specially-trained auditors conduct reviews of transportation facilities for the industry participants. The second is CHWMEG, which provides a similar service for members, by reviewing third-party recycling, recovery and disposal contractors and facilities. CHWMEG membership extends internationally and across industry sectors, including chemical, oil, electronics, pharmaceutical, aerospace, and other businesses. CHWMEG would be relevant, for example, to producers of electronic and electrical equipment that is shipped for reuse, recovery or recycling. Cost-sharing of the reviews allows the facility reviews to be done for very moderate fees.

## 4 Impact of Revised Directive

While the Revised Directive removes product producers from the Total France rule, it does not affect waste producers.

*"Member States may decide, in accordance with Article 8, that the responsibility for arranging waste management is to be borne partly or wholly by the producer of the product from which the waste came and that distributors of such product may share this responsibility." Article 15(3).*

Additional disputes over the provisions in the revised Directive seem to be inevitable.

The question of the implications of Total Oil on waste producers looms large, since "waste producers" are singled out in the revised Directive. New Article 14 repeats the earlier language applied in Total Oil citing *"the original waste producer or .. "the current or previous waste holders"* under the polluter pays language. Using the ECJ's reasoning, then, a waste producer would not have to be in physical possession to be liable and failure to provide for this prospect would be an inadequate transposition of community law. The ECJ's rationale would require that a waste producer, who contributed to the risk of improper handling, remain liable even if not longer in physical possession. This is inconsistent with the existing transpositions of at least 15 of the 27 Member States (which allow transfer of liability).

Member States must now revisit these issues in a new transposition due by the end of 2010. The prospect of enlarged waste producer liability is heightened by the revised Waste Framework Directive, 2008/98/EC [\[link\]](#) which has still encourages the retention of waste producer liability: *"In accordance with the polluter-pays principle, the costs of*

waste management shall be borne by the original waste producer or by the current or previous waste holders.” Article 14(1). The revised Directive adds a preliminary finding that:

*“The polluter-pays principle is a guiding principle at European and international levels. The waste producer and the waste holder should manage the waste in a way that guarantees a high level of protection of the environment and human health.”* Directive 2008/98/EC, Clause 26.

It further provides an explicit duty on waste producers:

*“Member States shall take the necessary measures to ensure that any original waste producer or other holder carries out the treatment of waste himself or has the treatment handled by a dealer or an establishment or undertaking which carries out waste treatment operations or arranged by a private or public waste collector in accordance with Articles 4 and 13 “*

Using the polluter pays principle, the standard of care of a waste producer will inevitably be at least as great as the standard applied by the ECJ to the product producer. A “waste producer's” closer involvement with the material when it is already a waste and the foreseeability of improper disposal suggest an implicit standard of care be applied to reduce the subsequent risk. The assumption that a national law allowing liability transfer for the waste producer to occur along with physical transfer to a third-party contractor seems to be quite inconsistent with the Court's reasoning in Total France. The issue will undoubtedly be tested in Member State's national court systems in the coming years.

So the minimum European community legal standard for waste producers is implicitly the duty to take reasonable precautions in handling waste, a duty that cannot be completely delegated. In light of the ECJ construction of the same language that contained in new Article 14, it appears that Member States may not have complete discretion to provide for the complete transfer of liability to third-parties, as the waste producer arguably has a duty to take precautions as to third-party actions. This will also be construed along with new language in the Directive in Article 15(2):

*“ When the waste is transferred from the original producer or holder to one of the natural or legal persons referred to in paragraph 1 for preliminary treatment, the responsibility for carrying out a complete recovery or disposal operation shall not be discharged as a general rule.”* [2008/98/EC](#).

The Revised Waste Framework Directive, approved by the European Parliament just seven days before the ECJ decision in Total Oil, will cause these issues to be revisited in all Member States in 2010 as they grapple with the transposition. Given the history of

the European court's expansive reading of waste holder liability in Van der Walle and Total Oil there is clearly an element of legal risk to waste producers under the community-wide scheme. There are, of course, separate European predicates for waste producer liability under the IPPC Directive and Environmental Liability Directive as well as under national laws in each Member State.

The due care approach to waste producer liability, of course, differs fundamentally from the strict liability regime of the United States and some European jurisdictions. Frankly, a due care approach makes the review and audit of third-party waste and recycling contractors more cost-effective than a strict liability scheme. Under due care, the end disposal of waste can still be problematic, but a waste producer may escape liability by demonstrating due care. Under a strict liability scheme, the due care efforts must be effective to forestall the improper disposal or handling. Similarly, the European jurisdictions that have provided for transfer of liability to licensed third-parties have seen courts limit this defense to actions taken by the third-parties consistent with their license. In these circumstances, a review or audit of the third-party to assure that their actions in handling a producer's waste are within their permit conditions can be a very cost-effective defense to subsequent claims. Despite the legal complexities of European situation, there remains a very high value for "supply chain" audits in the area of waste. Collective, cost-sharing arrangements for such reviews provide a sensible way to handle an increasingly vexing set of problems.

## 5 Literature

European Union	2008	Revised Waste Framework Directive, <a href="#">2008/98/EC</a>
European Court of Justice	2008	<a href="#">Commune de Mesquer v Total France SA</a> , (Case No. 188/07)[2008].
European Court of Justice	1999	<a href="#">Standley</a> (Case C-293/97)[1999] ECR I-2603.
Danish Western High Court	1993	<a href="#">In re Horn Belysning</a> (unpubl. Western High Court, 6 Division, June 10, 1993).
Jans, Jan	2008	EUROPEAN ENVIRONMENTAL LAW 3 <sup>rd</sup> Ed.
Larsson	1999	<a href="#">The Law of Environmental Damage: Liability and Reparation</a> (Martinus Nijhoff Publishers).
Mott, Randy	2007	<a href="#">"State of the Law in Europe on Generator Liability: Waste Stewardship in a Complex System," European Environmental Law, TMC Asser Institute, the Hague (2007)</a>

McKenna & Co.	1995	<a href="#"><u>Study of Civil Liability Systems for Remedying Environmental Damage, FINAL REPORT</u></a> (European Commission, Dec. 1995).
Frédéric Bourgoïn	2006	“Soil Protection in French Environmental Law,” <a href="#"><u>Journal for European Environmental &amp; Planning Law</u></a> (2006)
Clarke, Richard	2001	“Update Comparative Legal Study,” European Commission Study on Environmental Liability (2001).

**Author's address**

Randy Michael Mott  
CHWMEG Inc.  
ul. Emilii Plater 53, 11<sup>th</sup> floor  
00-113 Warsaw Poland  
Telephone +48 22 528 6700  
Email: [europa@chwmeg.org](mailto:europa@chwmeg.org)  
Website: [www.chwmeg.org](http://www.chwmeg.org)

# Optimization model of integrated MSW management

Lubomir Nondak

Integra Consulting Services Ltd., Praha, Czech Republic

## Abstract

The communication presents a conceptual model proposed for optimal municipal solid waste allocation. The current version of model optimizes cumulative emission of greenhouse gases. Model takes advantages of algebraic modelling languages, which enables to develop models in a scalable manner independent of the database used. Continuous flows of four municipal solid waste components (bio-waste, materials, refuse derived fuel and inert fraction), which take place between sets of sources and installations are quantified and converted to the greenhouse gases emission. Uncertainties of inputs, especially varying composition of MSW, have been modelled by Monte-Carlo experiments.

## Key words

Integrated waste management, allocation model, greenhouse gas emissions, linear programming

## 1 Introduction

Since beginning of 90s, various municipal solid waste (MSW) management models have been designed mostly utilizing life cycle analysis (LCA). Majority of such models are static and deterministic ones which means that uncertainty of inputs (e.g. quantities and composition of MSW or emission factors) is not taken into account. The static LCA models also do not enable to optimise the allocation of MSW between spatially distributed sources (municipalities) and installations (separators, composting facilities, incinerators, landfills etc.). The limitations of LCA for waste management planning and policy making has been discussed by EKVALL ET AL. (2004). However LCA is a basic method to assess alternative scenarios as demonstrated by DE FEO AND MALVANO (2009). In this respect further modifications of LCA such as economic input-output life-cycle assessment (EIO-LCA) results in valuable modelling tools applicable at national level as shown recently (HENDRICKSON, LAVE AND MATTHEWS, 2006; DISTEFANO AND BELENKY, 2009).

Major drawback of regional- or local-scale LCA relates to its inability to characterise spatial distribution of impacts. Local impacts like transport noise, groundwater pollution or PM10 emitted by transport vehicles are more important in local decision making processes such as EIA than acidification or global warming. In such cases LCA should be combined with other techniques such as noise or dispersion modelling. Especially impact of increasing waste transport draws attention to logistic models which are combined with LCA (SALHOFER, SCHNEIDER AND OBERSTEINER, 2007). However the goal of

transport modelling is not only to assess traffic impacts but to look for optimal allocation of MSW or other wastes between sources and installations, which may have individual spectrum of emission factors or material/energy efficiencies. One may look at the system composed of MSW sources and receiving installations in a holistic view and look for various allocation optima (minimum emissions, maximum energy efficiency etc.).

Several different allocation models using linear programming, integer programming, mixed-integer programming or non-linear programming had been reported. COSTI ET AL. have designated a mixed integer non-linear programming decision support model for optimization of integrated waste management (IWM) system composed of separators, refuse derived fuel (RDF) production plants, incinerators with energy recovery, processing of biodegradable wastes and sanitary landfills. Genova region (Italy) has been used for their case study. The same area has been modelled by FIORUCCI ET AL. using an integer non-linear programming model. Goal of the modelling experiments has been to estimate optimal structure of landfills and treatment plans in respect to the composition of MSW.

We have used the technique of linear programming (LP) to design an optimization model for minimization of greenhouse gas emissions (carbon dioxide, methane and nitrous oxide) related to a set of spatially distributed MSW sources (municipalities) and installations with various disposal capacities and emission factors. Because of the LP solver used the model is scalable enough to be used on a regional/national scale and the set of installation categories can be expanded. Uncertainties of inputs, especially varying composition of MSW, have been modelled by Monte-Carlo experiments. The model is relatively simple and currently optimizes the allocation of four MSW components: biodegradable waste, recyclable materials, RDF and inert fraction.

## **2 Optimization problem and basic model characteristics**

In this case, minimum aggregated emission of GHGs (expressed as CO<sub>2</sub> eq) in a system composed of MSW sources and receiving installations such as separators, composting facilities, bioreactors, material reprocessing facilities, energy sources and landfills are looked for. Sources and facilities are located in a 2-dimensional map where MSW and materials derived from (separated biodegradable fraction, recyclable materials, refuse derived fuel and inert waste) are transported between individual objects (municipalities, installations) defined by x, y - coordinates, generation rates and capacities.

Basic characteristics of the model can be summarized:



1. Single parameter optimization (e.g. cumulative emissions, overall energy consumption or efficiency, transport intensity, overall costs) by a commercially available LP solver,
2. Model is based upon a rational behaviour of collectors and waste transporters to minimize the transport distances/costs. It does not apply to extreme cases of MSW transport referred by SALHOFER, SCHNEIDER AND OBERSTEINER (2007) when wastes were transported e.g. from south Italy to foreign incinerators.
3. Flow of MSW and material components during the time period considered (e.g. year) is continuous, no accumulation occurs,
4. Model is scalable to encompass large number of sources and installations. Its practical size is limited by data availability and the programming environment used (MS Excel and an available version of commercial LP solver LINGO),
5. Sources are characterised by data sets including GPS coordinates, population size, prevailing character of municipality (apartment houses, family houses or villages), MSW composition and generation rates, efficiency of MSW separation at source etc. Emissions related to collection of MSW and its transport are related to the character of municipality and capacity of the collection cars used,
6. Installations are characterised by technology used, emission factors and disposal capacities,
7. As a first approximation, Euclid distances calculated from GPS coordinates are modified by an average tortuosity estimated for the geographic area studied. Euclid distance can be substituted by road distance if necessary.
8. All adjustable parameters are either available (measurements, literature) or substitutable by expert judgment.
9. Propagation of uncertainty related to inputs (e.g. generation rates, compositions, emission factors and collection distances) is modelled using a Monte-Carlo technique. At this stage, normal distribution functions are assumed for inputs. Stochastic independence between inputs is assumed at this stage of model development, which means that the value taken by one input parameter does not influence the probability of occurrence of the other input parameters.
10. Testing procedures have been set down during the development of the LP model.

### 3 Concise description of the model

The optimization model consists of six sets:

- i MSW sources
- j waste separators
- k bioreactors and/or composting facilities
- l material processing units
- m energy recovery units
- n landfills

Overall material flows between individual parts of the IWM system are demonstrated in Figure 1.

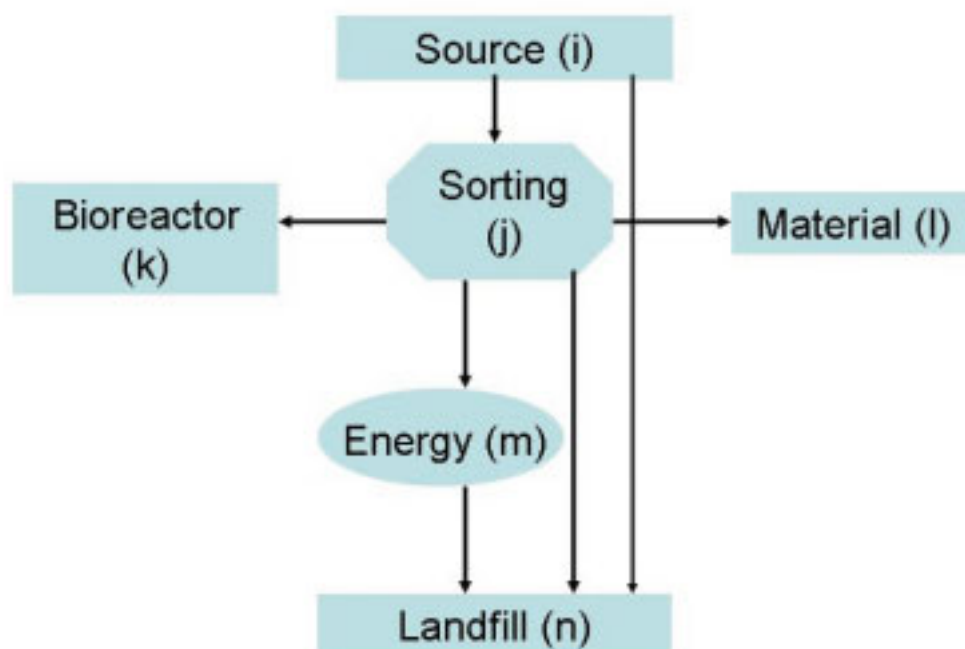

*Figure 1 Overall diagram of material flows modelled*

In this case, MSW consists of four components: biodegradable wastes (B), recyclable materials (M), refuse derived fuel (F) and inert waste (I). The individual waste components flow from set of sources into the set of waste separators and installations or they are directed to set of landfills (Figure 1). Arrows represent direction of flows along the allocation routes. Flows of individual components (B, M, F and I) have been derived from the overall flow diagram (Figure 1).

Emissions of GHGs (expressed as CO<sub>2</sub> eq) occur during transport and processing of wastes in individual installations as they depend upon technology and processed quantities of B, M, F and I. For example emissions,  $e$ , related to transport and separation of input quantity,  $q$ , of waste in a separator can be expressed as

$$e = q(\varepsilon_t l / C_{veh} + \varepsilon_p)$$

where  $\varepsilon_t$  is a transport emission factor (as CO<sub>2</sub> emissions per km),  $l$  is transport distance,  $C_{veh}$  is the capacity of transport vehicle and  $\varepsilon_p$  is an overall process emission factor for the given separator. For all  $j$  separators one can therefore calculate aggregated emissions as

$$E_{separ} = \sum_j q_{i,j} (\varepsilon_t l_{ij} / C_{veh(i,j)} + \varepsilon_p) \quad \forall routes, separators$$

Similar expressions are derived for other installations. Objective function,  $E$  (*min*), is a sum of aggregated emissions related to all installations, routes and allocated quantities MSW including its individual components (B, M, F and I):

$$E \text{ (min)} = E_{separ} + E_{mat} + E_{bio} + E_{fuel} + E_{land}$$

Installed annual capacities  $C_{separ}$ ,  $C_{bio}$ ,  $C_{mat}$ ,  $C_{energy}$ ,  $C_{land}$  are used as constraints. For example, for all  $j$  separators the following constraint holds:

$$C_{separ} \leq \sum_i q_{Bi} + \sum_i q_{Mi} + \sum_i q_{Fi} + \sum_i q_{Ii} \quad \forall sources$$

Analogically, input/output mass balances of individual installations represent another set of constraints, e.g. for component B treated in composting facilities or disposed at landfills

$$\sum_i q_{Bi} = \sum_j q_{Bj} + \sum_n q_{Bn}$$

$$\sum_j (\sigma_B \cdot q_{Bj}) = \sum_k q_{Bk}$$

$$\sum_j ((1 - \sigma_B) \cdot q_{Bj}) = \sum_k q_{Bn}$$

Separation efficiencies,  $\sigma$ , are adjusted for the separated component and given installation in interval (0, 1). Constraining mass balances are set down for other components in the same way.

## 4 Implementation of the model

Model has been implemented in LINGO algebraic modelling language and solved by means of a linear programming LINGO solver (Lindo Systems Inc., USA). As a comprehensive modelling language LINGO allows the transcription of the above balance equations and constraints closer to their mathematical forms than other programming languages. LINGO enables to programme algebraic operations over basic and derived sets (sources, installations, routes) which make the code comprehensive and condensed. For example, a series of similar constraints can be expressed as a single statement. The advantages of algebraic modelling languages (e.g. GAMS, AMPL, LINGO, NOP or Numerica) have been described by Schichl (2003).

After drawing flow diagrams (Figure 1) for individual waste components, a pseudo-code has been drafted to describe the content of basic blocks of the model (objective function, mass balances, constraints, sets and derived sets, data transfer). LINGO allows relatively long names for variables, which makes code building followed by inspections is easier. For example the set of capacity constraint for  $j$  separators (over B, M, F and I) is written as:

```
@FOR (MBT (J) :
  @SUM (ROUTE_SOURCE_MBT (I, J) : SF_MBT_COMP * XB (I) * Q_SOURCE_MBT (I, J) ) =
  @SUM (ROUTE_MBT_COMP (J, K) : Q_MBT_COMP (J, K) ) );

@FOR (MBT (J) :
  @SUM (ROUTE_SOURCE_MBT (I, J) : SF_MBT_MAT * XM (I) * Q_SOURCE_MBT (I, J) ) =
  @SUM (ROUTE_MBT_MAT (J, L) : Q_MBT_MAT (J, L) ) );

@FOR (MBT (J) :
  @SUM (ROUTE_SOURCE_MBT (I, J) : SF_MBT_ENERG * XF (I) * Q_SOURCE_MBT (I, J) ) =
  @SUM (ROUTE_MBT_ENERG (J, M) : Q_MBT_ENERG (J, M) ) );

@FOR (MBT (J) :
  @SUM (ROUTE_SOURCE_MBT (I, J) : (1-SF_MBT_MAT) * XM (I) * Q_SOURCE_MBT (I, J) +
  (1-SF_MBT_COMP) * XB (I) * Q_SOURCE_MBT (I, J) +
  (1-SF_MBT_ENERG) * XF (I) * Q_SOURCE_MBT (I, J) +
  XI (I) * Q_SOURCE_MBT (I, J) ) =
  @SUM (ROUTE_MBT_LAND (J, L) : Q_MBT_LAND (J, L) ) );
```

The model consists of two modules:

1. Optimization program in LINGO and
2. MS Excel database with quantities  $Q$  of MSW and amounts of B, M, F and I generated by individual sources, installation capacities, emission factors and separation factors of the installations. Sets of transport matrices contain distances  $l$ .

The transfer of data from the MS Excel database uses OLE (Object Linking and Embedding), which is a Microsoft's standard. OLE is used to transfer results of optimization into the MS Excel file (separate sheet or file). Besides value of the objective function,

the set of allocation matrices is generated. The matrices indicate the quantities of waste allocated along the individual routes from sources to separators/landfills and between installations (separators, bioreactors, material processing units, energy units and landfills), see Figure 1. The optimization model is independent of the size and content of the database (number of sources and installations). It is therefore possible to model scenarios prepared as individual MS Excel files, which makes the archiving of input data and modelling results quite easy.

#### 4.1 Model testing

Testing is an integral part of software development that needs to be carried out in parallel with computer program building (McCONNELL, 2004). Testing datasets have been therefore prepared during design and coding. Tests are based upon mass balance for individual components (B, M, F and I). A simple testing database (6 sources, 4 separators, 4 landfills, 2 bioreactors, 2 material processing units, 2 incinerators) has been used as a first testing tool. Simple allocation problems (“toy problems”, see Schichl, 2003) such as allocation of several mass units have been recalculated manually.

Next database has been prepared for “real life” district MSW disposal (real map, 110 municipalities, 4 landfills). The set of municipalities and installations has been taken from a regional MSW management plan. At present, the system is being currently modified and new installations are introduced into the system (anaerobic digester, composting facility, separator with RDF production and incinerator) as several scenarios. Emission factors and MSW composition are taken from a literature review.

Matrix of transport distances as an input is constructed in the first step as Euclidean distances multiplied with tortuosity ( $1.25 \pm 0.10$ ), which has been estimated from a sample of 3 x 25 roads (distances from 10 to 50 km) located in 3 different regions (South Bohemia, lowlands of Elbe River and mountainous landscape of Česko-Moravská Vysočina). Then allocation matrices (mass flows between objects) are compared with the real routes and the Euclidean distances are substituted in second modelling step by real distances (road map) for the routes used by the major sources. Unused or marginal routes can be characterised by Euclidean approximation.

An advanced testing database with 110 sources contains a random number generator (normal or rectangular distributions) which allows a random modelling of the proportions of B, M, F and I in MSW generated and therefore also random modelling of the total quantity of MSW generated by individual sources. Those experiments give information on cumulative distribution function of modelled output: total GHGs emissions (means and standard deviations estimated from series of modelling experiments) related to

various uncertainty of MSW input. This gives at least a rough idea on propagation of uncertainty. More sophisticated approach has been proposed by BACCOU ET AL. (2008).

## 5 Results

For a real-life testing of the model, a rural district of the Czech Republic has been chosen. The district has following characteristics: 102,8 thous. inhab., 1326 km<sup>2</sup>, 8 towns, largest town has 35,6 thous. inhab., 60,6% inhabitants live in settlements > 5 thous. inhab., 22,9% of inhabitants live in villages < 1000 inhabitants. There are 4 landfills receiving MSW with total capacity of 66 500 t/yr (MSW and non-toxic business waste). Two largest landfills are equipped with collection systems and co-generation units exploiting landfill gas. One landfill is equipped with collection system and bio-oxidation of landfill gas, the smallest landfill (1500 t/yr) has no treatment of landfill gas. Using information from publicly available integrated permits (IPPC), we have estimated methane emissions (collection efficiency, oxidation to CO<sub>2</sub>).

Several scenarios of advanced MSW disposal have been modelled including a new mechanical biological treatment (MBT) of MSW, production of refuse derived fuel (RDF), composting and material recovery. MBT unit is located at the largest landfill, RDF produced is transported to the largest town to be used in the centralized heating system incl. cogeneration. Material recovered at MBT is transported to the same town. Other landfills have been closed or equipped with more efficient collection systems. In parallel, Monte-Carlo modelling of output (GHGs emissions) uncertainty related to the uncertainty of input MSW composition has been carried out. Difference between MSW composition generated by rural settlements (home composting and coal/wood stoves) and apartment buildings (no home composting, central heating) has been modelled based upon housing statistics. MSW municipal statistics have been used to calculate annual generated amount of MSW per capita. Transport and collection emissions have been estimated by means of population density in settlements, road map (table of transport distances) and collection cars used (20 or 10 t capacity).

The scenarios modelled have been compared with a worst-case scenario derived from the Czech national GHGs emission inventory (MINISTRY OF THE ENVIRONMENT, 2009), which estimates that landfill gas emissions contribute by ca 2,5 mil. t/yr of CO<sub>2</sub> eq to the national GHGs emission budget. This equals approx. to 0,25 t/inhab. of CO<sub>2</sub> eq at annual MSW generation rate of 400 kg/inhab. The above estimates do not take into account oxidation of emitted methane in the upper layer of the landfill cover and/or flaring or energy use of landfill gas. In our modelled district, the worst-case CO<sub>2</sub> eq emissions per capita are 0,183 t/yr and annual average MSW production is 283 kg/inhab., which gives the worst-case emissions (0,26 t/yr CO<sub>2</sub> eq) corrected for higher MSW generation

rate close to the above national estimate. Collection and transport emissions are negligible for the worst-case scenario contributing by ca 0,5 % to the total emission budget.

For “business-as-usual“ scenario (present situation) when the estimates take into account the landfill gas treatment at the landfills the total emissions are ca 3200 t CO<sub>2</sub> eq/yr due to the collection and oxidation of landfill methane at the two largest landfills. The contribution of collection and transport is ca 3% of the total GHGs emissions. In more advanced Scenario 1, including MBT, material recovery and composting, the total GHGs emissions are 2500 t of CO<sub>2</sub> eq/yr in which the contribution of transport is ca 4-5%. Scenario 2, which takes into account production of RDF from plastics and 50% of paper present in MSW, the total GHGs emissions are about 6000 t CO<sub>2</sub> eq/yr due to the CO<sub>2</sub> emissions from the combustion of RDF. At this stage of modelling, we have not carried out any calculations of emissions avoided by a substitution of natural gas or coal by landfill gas and RDF. It is however evident that more precise emission factors and technical characteristics of the installations are needed.

In case of Scenario 2, the propagation of uncertainty related to the composition of the MSW has been modelled. MSW composition depends upon municipality character (DEN BOER ET AL., 2010), e.g. types of houses, prevailing mode of heating, average family income, lifestyle etc. It is therefore difficult to estimate a single probability distribution function related to amounts of individual MSW components. Moreover, it is possible that some types of packaging waste are substituted by others, e.g. glass containers may be substituted by plastic ones. Alternatively biodegradable textiles (cotton, wool etc.) can be substituted by synthetic ones, which mean that some inputs are not stochastically independent. Also information on landfill gas emissions are varying among published studies. Modelling, which ignores the above uncertainties in input data, may lead to biased conclusions. The Monte Carlo calculations are the only way to study propagation of the input uncertainties.

In Figure 2, the dependence of uncertainty related to the output (aggregate GHGs emissions) upon uncertainty of MSW composition is shown. Due to stochastic compensations between bio-waste production of the largest sources of MSW and the landfill and combustion (RDF) emissions, the output uncertainty (expressed as S.D.) is even lower than the input one. It means that for similar scenarios the standard deviation between 10 and 20 % rel. related to content of the major MSW components does lead to acceptable standard deviations related to the aggregated GHGs emissions (5-10% rel.). Statistical analysis of output values resulting from Monte-Carlo experiments (n=100) indicate normal distribution function.



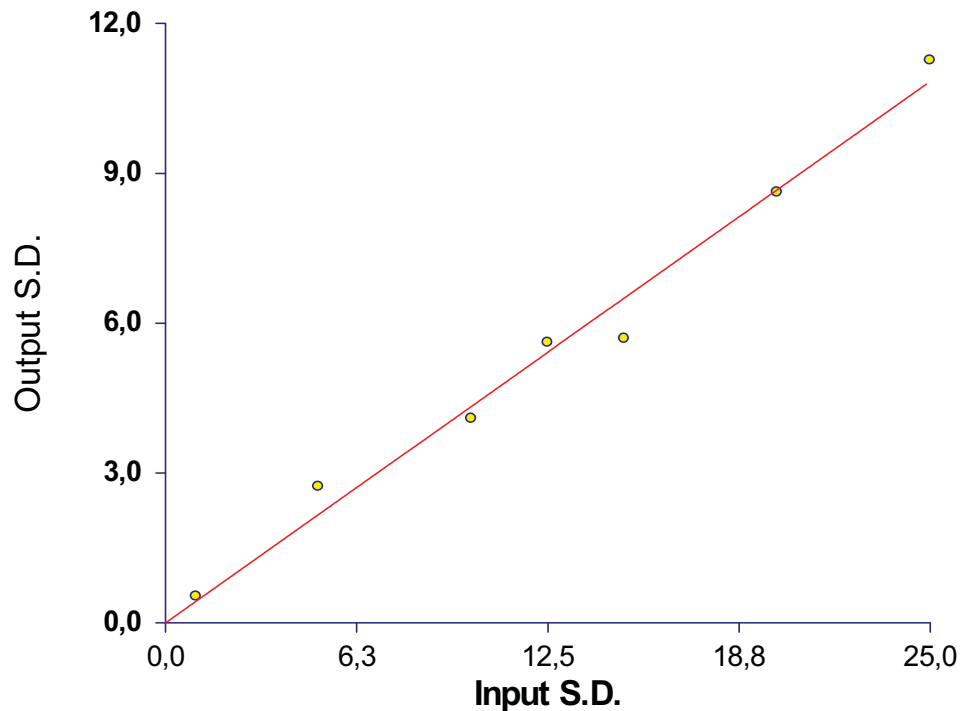

Figure 2: Linear dependence of the output standard deviation (S.D.) upon the uncertainty related to the MSW composition (slope = 0,434).

## 6 Conclusions

Algebraic modelling languages like LINGO allow easy building of integrated waste management models based upon mass or energy balance. The conceptual model described in this communication optimizes aggregated GHGs emissions resulting from MSW transport, utilization (mass or energy) and disposal. Optimal allocation of four basic components of MSW (bio-waste, recyclable materials, refuse derived fuel and inert waste) into set of installations (separators, bioreactors or composting facilities, material recovery units, energy sources fired by refuse derived fuel or methane and landfills) is modelled. Transport emissions of carbon dioxide are included.

The aggregated emissions depend upon inputs (quantity and composition of MSW) and adjustable parameters (emission factors, separation efficiencies, unit consumption of energy in installations etc.) which are known with substantial uncertainties. Due to the complexity of the model, application of Monte Carlo simulation seems to be a suitable method to estimate propagation of the uncertainties. Besides optimization of existing MSW management systems (regional or multiregional scale), optimal sitting of new installations (in combination with EIA) could be a practical application of the model.

## 7 Acknowledgment

This paper is based on a research project supported by the Ministry of the Environment of the Czech Republic (Grant VaV SP/4b1/147/08). Author thanks for helpful advices of Ludek Pur (Enviros, Czech Republic) and kind support of Lindo Systems Inc., USA.

## 8 Literature

- Baccou J., Chojnacki E., Mercat-Rommens C. and Baudrit C., 2008 Extending Monte Carlo Simulations to Represent and Propagate Uncertainties in Presence of Incomplete Knowledge: Application to the Transfer of Radionuclide in the Environment, *J. Environ. Engineering* 134 (2008) 362-368.
- McConnell S. 2005 *Code Complete: A Practical Handbook of Software Construction*, 2<sup>nd</sup> Edition, Microsoft Press, Washington
- Costi P., Minciardi R., Robba M., Rovatti M. and Sacile R., 2004 An environmental sustainable decision model for urban solid waste management, *Waste Management* 24 (2004) 277-295.
- De Boer E., Jedrczak A., Kowalski Z., Kulczycka J. and Szpadt R., 2010 A review of municipal solid waste composition and quantities in Poland, *Waste Management* 30 (2010) 369-377.
- De Feo G. and Malvano C., 2009 The use of LCA in selecting the best MSW management system, *Waste Management* 29 (2009) 1901-1915.
- Di Stefano T. and Belenky L.G., 2009 Life-Cycle Analysis of Energy and Greenhouse Gas Emissions from Anaerobic Biodegradation of Municipal Solid Waste, *J. Environ. Engineering* 135 (2009) 1097-1105.
- Ekvall T., Assefa G., Bjorklund A., Eriksson O. and Finnveden G., 2007 What life-cycle assessment does and not do in assessments of waste management, *Waste Management* 27 (2007) 989-996.
- Fiorucci P., Minciardi R., Robba M. and Sacile R., 2003 Solid waste management in urban areas development and application and application of a decision support system, *Resources, Conservation and Recycling* 37 (2003) 301-328.
- Hendrickson C.T., Lave L.B. and Matthews H.S., 2006 Environmental life cycle assessment of goods and services: An input-output approach, *Resources for the Future*, Washington.

- Manfredi S., Christensen T.H., 2009 Environmental Assessment of solid waste landfilling technologies by means of LCA-modelling, Waste Management 29 (2009) 32-43.
- Ministry of the Environment 2009 5th National Communication of Czech Republic to the Parties to UN FCCC, Prague (in Czech), [www.mzp.cz/.../cz/.../OMV-Narodni\\_sdeleni\\_CR\\_2009-20091209.pdf](http://www.mzp.cz/.../cz/.../OMV-Narodni_sdeleni_CR_2009-20091209.pdf)
- Salhofer S., Schneider F. and Obersteiner G., 2007 The ecological relevance of transport in waste disposal systems in Western Europe, Waste Management 27 (2007) S47-S54.
- Schichl H., 2003 Mathematical Modelling and Global Optimization, Habilitation Thesis, Institute for Mathematics, Vienna University.

### **Author's address**

Ing. Dipl.-Chem. Lubomir Nondek, PhD.

Integra Consulting Ltd.

Pobřežní 18/16

CZ-18600 Praha 8

Telefon + 420 728732165

E-mail: [lubomir.nondek@integranet.cz](mailto:lubomir.nondek@integranet.cz)

Website: [www.integranet.cz](http://www.integranet.cz)

# Evolution of a collection scheme in 15 years: quality and efficiency in the North Italian experience

Christian Garaffa<sup>1</sup>, Luca Mariotto<sup>2</sup>, Andrea Miorandi<sup>2</sup>, Cristian Roverato<sup>2</sup>

<sup>1</sup>Novamont Spa, Novara, Italy - <sup>2</sup>Idecom Srl, Bolzano, Italy

## Abstract

When considering organic waste collection, quality is always a critical aspect. This work summarizes the experience of the Northern Italian waste management public consortium TV3 (Treviso Tre), which has been running residential source separation schemes of organic waste since the mid 1990s. Today the mature separate collection scheme shows contamination rates of less than 2% in the collected feedstock.

The aim of the work is to show the evolution of the scheme in a timeframe of 15 years, looking at major changes and improvements that helped to achieve the present performance.

Waste characterization analyses have been an essential tool in the planning and monitoring of such schemes, and this work is based on a large data set of more than 300 analyses performed between 1998 and 2009.

Evidence is shown about how the type of collection ("fetch" schemes vs. "bring" schemes) and the choice of tools used in the household (containers and bags) is essential in determining the quality of the collected food waste.

## Keywords

Organic Waste, Food Waste, Residential Source Separation, Waste Analysis, Compostable Bags

## 1 Introduction

### 1.1 Background

At present, Italy is treating approximately 3.5 M tonnes per year of biowaste. More than one third of that is residential food waste collected separately.

According to CIC (Consorzio Italiano Compostatori), the Italian Composting Consortium, in 2008 1800 municipalities in Italy were performing residential food waste collections, serving 17.5 M people or 30 percent of the total Italian population. In 2010, the population served by residential food waste collections is estimated to be around 20 million people (CENTEMERO ET AL., 2008).

In terms of quality of the collected feedstock, in 2009 CIC performed 530 waste characterization analyses in 29 different Italian provinces. A contamination rate lower than 5%

was found in 57% of the samples; another 25% of the samples showed a contamination between 5 and 10%. The rest are above 10%.

Looking at how the food waste collection systems work in Italy, there are two predominant models: “fetch” schemes with door-to-door collection vs. “bring” schemes with large centralized containers placed on the roads (Figure 1). According to the organic waste characterization analyses of CIC, in 2009 the road container schemes showed an average contamination of 6.11%, whereas in the door-to-door schemes it was 2.52% (CENTEMERO, 2010). Although the door-to-door schemes may seem more expensive in the collection stage, recent comprehensive data demonstrate that this kind of collection is achieved without raising overall costs, keeping them at the same level or lower than the collection of bring schemes. (REGIONE LOMBARDIA, 2010; GIAVINI ET AL., 2010).



Figure 1 Road containers vs. curbside bins (food waste) and bags (residual waste)

## 1.2 The “I.S.S.O.” collection model

The door-to-door system in most cases includes curbside collection of residential food waste and will be here defined as “intensive source separation of organics” (I.S.S.O.). This method is characterized by specific features and tools that allow for high captures, low contamination rates and strong participation by citizens.

In the I.S.S.O. model, all of the waste fractions (food waste, dry recyclables and residual waste) are collected at the curbside. Unsorted waste generation is reduced because it can no longer be dropped off anonymously in centralized roadside containers.

Unlike central European systems, curbside collection of garden waste is discouraged to address waste minimization, limiting it to seasonal collection services linked to “pay as you throw” systems, and via promotion of home composting or direct delivery to recycling facilities or waste transfer stations (FAVOINO ET AL., 2006). Recent research from the UK confirms that schemes with combined food and garden waste collection achieve a much lower yield per household, compared to weekly food waste only collections,

and hence a lower level of diversion of food waste from the residual waste (WRAP, 2010). In the I.S.S.O. model, all of the collections are intimately connected, focusing on the management of food waste. The system calls for high frequency collections of food waste in order to keep the organic fraction low in the residual waste stream (less than 10%). Food waste collection typically ranges from one to three times a week, depending on season and local climate conditions (mediterranean/continental). Because of the reduced content of putrescible materials, residual waste can therefore be collected on a weekly or biweekly (fortnightly) basis.



*Figure 2 Mechanical and manual tipping of food waste in compostable bags*

The food waste is collected in smaller (3- to 5-m<sup>3</sup> capacity), quicker, cheaper and more environmentally friendly (e.g. methane powered) collection vehicles, without compaction (Figure 2). There is also manual tipping of 35-liter bins for single houses, which allows for reduced pick-up time compared to mechanical tipping of larger bins (condominiums are still provided with 120- to 240-liter bins, serving 10 to 20 households each). A final feature of the system is the use of indoor household tools for maximizing ease of use and increasing participation. Vented kitchen bins (8-liter) and yearly supplies of compostable bags are given to each household (Figure 3). Bags are certified according to European compostability standard EN 13432.



*Figure 3 Vented kitchen bins and compostable bags*



## 2 The experience of the waste consortium TV3

In the present study the results of a series of waste characterization analyses are shown and discussed. The analyses refer to the residential food waste fraction collected in the area managed by the waste management public consortium Treviso 3 (TV3).

The territory of TV3 has a population of approximately 220.000 inhabitants and lies on the western part of the Province of Treviso within the Veneto Region, in the north-eastern part of Italy (about 30 Km from Venice). It includes 25 Municipalities scattered on an area of approximately 620 Km<sup>2</sup>. The two main Municipalities are Castelfranco Veneto (33.591 inhabitants in 2008) and Montebelluna (30.887 inhabitants in 2008). In the residential areas detached or semi-detached housing is predominant together with low-rise buildings.

Table 1 Waste data of the TV3 Municipalities in the period 2004-2008

Municipality	Population	Waste per capita (kg/inh*y)	Total waste (Tons)	Separate collection (Tons)	S.c. % 2004	S.c. % 2005	S.c. % 2006	S.c. % 2007	S.c. % 2008
Altivole	6.679	346	2.310	1.571	63,75	63,97	64,34	64,12	68,02
Asolo	9.222	330	3.048	2.083	64,28	62,96	68,89	64,17	68,35
Borso del Grappa	5.756	367	2.112	1.266	60,5	60,85	60,51	62,02	59,95
Caerano di San Marco	7.941	386	3.069	2.076	67,56	67,92	67,13	67,53	67,63
Castelcucco	2.173	376	816	571	68,47	66,94	66,6	68,48	70,00
Castelfranco Veneto	33.591	498	16.725	10.811	64,57	64,26	64,52	61,71	64,64
Castello di Godego	7.018	334	2.346	1.611	63,61	64,83	64,95	65,45	68,68
Cavaso del Tomba	2.965	381	1.130	715	61,02	59,74	60,58	60,41	63,28
Cornuda	6.183	394	2.436	1.639	66,81	65,34	66,42	64,97	67,28
Crespano del Grappa	4.767	400	1.908	1.204	61,13	59,91	61,05	61,83	63,11
Crocetta del Montello	5.989	384	2.301	1.457	61,14	62,57	63,69	60,99	63,32
Fonte	6.119	350	2.143	1.423	67,32	64,57	66,45	65,5	66,41
Istrana	9.055	360	3.260	2.046	57,01	58,99	60,73	63,86	62,77
Loria	8.913	289	2.579	1.623	57,94	57,97	58	59,48	62,91
Maser	4.913	371	1.824	1.285	67,74	67,78	71,08	69,67	70,43
Monfumo	1.463	284	416	287	68,59	65,12	66,36	68,19	69,12
Montebelluna	30.887	465	14.354	10.461	73,81	72,88	73,69	71,47	72,88
Paderno del Grappa	2.161	391	844	549	62,2	59,95	62,97	62,65	65,00
Pederobba	7.466	413	3.084	2.106	66,17	64,98	65,52	64,83	68,31
Possagno	2.260	421	952	642	65,46	61,16	65,18	67,48	67,41
Resana	9.125	352	3.210	2.040	62,4	64,47	64,72	64,68	63,54
Riese Pio X	10.821	344	3.718	2.359	65,34	63,77	63,59	63,63	63,46
San Zenone degli Ezzelini	7.383	306	2.258	1.513	68,59	67,83	66,86	66,64	67,03
Trevignano	10.424	314	3.275	2.226	69,61	68,04	68,04	68,48	67,97
Vedelago	16.455	325	5.352	3.325	55,54	56,75	60,17	62,04	62,13
<b>Total / Average</b>	<b>219.729</b>	<b>367</b>	<b>85.467</b>	<b>56.890</b>	<b>64,42</b>	<b>63,74</b>	<b>64,88</b>	<b>64,81</b>	<b>66,15</b>

The TV3 collects organic waste, dry recyclables and residual waste separately. It has now reached an overall diversion rate of almost 70% (Table 1). The organic fraction has been collected since 1994. In a timeframe of fifteen years, the scheme has gone through three very distinct stages.

1. Until July 2000 the organic waste collection was based on a “bring” scheme, with large centralized containers placed on the roads serving all the households of one or more streets.
2. After July 2000 the system moved to a “fetch” scheme with curbside collection (door-to-door). In this second phase, the households were using non-compostable plastic bags to collect the food waste. Bags were opened and plastic contamination was screened out at the composting facility.
3. Finally, in June 2008 after the introduction of mandatory use of certified compostable bags for food waste collection, according to the national environmental law D.Lgs.152/2006, the consortium started distributing to the households yearly supplies of certified compostable bags. The considerable improvement in the quality of the collected material led to the optimization of the pretreatment process at the composting facility by removing the front-end debagging and screening stages.

## 2.1 Waste characterization analyses

During the evolution of the system, waste characterization analyses have been the primary tool for understanding the weak points and the margins for improvement. In the first years the analyses were performed by the consortium TV3 itself; between 1998 and 2003, the regional agency of the environment of Veneto (ARPAV) conducted the analyses in order to develop a standard methodology which can be found in the annex B of the “regional technical directive on composting” approved by the regional bill DGRV 766/2000 (Giunta Regionale Veneto, 2000) and confirmed by the DGRV 568/05 (Giunta Regionale Veneto, 2005). The analyses after 2003 were performed by the waste consulting company Idecom Srl, according to the above mentioned methodology.

## 2.2 Quality classes

In 1998, the Authority of the Regione Veneto finished a framework agreement with the composting facilities based on its territory (Giunta Regionale Veneto, 1998). This agreement was confirmed by the bill DGRV 568/05 (Giunta Regionale Veneto, 2005) and sets criteria for the acceptance of the collected feedstocks. It defines three quality classes depending on the contamination rate as shown in Table 2.

Table 2 Quality classes of the collected organic waste according to DGRV 568/05

	Class A	Class B	Class C
% in weight of non compostables	$X < 2,5$	$2,5 < X < 5$	$X > 5$

## 2.3 Evolution of the collection system

### 2.3.1 Phase 1: “bring” scheme with large centralized containers on the roads

From 1994 to July 2000 the separate collection was based on a “bring” scheme with large centralized containers placed on the roads, each serving the households of one or more streets. Besides dry recyclables and residual waste, organics were also collected this way. A waste characterization campaign performed between July and October 1998 in 20 municipalities of the consortium showed an average contamination rate of the collected organic fraction of 12,7% (LAZZARI, 1998).

### 2.3.2 Phase 2: “fetch” scheme with curbside collection in polyethylene bags

Given the overall high contamination and the low yields, in July 2000 the consortium switched to a “fetch” scheme with curbside collection of all the waste fractions (food waste, paper and cardboard, glass and cans, plastics, residual waste). For collecting the food waste, detached and semi-detached houses were supplied with 25-liter bins and transparent polyethylene bags. Multifamily buildings with more than 5 households were provided with 120- or 240-liter wheeled bins. Collection frequency was two times a week.

After more than one year from start up, between November 2001 and January 2002 the first waste characterization campaign was made to assess the performance of the Phase 2 collection system. The main result was a 75% reduction of the contamination, but the polyethylene bags alone were accounting for 1,5% of contamination causing also a drag effect towards additional contamination (BENAZZATO, S. ET AL., 2002). To this respect, an assessment by the Environmental Protection Agency of the Veneto Region (ARPAV) on Municipalities of the Region had already shown that collecting food waste in compostable bags would allow for total contamination rates lower than 1% (BOZZO, G.P. ET AL., 2001). Between 2003 and 2005, yearly characterizations were made (except for 2004) on all the 25 municipalities of the consortium. The average results are shown in Table 3.

Table 3 Average contamination of the collected food waste in TV3

Year	2003	2005	2006	2007
% in weight	4,49%	6,03%	3,56%	4,63%

### 2.3.3 Phase 3: “fetch” scheme with curbside collection in compostable bags

In order to reach the highest purity of the collected material, in 2008 the TV3 decided to distribute to each household a yearly supply of compostable bags and a vented bin to be stored in the kitchen. The choice of distributing directly these tools to the citizens had 3 goals:

1. Avoid the risk of the householders not using compostable bags;
2. Limit the contamination of plastics in the food waste;
3. Perform education activities during the delivery of the tool kits.

The waste characterization analyses performed in 2008 (after the delivery of the compostable bags) and in 2009 showed a significant increase in the quality of the collected feedstock. Almost all municipalities were falling under quality class A. Table 4 summarizes the average contamination rates of the 25 municipalities during the two different phases before (2003-2007) and after (2008-2009) the introduction of the compostable bags. The different colours refer to the different quality classes of the collected material according to DGRV 568/05 (Table 2).

Table 4 Contamination rates of the food waste collected in TV3 from 2003 to 2009

Municipality	Year					
	2003	2005	2006	2007	2008	2009
ALTIVOLE	4,56%	5,60%	3,38%	4,93%	1,70%	1,42%
ASOLO	4,57%	6,41%	4,25%	3,95%	3,96%	1,43%
BORSO DEL GRAPPA	3,15%	4,42%	2,26%	4,46%	1,79%	1,83%
CAERANO SAN MARCO	3,88%	6,67%	3,36%	4,84%	1,56%	1,34%
CASTELCUCCO	4,45%	6,16%	3,60%	3,51%	1,33%	1,21%
CASTELFRANCO VENETO	6,67%	6,59%	6,80%	8,14%	0,86%	2,57%
CASTELLO DI GODEGO	3,66%	6,42%	4,37%	2,73%	1,75%	2,29%
CAVASO DEL TOMBA	4,34%	3,62%	4,44%	3,70%	2,07%	0,88%
CORNUDA	3,35%	6,84%	4,00%	4,29%	1,54%	1,34%
CRESPANO DEL GRAPPA	3,83%	6,68%	2,72%	3,96%	3,37%	1,58%
CROCETTA DEL MONTELLO	4,24%	5,56%	2,07%	3,49%	1,04%	1,88%
FONTE	4,71%	5,64%	3,95%	3,74%	2,99%	1,83%
ISTRANA	3,22%	5,72%	4,02%	3,36%	2,31%	1,12%
LORIA	5,70%	5,77%	2,43%	4,61%	2,15%	4,48%
MASER	3,18%	5,59%	2,21%	4,47%	1,34%	0,70%
MONFUMO	4,73%	6,17%	3,43%	4,39%	1,62%	1,28%
MONTEBELLUNA	9,33%	7,00%	6,68%	6,89%	2,51%	1,07%
PADERNO DEL GRAPPA	4,69%	7,73%	2,33%	4,23%	3,87%	2,95%
PEDEROBBA	4,95%	6,28%	2,23%	4,19%	1,54%	1,28%
POSSAGNO	4,63%	5,76%	3,35%	3,04%	3,30%	1,30%

RESANA	4,44%	5,75%	3,32%	12,79%	2,67%	1,50%
RIESE PIO X	3,87%	7,43%	4,31%	2,98%	1,69%	1,74%
SAN ZENONE DEGLI EZZELINI	4,49%	6,22%	2,28%	4,98%	3,28%	1,37%
TREVIGNANO	3,15%	4,76%	3,01%	3,39%	1,25%	0,63%
VEDELAGO	4,37%	5,84%	4,31%	4,65%	1,63%	1,33%
<b>AVERAGE</b>	<b>4,49%</b>	<b>6,03%</b>	<b>3,56%</b>	<b>4,63%</b>	<b>2,12%</b>	<b>1,61%</b>

Class A <2,5%
Class B 2,5% < X < 5%
Class C > 5%

## 2.4 The composting facility

### 2.4.1 General features

The TV3 waste management public consortium owns an in-vessel composting facility of 35.000 tonnes per year capacity based in Trevignano. The facility is certified ISO14000 and produces quality compost in accordance with the regional bill DGRV 568/05 (Giunta Regionale Veneto, 2005). There is an enclosed area of 7.200 m<sup>2</sup> under negative pressure which includes the waste delivery and storage zone, the pretreatment and the active composting areas. The facility is treating all the biowaste collected by TV3 (food waste and garden waste). The technology uses automated windrow turning equipment, air insufflation, moisture control and leachate recirculation. Maturation occurs outdoors where the compost piles are turned repeatedly with a wheel loader. Final product refining is performed with a 40-mm sieve.

### 2.4.2 Impact of polyethylene contamination

Until 2008 (before the introduction of compostable bags), a bag opener and a 100-mm drum screen were used in the pre-processing stage. After screening of the input material, the overs were sent to disposal and the fines were mixed with green waste and composted. Since 2002, approximately every 3 months characterization analyses were made on the overs and fines in order to monitor the screening efficiency and the drag effect of the screened bags that were pulling with them significant portions of organic material. Table 5 shows the percentage of overs generated during the pretreatment. Because of the high amount of material excluded by the primary screening process (average 42,22%), during 2003 it was decided to put the overs through a second screening step in order to maximise the inputs. This secondary screening step allowed a reduction

to 20,44% in average of the residues generated, but was more time and energy consuming as it required a second transit through the drum screen.

Table 5 Efficiency of the primary and secondary screening at the composting facility

Date	% of overs (weight)	Screening step
12-dec-02	37,96%	Primary
16-dec-02	40,76%	Primary
19-dec-02	42,29%	Primary
21-may-03	26,58%	Secondary
18-jul-03	47,89%	Primary
18-jul-03	27,98%	Secondary
17-oct-03	19,12%	Secondary
30-apr-04	20,05%	Secondary
29-mar-05	19,12%	Secondary
8-jul-05	25,65%	Secondary
7-ott-05	26,92%	Secondary
22-dec-05	19,09%	Secondary
17-mar-06	18,39%	Secondary
14-jun-06	17,00%	Secondary
4-jul-06	21,75%	Secondary
30-aug-06	18,31%	Secondary
24-nov-06	15,25%	Secondary
20-mar-07	16,23%	Secondary
29-jun-07	15,77%	Secondary
8-jul-07	25,65%	Secondary
7-oct-07	18,37%	Secondary
13-dec-07	18,76%	Secondary
25-jun-08	18,37%	Secondary
<b>AVERAGE</b>	<b>42,22%</b>	<b>PRIMARY</b>
<b>AVERAGE</b>	<b>20,44%</b>	<b>SECONDARY</b>

### 2.4.3 Removal of the pre-treatment step

After the introduction of the compostable bags and the significant reduction of contamination, in July 2008 the bag opening and screening steps at the front end of the process were removed. Besides the savings of time and energy consumption, the most significant impact of this change was the avoided overs sent to disposal. Considering that the total volume of food waste per year treated by the facility has not changed significantly, a comparison between the total quantities of residues generated by the screening proc-



esses in the years 2007 (still with high plastic contamination) and 2009 (only compostable bags) shows a net balance of 2.000 tonnes of avoided disposal (Table 6).

Table 6 Total residues generated by the screening processes (tonnes)

	Year 2007	Year 2009
Overs from the front end pre-treatment	2.500	-
Overs from the final refining screening	1.100	1.600
Total residues generated	3.600	1.600

### 3 Conclusion

In terms of quality of the separately collected organic waste, a first threshold of acceptability can be identified when a purity of about 90-93% is reached. This level makes it possible to recover the organic waste for quality compost production, however relatively complex screening and refining systems at the composting facility are needed. A threshold of excellence could be defined with a purity of 96-97%. This limit meets the needs of very simple and less expensive ways of refining and separating the non-compostable contaminants. In other words, by keeping contamination rates lower than 3-4%, it is possible to simplify the pre-treatment systems and keep a simple sieving step at the end of the process for refining the final product, with significant savings on capital investments and operational costs of additional machines.

The experience of the waste management consortium TV3 shows that the collection phase has an important impact on the subsequent treatment phase:

- Fetch schemes at the curbside are much more efficient compared to bring schemes in centralized containers in terms of quality and yields of the collection;
- Mechanical screening processes do not guarantee the most efficient levels of recovery. The best way to achieve this is by ensuring a good quality of the source separated material;
- The direct distribution of compostable bags in combination with collection tools like vented kitchen bins has ensured the highest purity levels of the collected food waste;
- The use of compostable bags has allowed for significant savings at the composting facility, such as:
  - a. Removal of the front end screening system;
  - b. Significant reduction of the residues and related transport and disposal costs.

## 4 Literature

- Benazzato, S., Lazzari, L., Mariotto, L. 2002 *Validazione dei sistemi di gestione di raccolta differenziata del rifiuto organico attraverso lo strumento dell'analisi merceologica. L'esperienza nel Bacino Treviso Tre..* Proceedings of "Ricicla 2002
- Bozzo, G.P., Franz, L., Germani, F., Giandon, P., Roverato, C. 2001 *Composition of Municipal Waste (MW) in Veneto Region".* Proceedings Sardinia 2001, Eighth International Waste Management and Landfill Symposium, pp.3-12.
- Centemero, M., Zanardi. W. 2008 *Il trattamento biologico dei rifiuti urbani in Italia: compostaggio, trattamento meccanico-biologico, digestione anaerobica.* From "Biogas da rifiuti solidi urbani". Ed Flaccovio, 2008. pp. 1-16.
- Centemero, M. 2010 *La frazione organica dei rifiuti e la digestione anaerobica.* Proceedings of the conference "La digestione anaerobica della frazione organica dei rifiuti urbani" 23 marzo 2010, Facoltà di Agraria - Università degli Studi di Milano
- D.Lgs. 152/06 2006 *Decreto Legislativo 3 aprile 2006, n. 152 - Norme in materia ambientale*
- D. Lgs. 4/08 *Ulteriori disposizioni correttive ed integrative del D. Lgs 3 aprile 2006.*
- Favoino, E., Ricci, M., 2006 *The Economics of Different Separate Collection Schemes for Biowaste.* Proceedings of the ECN/ORBIT e.V. - First Baltic Biowaste Conference 2006
- Giavini, M., Garaffa, C., Ribaudo, A., Ghiringhelli, G. 2010 *Innovative evaluation of economic data on source separation schemes in Lombardy, Italy.* Proceedings of the ORBIT2010 conference – June 29 – July 3, 2010, Heraklion, Greece.
- Giunta Regionale Veneto 1998 *Deliberazione n. 2.297 del 22 giugno 1998 (Accordo di programma tra la Regione Veneto e gli impianti di compostaggio del Veneto).*
- Giunta Regionale Veneto 2000 *DGRV (Delibera della Giunta Regionale Veneto) 766/2000. BURV n. 38 del 25/04/2000*

Giunta Regionale Veneto	2005	<i>DGRV (Delibera della Giunta Regionale Veneto) 568/05.</i>
Lazzari, L.	1998	<i>Indagine sulla qualità della frazione organica proveniente dalla raccolta differenziata all'interno del bacino TV3.</i>
Puig, I. et Al.	2008	<i>Municipal handbook on door to door separate waste collection in Catalonia (Spain).</i> Proceedings of the ORBIT2008 conference – 13-15th of Oct. 2008, Wageningen, The Netherlands.
Regione Lombardia, Direzione Generale Reti, Servizi di Pubblica Utilità e Sviluppo Sostenibile	2010	<i>Valutazione statistico-economica dei modelli di gestione dei rifiuti urbani in Lombardia.</i>
WRAP, Waste and Resources Action Programme	2010	<i>Performance analysis of mixed food and garden waste collection schemes – Final report</i>

### **Authors' addresses**

Christian Garaffa  
 Novamont Spa  
 Via Fauser, 8  
 I-28100 Novara  
 Phone +39 0321 699 693  
 Email: christian.garaffa@novamont.com  
 Website: www.novamont.com

Cristian Roverato  
 Idecom Srl - GmbH  
 Via Innsbruck, 33  
 I-39100 Bolzano  
 Phone +39 0471 949 802  
 Email: cristian@idecom.it  
 Website: www.idecom.it

# Zagreb Municipal Waste Management – Vienna or Naples Model?

Vladimir Potočnik, M.Sc.M.E

Croatian Center Knowledge for Environment, Zagreb, Croatia

## Abstract

Croatian capital Zagreb for the third time is attempting to build Waste-To-Energy (WTE) plant. Zagreb WTE plant is planned to treat thermally residual municipal solid waste (MSW) and sludge from the existing Zagreb waste water treatment plant, and to produce energy from waste. The project has been postponed mainly due to opposition of some environmental organizations.

Experiences of developed countries demonstrate that WTE plants as a rule are integral unavoidable parts of successful municipal waste management systems in the middle and large cities. The main reasons for this are:

- high recycling quotas,
- hygienic aspects,
- mitigation of climate change,
- substitution of imported energy,
- reduction of import dependency and foreign trade deficit,
- organic part of MSW is renewable energy.

Comparison of two completely different models for solution of the MSW problem - cities of Vienna and Naples – clearly indicates which model is more acceptable for the city of Zagreb, as well as for other similar cities.

## 1 Introduction

With the opening in 1965 of the landfill Jakusevec in the capital of Republic Croatia Zagreb, planning of the Waste-To-Energy (WTE) plant Zagreb started. According to this plan Zagreb WTE plant had to be located close to the existing CHP Zagreb-East through which energy from waste should be delivered to the City's heating and electrical networks. Political disturbances in Croatia at the beginning of 1970's postponed the project. The project was restarted in 1980's on the same site in cooperation with CHP's operator Croatian Power utility, but again it was stopped in 1990's due to the system transition process and war in Croatia. In a meantime the landfill Jakusevec considerably grew, and it became dangerous threat to underground water, air and population, so that its remediation had to be undertaken. At the same time the WTE project was initiated in the year 2000 for the third time, now sited in Ivanja Reka, close to the recently built municipal Waste Water Treatment Plant Zagreb. Zagreb WTE plant should thermally treat

municipal solid waste (MSW) together with sludge from the Waste Water Treatment Plant. WTE construction preparatory activities have been mostly performed, but the project began again to be delayed by actions of some environmental groups, claiming that this project is not necessary because the problem of MSW could be solved only by waste reduction and recycling.

Closing of the landfill Jakusevec is planned after 2010, and the Waste Water Treatment Plant has limited space for temporary disposal of the generated sludge.

Is it possible that city of Zagreb solves its waste problems only by waste reduction and recycling? The answer to this question should be found in the relevant world experiences.

## 2 World Experiences

The waste problem is highly ranked environmental problem. In the Croatian Environmental protection strategy (1) the waste problem has the highest rank. Although the MSW makes smaller part of a total waste quantity (Figure 1), its role is considerably bigger due to its composition diversity, and because it is related to all citizens.

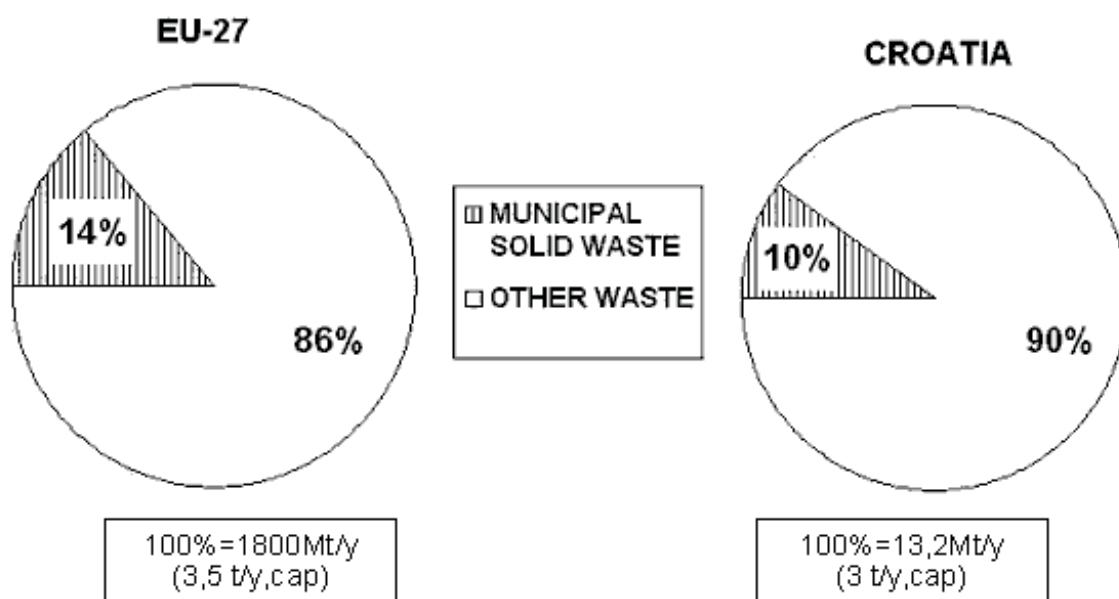

Figure 1 Waste generation 2004 in EU-27 and Croatia

Waste problem is solved by means of modern waste management systems, based on the sustainable waste management concept RUD (Reduction – Utilization – Disposal), which includes number of adequate measures and technologies, from waste generation prevention, over recycling to final disposal.

The objective of such systems is to reduce as much as possible harmful waste impacts on the environment, climate and health together with simultaneous utilization of valuable material and energy properties of the waste.

## 2.1 Concept RUD

The sustainable waste management concept RUD has been adopted in the city of Zagreb in 1991, and in the Croatia through Waste management strategy 2005 (2). Basic elements of the concept RUD are based on positive world experiences (Figure 2).

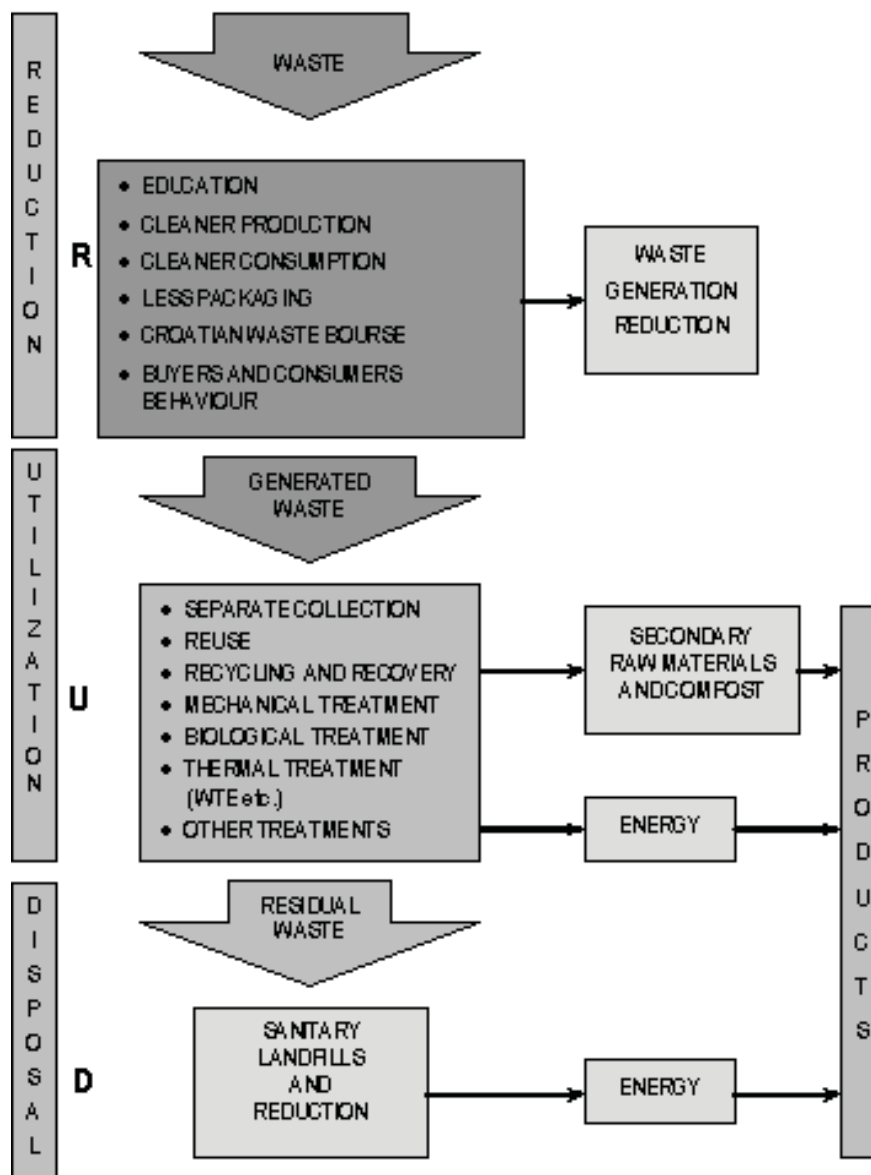

Figure 2 Sustainable waste management concept RUD

The concept RUD is composed of the three hierarchically arranged phases:



- **Waste Reduction R** with objective to reduce waste quantity and harmful properties of the waste as much as possible, so that minimal waste quantity enters the waste management system.
- **Waste Utilization U** with objective to utilize material and energy properties of the waste for generation of the secondary raw materials and energy. This phase begins with waste components separate collection, and includes recycling, composting and waste treatments.
- **Waste Disposal D** on the sanitary landfills (new or remediated existing) has the lowest rank in the waste hierarchy.

Zero waste concept (3) is based on environmentally positive but utopian idea, that waste problem could be solved exclusively by the waste reduction, recycling and composting, without waste thermal treatment and landfills. It is tried to prove general feasibility of this idea in Croatia by means of rare examples of achieved high recycling quotas in the world. Real performances in Croatia and in the world are very distant from this idea, and they have no chance for realization due to economic and social reasons.

## 2.2 Municipal solid waste (MSW) management

Continuous urban population and living standard increase result in continual growth of the generated MSW in spite of waste generation reduction measures (Figure 3).

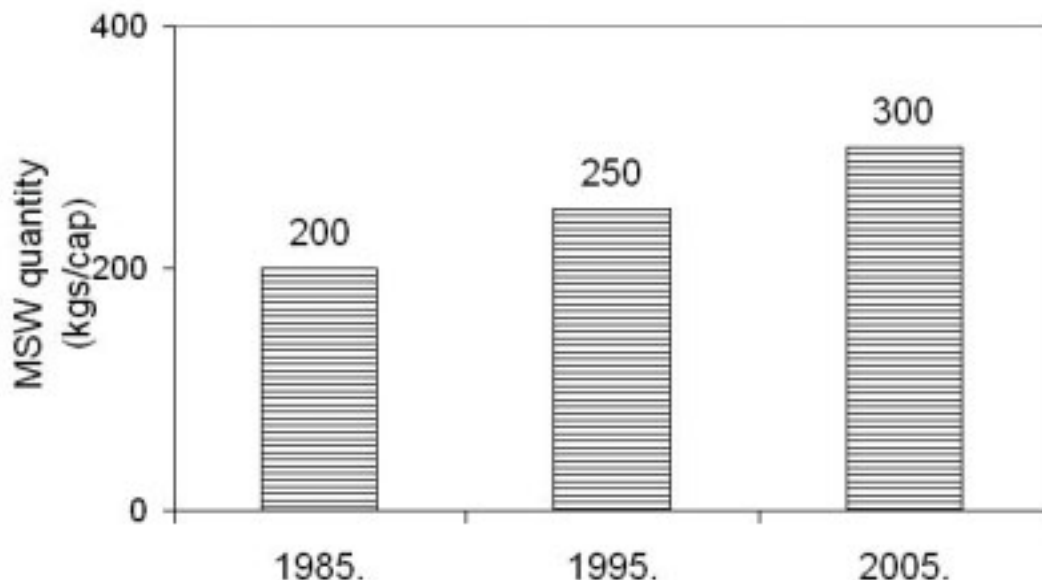

Figure 3 Specific MSW quantity in the world 1985 to 2005

Large differences of MSW generated in various parts of the world are present (Figure 4).

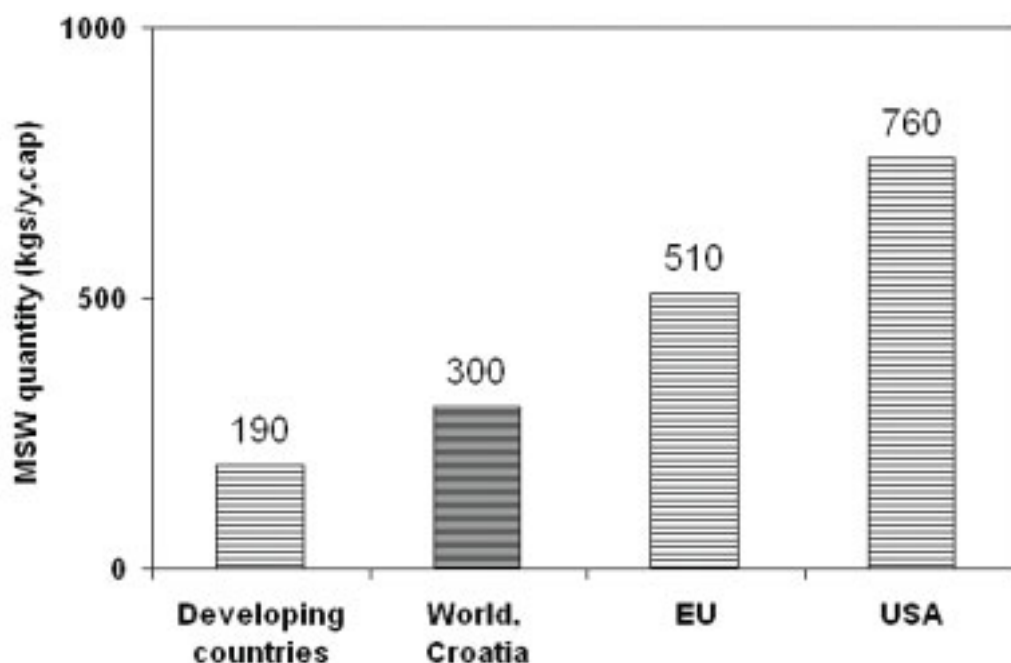

Figure 4 Specific MSW quantity 2005 (EEA, EPA)

Specific MSW quantity per capita in the USA is four times higher than in the developing countries, and about 2.5 times higher than world average. MSW management structures in the EU, USA and Croatia are presented in Figure 5.

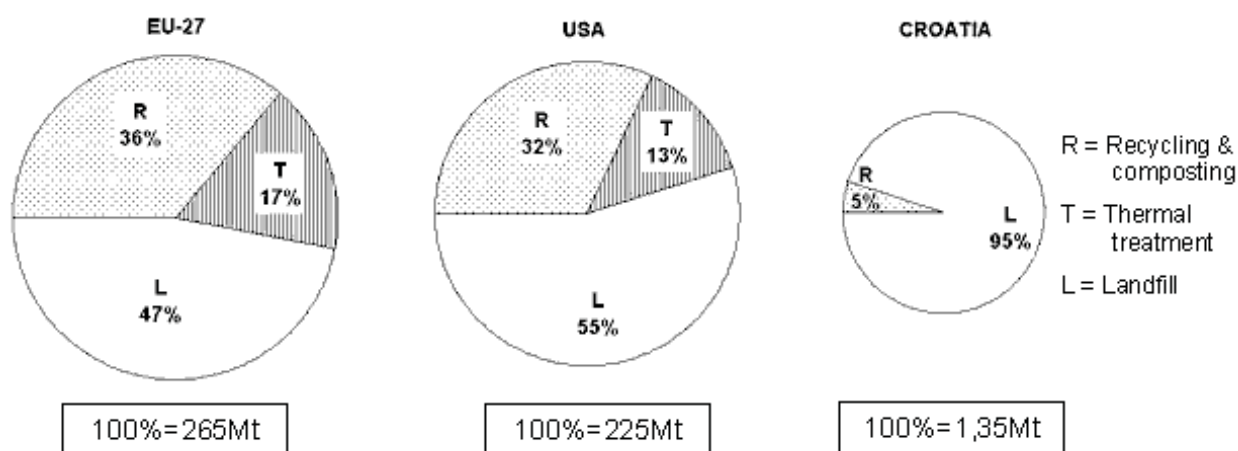

Figure 5 MSW management structure 2005

In spite of great efforts to increase waste recycling and treatment in the most developed parts of the world, approximately one half of the MSW still ends on the landfills. There are great differences in the MSW management structure between various EU countries (Figure 6).

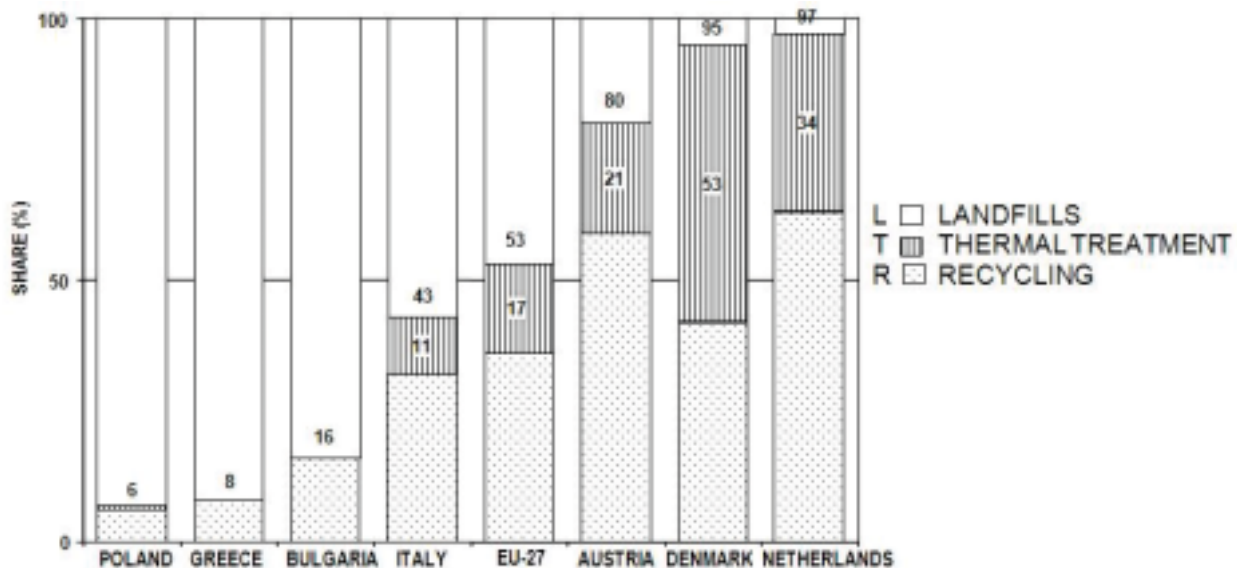

Figure 6 MSW management structure 2005 in EU-27 (4)

The highest share of the MSW was landfill in Poland (94%) and Greece (92%), and the lowest share in Denmark (5%) and Netherlands (3%), due to large differences of the relevant recycling quotas (including composting) and participation of the waste thermal treatment. Recycling quotas have been:

- 5% to 8% in Poland and Greece
- 42% to 63% in Denmark and Netherlands.

The share of the MSW thermal treatment (WTE) was between 0% in Greece and Bulgaria, and 34% in Netherlands or 53% in Denmark.

Figure 6 also illustrates the fact that high recycling quotas are registered in countries with high shares of the thermal treatment. It means that MSW thermal treatment does not block waste recycling, but contrary to that, it acts stimulating to the recycling. Similar results are registered in the USA, where towns and states with high shares of the MSW thermal treatment simultaneously have large recycling quotas as well.

Recycling potential is frequently overestimated, supposing theoretical potential, which is impossible to realize due to sociological (cooperation of the population), technical (complexity and waste components quality), and economic (saleability of secondary raw materials and costs) limitations.

## 2.3 MSW thermal treatment

MSW thermal treatment is available in different forms:

- WTE cogeneration plants produce energy from waste (EfW)

- Co-combustion of refuse derived waste (RDF) with fossil fuels in the industrial plants (cementworks, ironworks, etc.) and thermal power plants
- Landfill gas cogeneration plants
- Waste incineration plants are combusting MSW without energy recovery, applicable only for hazardous waste

WTE cogeneration plant functions similar to district or industrial cogeneration plant, combusting MSW instead of fossil fuels. First MSW incineration plants have been constructed more than 130 years ago in the United Kingdom (Nottingham 1874). Since then MSW thermal treatment technology has been continuously developed and improved. Today, there are about 1000 WTE plants in the world, with more than 400 in Europe.

- MSW WTE plants are important element of the modern waste management systems due to the following reasons:
- WTE plant has high MSW recycling quota of approximately 70%, transforming waste to energy, respectively 95% when combustion residuals (slag, iron) are utilized.
- MSW thermal treatment is the most hygienic waste disposal technology because it destroys all pathogen elements (bacteria, viruses).
- Generation of energy from waste is increasingly interesting due to high growth and instability of the fossil fuels prices, and due to the mitigation of climate change (organic part of MSW is renewable energy).
- MSW thermal treatment considerably reduces landfills surfaces.
- Energy from waste reduces energy imports and related foreign trade deficit.

### **3 Story of waste from two towns**

MSW problems are more complex in larger towns, and for their solution increasingly complex waste management systems are required.

Two completely different models for the MSW problem solution represent the towns:

- Vienna (Austria) as a successful model, and
- Naples as an unsuccessful model.

### 3.1 Vienna MSW

Austrian capital Vienna with population of about 1,6 millions has an integrated MSW management system, whose structure is presented in the Figure 7.

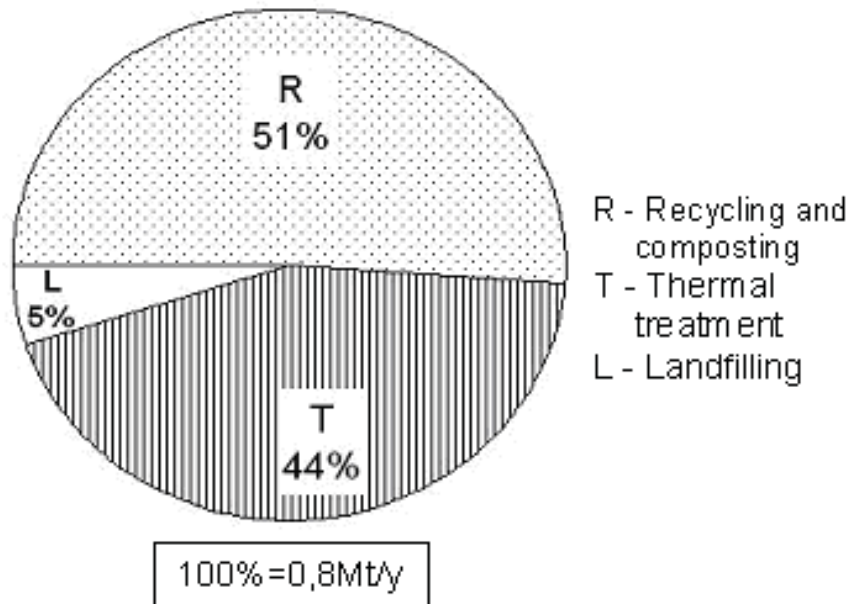

Figure 7 Vienna MSW management structure (6)

Thanks to high share of the MSW thermal treatment, recycling and composting only about 5% of untreated MSW is disposed off on the landfill Rautenweg, whose closure is planned after the year 2020.

Integrated MSW system includes four WTE plants (Table 1) and ABA Rinter AG waste management center for about 450000 tons yearly, with different MSW plants.

Table 1 Vienna WTE plants (6)

WTE plant	OPERATION START	CAPACITY(t/y)		
		MSW	Sludge	Hazardous waste
Flötzersteig	1963	200 000	-	-
Spittelau	1971	260 000	-	-
Simmeringer Haide	1980	100 000	200 000	100 000
Pfaffenau	2008	250 000	-	-
<b>TOTAL</b>	-	<b>810 000</b>	<b>200 000</b>	<b>100 000</b>

All WTE plants are in the scope of District heating Vienna (Fernwärme Wien) producing about 22% of heating energy from 60% of Vienna's MSW.

The fire in 1987 damaged significant part of the WTE Spittelau, located close to the Vienna center. After this accident the plant was restored according to the project of the well-known architect Hundertwasser, becoming one of the Vienna symbols (Figure 8).



*Figure 8 WTE plant Spittelau Vienna*

All emissions of the WTE plants in Vienna are controlled and kept well below permitted limits.

Vienna waste management system represents good model for many towns all around the world, thanks to its positive environmental, climate, economic and sociological results.

### **3.2 Naples MSW (7)**

Waste crisis in the city of Naples (population about one million), one of the Italian tourist pearls, is lasting more than 10 years. The crisis culminated in the season 2007/8, when the police and army had to intervene and the new Italian government of Mr. S. Berlusconi had the first session just in Naples.

Naples landfills were closed due to the overfilling, and the attempts to reopen them were blocked by the nearby population. For some time the MSW has been transported to the neighboring Italian regions, but soon it was banned. The MSW was then exported to some European towns (Hamburg, etc.) with rather high costs. All this was insufficient,



so that at the beginning of the year 2008 MSW started to accumulate on the Naples streets, and the embittered citizens put the fires, conflicting with the police (Figure 9).



*Figure 9 Waste crisis in Naples*

The main reasons of the “waste Crisis” in Naples are the following:

- Unrealized waste management plans with several WTE plants and landfills, mainly due to resistance of environmental organizations and local population.
- Low waste recycling quotas, less than 10% (the lowest in Italy).
- Considerable influence of the criminal organization Camorra, which many years realized large profits (more than one billion € yearly) by illegal landfilling of hazardous wastes from other Italian regions.

Among other negative effects due to the waste crisis, Naples with surrounding was proclaimed in medical circles as “death triangle” because of increased mortality from cancers and genetic deformation of the nervous and urinary systems.

New Italian government undertook urgent measures to mitigate “waste crisis” in Naples and the region Campania:

- Ex-police chief was nominated as commissioner for the Naples waste.

- Construction of three WTE plants in Naples and Campania was mandated in the next three years.
- Increase of waste separate collection and recycling.
- Preparation of the waste management strategy in accordance with EU regulation.

## 4 Conclusion

During last forty odd years the capital of Croatia Zagreb is trying to build Waste-To-Energy (WTE) plant. Two attempts in the 1970's and 1990's failed mainly due to political reasons. The landfill Jakusevec close to the river Sava grew considerably, endangering ground waters, environment and surrounding population, so that it had to be costly remediated. Third attempt to build WTE plant Zagreb is under way, this time with objective to treat thermally the MSW and the sludge from the existing Waste water treatment plant Zagreb. This attempt is exposed to strong opposition of some environmental groups, which intend to impose unrealistic "zero waste" concept, namely that waste problem in Zagreb should be solved exclusively by waste reduction and recycling without "dangerous" WTE plant.

However world experiences demonstrate that waste problem in more developed parts of the world is solved as a rule by means of the modern waste management concept RUD (Reduction – Utilization – Disposal) with many elements, including recycling, composting and WTE plants,

Comparing two extremely different waste management models – Vienna model with all elements of the modern waste management system, including four WTE plants, and Naples model without these elements, which entered serious "waste crisis" – it is not difficult to conclude which model would be more appropriate to the city of Zagreb.

This is no doubt Vienna model, adjusted to local conditions and possibilities.

## 5 Literature

- |              |      |   |
|--------------|------|---|
| NN           | 2002 | National environmental protection strategy, 46/2002                       |
| NN           | 2005 | Croatian waste management strategy, 130/2005                              |
| NN           | 2007 | Zero Waste, Waste Management Handbook, Green Action, Zagreb, 11.2007      |
| EEA          | 2007 | The road from landfill to recycling, common destination, different routes |
| Potocnik, V. | 1997 | MSW treatment – world experiences, Zagreb                                 |

- NN 2007 8<sup>th</sup> International Conference on Waste Management,  
Vienna, 11.2007
- NN Naples waste management issue, [www.wikipedia.org](http://www.wikipedia.org)

# Strategy and Implementation Plan for Integrated Solid Waste Management in Tehran

A. Harati, M. R. Azimian

Organization of Waste Recycling & Composting, Tehran-Iran

## Abstract

The Tehran Solid Waste Management Strategy is being developed with the current situation, the current organizational structure and the current operational practices. The waste management organization has done various projects in public awareness, composting etc. The management and operation of solid waste relate to lots of criteria more than the human mind can handle effectively. The reports show integrated view in the solid waste management is the best method for management under multi dimensional situation.

This study focuses on strategy and implementation plan in Tehran for gaining to the best result. With the aim of come to a long term cost effective, sustainable and social/political acceptable solid waste management system, the strategies were developed. The municipality has already defined some high level strategic goals like the 3-R approach. But With the use of SWOT analysis and QSPM, as a decision support system (DSS), it is possible to Process on quantitative methods for choice of strategies in solid waste management and ranks them under spatial criteria. This method has been checked for integrated Solid waste management in Tehran as a case study.

## Keywords

Integrated solid waste management, Strategic management, SWOT analysis

## 1 Introduction

The daily production of solid wastes in Tehran is 7500 tons (min 4000 – Max 11000 t/d) which according to analyses almost %65 is organic materials which can be composted (wet wastes) %32.5 is solid wastes and %2.5 is special household waste and the healthcare waste as almost 40 tons daily. As the waste decays fast it is collected once in 24 hours from the production sources. This method is based on a three years plan. Presently the collection is mechanized by implementing this project the 2 millions point of waste reduced to 70.000 bins which has a good effect on reducing the air pollution. The city of Tehran is, as many multimillion cities, confronted with a steadily increasing population and a consequently increased production of waste. The study area is bounded by the Alborz Mountains (north) and province borders (East, West and south). The Solid Waste Management (SWM) system is challenged to cope with the developments and find a way to manage waste, urban planning, environment and social requirements in a sustainable manner. The proposed 7500 tons per day needs to have

strategic plan as part of well built decision support system (DSS). The documents show that the developments in decision support system begun with building mode- driven DSS in the late 1960s, theory development in 1970s the implementation of financial planning systems spread sheet DSS and group DSS in the early and mid 1980s. Executive information system and business intelligence was evolved in the late 1980s and mid early 1990s. Finally, the chronicle ended with knowledge-driven DSS and the implementation of web- based DSS in the mid 1990s. Also Little identified four criteria for designing models and systems to support management decision-making instead which included: robustness, ease of control, simplicity, and completeness of relevant detail. All four criteria remain relevant in evaluating modern Decision Support Systems. Scott Morton studied how computers and analytical models could help managers to make perfect in key business planning decision. He conducted an experiment in which managers actually used a Management Decision System (MDS). The solid waste management is by far one of the most concerns for governments and municipalities. The strategic management systems play important role in integrated solid waste management in Tehran. This Management is divided to 3 main sections:

- Waste generation
- Collection and transportation to disposal sites
- Disposal methods

The background of solid waste management refers to thousands years ago, human used fertilizer in agriculture. In 1906, engineering approach on solid waste management was presented and some methods to mechanize waste collection were shown. The studies and other experiences show the municipal solid waste management (MSWM) consists of many qualified parameters. Consequently, it's very difficult to choose the best strategy for MSWM under spatial scenarios with uncertainties.

Consequently, this study tries to develop methodological approach on how to perform the Decision Support system (DSS) and strategic management for integrated solid waste management. The next step discusses the DSS capability.

## 2 Materials & Methods

### 2.1 Development of strategic options

Many engineering efforts have developed mathematical methods, fuzzy logic, game theory etc. in DSS model, but there are not clear methods in strategies selection. In order to show quantitative methods of coping with flood hazards and their effects, different strategic alternatives should be defined and ranked. Therefore, the SWOT is appropriate tools to define strategic alternatives with evaluation of the strengths, weaknesses, opportunities and threats in systems. This technique is created by Stanford University in the 1960s and 1970s for business companies; nevertheless there are many similarities between case study systems and companies. In both of them, the strategies are established on strengths, weaknesses, opportunities and threats.

Accordingly, for flood management, SWOT analysis is applied to define strategic alternatives in case study area. Next, the SWOT analysis identifies internal and external factors. The strengths and weaknesses are presented by internal factors. The opportunities and threats are shown as external factors to the case study area. The related strategic options have been summarized in table (1). All strategies have been divided in four main sections. Section 1 belongs to strategies to use maximum opportunities with strength positive potential of case study areas (SO). Section 2, divides some strategies to apply strengths against the threats (ST). Section 3, is for strategies that use opportunities to cover weaknesses (WO). Section 4, minimizes weaknesses and threats (WT). Table (1) shows S, W, O and T in case study area.





Table 2 SWOT analysis for Tehran Solid waste management

Process Strategy					
	Preparation	Primary Processing	Secondary Processing	Final Disposal	
S1	Waste Acceptance	Shredder & Screening	Compost production	Manual Sorting & Screening	RDF
S2		Shredder & Screening	Compost production	Manual Sorting & Screening & Compress	Landfill
S3		Shredder	Stabilize organic material	Compress	Landfill or bio filter
S4		Screening	Compost production	Manual Sorting & Screening & Compress	Landfill
S5		Bag opener & Screening	Compost production	Manual Sorting & Screening	RDF
S6	Landfill for all kind of waste				
S7	Waste Incineration				

In the next steps, the best scenarios are defined and compared with Quantitative Strategic Planning Matrix (QSPM), in this method the best alternatives are chosen based on Strengths, weaknesses, opportunities and threats. The analytical hierarchy process (AHP) is applied to quantify QSPM method.

## 2.2 Quantitative Strategic Planning Matrix (QSPM), to select best scenarios

The integration of management in Tehran is the most important target and DSS methods should be applied with quantitative parameters. This study shows all part of DSS with quantitative methods to achieve this target. Meanwhile the application of strategic management in DSS is assessed. In this section, the scenarios of solid waste management are score and sorted based on QSPM method. The strategic alternatives in Tehran solid waste management are ranked by Strengthens, Weaknesses, Opportunities and Threats. The numerical models are applied upon Analytical Hierarchy Presses. Alternatives are weighted and scored under S, W, O and T criteria by Delphi analysis.

The result has been shown in table (4) and the S5 scenario is the best one with this methods.

Table 3 QSPM method to select best strategic option in Tehran Solid waste management

QSPM	S <sub>1</sub>		S <sub>2</sub>		S <sub>3</sub>		S <sub>4</sub>		S <sub>5</sub>		S <sub>6</sub>		S <sub>7</sub>	
	V	S	V	S	V	S	V	S	V	S	V	S	V	S
<b>Strengths</b>														
Decrease Landfill Operation Cost	3	0.12	4	0.16	2	0.08	4	0.16	4	0.16	2	0.08	4	0.16
Income	4	0.332	3	0.249	2	0.166	3	0.249	4	0.332	3	0.249	2	0.166
Waste Volume Minimization	4	0.04	1	0.01	2	0.02	3	0.03	4	0.04	1	0.01	3	0.03
Save Resource & Material	2	0.02	1	0.01	1	0.01	1	0.01	2	0.02	1	0.01	1	0.01
Energy Production	1	0.06	2	0.12	1	0.06	4	0.24	3	0.18	1	0.06	4	0.24
Soil Protection	3	0.18	4	0.24	2	0.12	4	0.24	4	0.24	3	0.18	3	0.18
Pollution Emission Control	3	0.9	4	1.2	3	0.9	3	0.9	4	1.2	2	0.6	2	0.6
Marketing for recyclable Material	4	0.188	1	0.047	3	0.141	1	0.047	4	0.188	1	0.047	1	0.047
<b>Weaknesses</b>														
Low Quality of Material	1	0.125	1	0.125	1	0.125	1	0.125	1	0.125	1	0.125	1	0.125
Low level of Health Care	1	0.125	1	0.125	1	0.125	1	0.125	2	0.25	1	0.125	1	0.125
Air & water Pollution	1	0.06	1	0.06	1	0.06	1	0.06	2	0.12	1	0.06	2	0.12
High Capital Cost	1	0.08	2	0.16	1	0.08	2	0.16	1	0.08	1	0.08	2	0.16
<b>Opportunities</b>														
Support by Local Government	4	0.2	3	0.15	2	0.1	3	0.15	4	0.2	4	0.2	1	0.05
Employment	4	0.2	4	0.2	2	0.1	3	0.15	4	0.2	3	0.15	1	0.05
Development of Recycle Industries	4	0.5	1	0.125	1	0.125	1	0.125	2	0.25	1	0.125	1	0.125
Decrease Waste Management Costs	4	0.25	3	0.1875	2	0.125	3	0.1875	3	0.1875	2	0.125	2	0.125
Public Participant	3	0.09	1	0.03	1	0.03	1	0.03	2	0.06	1	0.03	1	0.03
Development of Agriculture and Soil Quality	3	0.6	2	0.4	3	0.6	3	0.6	4	0.8	1	0.2	2	0.4
Lack of source separation	4	0.8	4	0.8	3	0.6	4	0.8	4	0.8	2	0.4	3	0.6
<b>Threats</b>														
Problem in Market because of low quality	1	0.03	1	0.03	1	0.03	1	0.03	2	0.06	1	0.03	1	0.03
Illegal Market	1	0.02	1	0.02	1	0.02	1	0.02	1	0.02	1	0.02	1	0.02
Health and Safety	2	0.2	2	0.2	1	0.1	2	0.2	2	0.2	1	0.1	1	0.1
Lack of professional Workers	1	0.0625	2	0.125	1	0.0625	1	0.0625	2	0.125	1	0.0625	1	0.0625
Problem in product because of bad separation	1	0.03	1	0.03	2	0.06	1	0.03	2	0.06	1	0.03	1	0.03
Lack of Tourists Participant	2	0.08	1	0.04	1	0.04	1	0.04	2	0.08	1	0.04	1	0.04
<b>Final Scores</b>		5.2925		4.8435		3.8795		4.771		5.9775		3.1385		3.6255
<b>Ranking</b>		2		3		5		4		1		7		6

### 3 Discussion and result

The results emphasize on integrated solid waste management. Meanwhile the SWOT analysis and numerical methods are useful in solid waste management. SWOT helps managers to choose the best strategic options. Basically, the DSS contain state of objectives, define the criteria and pick the alternatives. The methodology follows hierarchy process and tries to dedicate quantitative approach in all parts of decision support system (DSS). This method shows good adaptation with numerical models. To achieve above mentioned targets, strategic management and DSS tools have been combined together. This method decreases uncertainties with usage of strategic management to define strategic alternatives in case study zone. In this paper, management methods and engineering tools are linked, each phase is quantified and errors in decision making are shown to decreasing. The above mentioned alternatives are scored and ranked by Analytical Hierarchy Process (AHP) based on Quantitative Strategic Planning Matrix (QSPM) according to strategic management methods.

Consequently, S<sub>5</sub> (applying Bag opener and drum Screen to produce compost with manual sorting, secondary screen and production of RDF) is the best strategy for Tehran Solid Waste Management.

### 4 References

- |   |      |  |
|---|------|--|
| Parsons, H. de B.                                   | 1906 | Parsons, H. de B., 1906, the disposal of municipal refuse, 1st ed., Wiley, New York.   |
| Little, J. D. C.,                                   | 1970 | Models and Managers: The Concept of a Decision Calculus. Management Science, 16, 8, B466-485.  |
| Scott Morton, M. S.                                 | 1971 | Management Decision Systems; Computer-based support for decision making, Boston, Division of Research, Graduate School of Business Administration, Harvard University. |
| Tchobanoglous, G., Theisen, H. & Eliassen, R.       | 1977 | Solid Wastes Engineering Principles and Management Issues, McGraw-Hill, 77-102   |
| Power, D. J.  | 2002 | Decision Support Systems: Concepts and Resources for Managers, Westport, CT: Greenwood/Quorum.   |
| Harati S.A.N. Jolous Jamshidi R. Abdollahi Nasab A. | 2006 | Investigation on landfill gas extraction potential from conventional landfills in Iran-Kahrizak case study, Sardinia Symposium, Italy                                  |

- Ali Forouhar, Roger Batstone 2006 Feasibility Study for a Compost Plant at Kahrizak, Organization of waste recycling & composting, Tehran, Iran
- Harati.S.A.N, Ab- 2008 Strategic Management and Decision Support System in Case study Zone, Case Study of solid Waste management in north of Iran, Journal of science & technology, Iran
- dolahzadeh.R, Vafae.F, trategic

**Author's address(es):**

Amir N. Harati  
R&D Manager  
Organization of Waste Recycling & Composting Tehran-Iran  
Tel +98 912 17 57 319  
Email: Haratia@alborz.kntu.ac.ir

Mohammad Reza Azimian  
Deputy of Managing Director  
Organization of Waste Recycling & Composting Tehran-Iran  
Tel +98 912 12 67 675

# **Hazardous waste classification and re-use (end of waste) by New Waste Directive, CLP and REACH Regulations**

**Monika Malicka**

Malex Waste Utilization Company, POLAND

## **Abstract**

Hazardous waste' means waste which displays one or more of the hazardous properties H. Attribution of the hazardous properties H is derived from risk phrases R coming from Directives 67/548/EEC and 1999/45/EC. New CLP Regulation (repealing above Directives) in place of risk phrases R introduces hazard statements H. That means, that soon we will derive hazardous properties H (1 or 2-digit) from hazard statements H (3-digit) of it's components.

New waste hierarchy on a second place put 'preparing for re-use'. On the other side Reach Regulation claims that "end of waste" comes under this regulation. In a consequence a Registration Obligation appears.

These can strongly influence hazardous waste management soon, if nothing will be done.

## **Keywords**

Hazardous Waste, CLP, Reach Registration, ADR, waste re-use, "end of waste",

## **1 Polluter Pay Principle (PPP)**

One of the core principles of sustainable development is the 'Polluter Pay' Principle" which requires that the costs of pollution be borne by those who cause it. Waste and pollution are strictly connected. In waste management systems information about waste can be transferred (from waste holder - producer or previous possessor) or gained from direct waste examination, which can be very expensive and in some cases inadequate to real waste composition. That's why waste producer (polluter) should be responsible for all available and necessary, for further transport and management, information from very beginning.

## **2 Hazardous waste**

A Citation from Directive 2008/98/EC of the European Parliament and of the Council of 19 November 2008 on waste and repealing certain Directives:

Whereas:



(14) The classification of waste as hazardous waste should be based, inter alia, on the Community legislation on chemicals, in particular concerning the classification of preparations as hazardous, including concentration limit values used for that purpose.

Definition (art. 3.2) 'Hazardous waste' means waste which displays one or more of the hazardous properties H listed in Annex III;

Notes (in Annex III)

1. Attribution of the hazardous properties 'toxic' (and 'very toxic'), 'harmful', 'corrosive', 'irritant', 'carcinogenic', 'toxic to reproduction', 'mutagenic' and 'eco-toxic' is made on the basis of the criteria laid down by Annex VI, to Council Directive 67/548/EEC of 27 June 1967 on the approximation of laws, regulations and administrative provisions relating to the classification, packaging and labelling of dangerous substances.

2. Where relevant the limit values listed in Annex II and III to Directive 1999/45/EC of the European Parliament and of the Council of 31 May 1999 concerning the approximation of the laws, regulations and administrative provisions of the Member States relating to the classification, packaging and labelling of dangerous preparations (2) shall apply.

It is a change in comparison with the old definition of hazardous waste, where characteristic of hazardous waste was made on base of hazardous properties H and waste origin and its composition. Now it is possible to receive information that waste is eco-toxic H14, but without knowledge about what kind and amount of constituent gives this hazardous property to this waste.

To establish hazardous properties of waste it is necessary to do some examination (physical properties) and/or to do some calculations based on concentration and risk phrases R attributed to dangerous substances, constituents of waste. These R phrases are taken from classification of chemicals.

## **2.1 Chemicals classification**

On a day of publishing a New Directive on waste, Chemical Directives (67/548/EEC and 1999/45/EC) were still in force, but few days later LCP Regulation was voted through. It entered into force on 20 of January 2009 and stipulates that the classification and labelling of substances must be consistent with CLP on 1 December 2010 and mixtures (former preparations) on 1 June 2015. The old Directives will be totally repealed on 1 June 2015.

## 2.2 CLP

Regulation (EC) No 1272/2008 of the European Parliament and of the Council of 16 December 2008 on classification, labelling and packaging of substances and mixtures, amending and repealing Directives 67/548/EEC and 1999/45/EC, and amending Regulation (EC) No 1907/2006, called CLP Regulation, comes to EU legislation as a result of implementation of GHS UN (United Nation The Globally Harmonized System of Classification and Labelling of Chemicals). The GHS includes: harmonized criteria for the classification of substances and mixtures according to their physical, health and environmental hazards; and harmonized hazard communication elements (including requirements for labels and safety data sheets). GHS is a worldwide compromise and brings to EU system a lot of changes: new hazard classes and categories and its evaluation procedures, new hazard pictograms, signal words, hazard statements H (former risk phrases R, equivalent but not always identical) and precautionary statements P (former safety phrases S). Risk phrases which are essential for waste classification as health hazard and eco-toxicity are concerned are announced as 3-digit H statements and transferred to 2-digit H PROPERTIES OF WASTE WHICH RENDER IT HAZARDOUS. It seems to be a source of many errors and misunderstandings in future. Do we really need it? Maybe it is time to say that hazardous substance/ mixture is also hazardous as it becomes waste and leave the same system for hazard communication.

## 2.3 REACH

Regulation (EC) No 1907/2006 of the European Parliament and of the Council of 18 December 2006 concerning the Registration, Evaluation, Authorisation and Restriction of Chemicals (REACH), establishing a European Chemicals Agency, amending Directive 1999/45/EC and repealing Council Regulation (EEC) No 793/93 and Commission Regulation (EC) No 1488/94 as well as Council Directive 76/769/EEC and Commission Directives 91/155/EEC, 93/67/EEC, 93/105/EC and 2000/21/EC says that registration is compulsory for the manufacturer or the importer of a substance in quantities at or above than 1 Mg per year. It is decided, no registration - a ban on a turnover. One substance – one registration. That means that all producers and manufactures of a substance join together (SIEFS) and put forward one registration document to ECHA (European Chemicals Agency). In this dossier physicochemical, toxicological, eco-toxicological properties of a substance (with the methodology of all measurements) and classification should be given. If a substance is produced in quantities at or above 10 Mg per year (or identified as PBT – persistent, bioaccumulative, toxic), Chemical Safety Report is necessary and exposure scenarios for identified use should be proposed.

Generally REACH Regulation declares that waste don't come under this law, as far as they are waste. Recovered substances from 'end of waste' products should be pre-

registered and then registered (that was official opinion from REACH helpdesk in November 2008). This interpretation made a lot noise in the world of waste management companies. Doc: CA/24/2008 rev.3 Follow-up to 5th Meeting of the Competent Authorities for the implementation of Regulation (EC) 1907/2006 (REACH) (Concerns: Waste and recovered substances) gave some hope:

Once recovered substances cease to be waste, they are again subject to REACH obligations but can also benefit from a number of exemptions. Article 2(7) (d) of REACH provides the following exemption:

“Substances, on their own, in preparations or in articles, which have been registered in accordance with Title II and which are recovered in the Community if:

(i) the substance that results from the recovery process is the same as the substance that has been registered in accordance with Title II; and

(ii) the information required by Articles 31 or 32 relating to the substance that has been registered in accordance with Title II is available to the establishment undertaking the recovery.” (ref. SDS – safety data sheet and exposure scenario if necessary).

Summarizing – to run off from REACH registration: the sameness of the substance must be proofed and legal SDS of registered substance must be shown. Without help of waste producers waste management companies can't do it. Re-use process (which stands on a second place in waste hierarchy now) via REACH registration process won't be economically justified.

### 3 List of Waste (LoW)

The European List of Waste (LoW) comes from Commission Decision 2000/532/EC1 with the later amendments. ‘The LoW serves as a common encoding of waste characteristics in a broad variety of purposes like transport of waste, installation permits, decisions about recyclability of the waste or as a basis for waste statistics’. That is a quotation from Review of the European List of Waste (Final Report). Executive Summary by Ökopol GmbH in cooperation with ARGUS GmbH (November 2008).

Is that a truth? Partly, yes, as waste statistics and permits are considered. The List of waste is only partly useful as we talk about a transport and recyclability of hazardous waste. The different types of waste in the List are fully defined by a 6-digit code, with two digits each for chapter, sub-chapter and waste type. If a code of waste is accompanied with asterisk that means that this type of waste is hazardous. From more than 900 types of waste (in Poland) nearly half of them are considered as hazardous. About one fourth of hazardous waste types from LoW are described with words ‘containing dangerous substances’. These are mirror entries hazardous waste. Dangerous sub-

stance can be dangerous because of: toxicity, eco-toxicity, flammability and all other existing hazards. As far as is not known exactly what kind of dangerous substances are constituents of waste any transport classification or recyclability evaluation is not possible. To be able to do it an information about this substance quality (for instance its SDS) and its quantity is wanted. It can happen one more unpleasant surprise. For some codes: for instance 06 05 02\* sludges from on-site effluent treatment containing dangerous substances, a few different transport codes can be assigned in a result of ADR classification procedure (depending on a quality and a quantity of dangerous substances in waste). Saying straightforward behind the same code can stand chemically absolutely different mixtures.

## 4 Basic Characterisation of waste

COUNCIL DECISION of 19 December 2002 establishing criteria and procedures for the acceptance of waste at landfills pursuant to Article 16 of and Annex II to Directive 1999/31/EC (2003/33/EC) enters new document – Basic Characterisation of waste. Basic characterisation is the first step in the acceptance procedure and constitutes a full characterisation of the waste by gathering all the necessary information for a safe disposal of the waste in the long term. Basic characterisation is required for each type of waste.

Fundamental requirements for basic characterisation of the waste is listened below:

- (a) Source and origin of the waste
- (b) Information on the process producing the waste (description and characteristics of raw materials and products)
- (c) Description of the waste treatment applied in compliance with Article 6(a) of the Landfill Directive, or a statement of reasons why such treatment is not considered necessary
- (d) Data on the composition of the waste and the leaching behaviour, where relevant
- (e) Appearance of the waste (smell, colour, physical form)
- (f) Code according to the European waste list
- (g) For hazardous waste in case of mirror entries: the relevant hazard properties according to Annex III to Council Directive 91/689/EEC of 12 December 1991 on hazardous waste (2)
- (h) Information to prove that the waste does not fall under the exclusions of Article 5(3) of the Landfill Directive

- (i) The landfill class at which the waste maybe accepted
- (j) If necessary, additional precautions to be taken at the landfill
- (k) Check if the waste can be recycled or recovered.

Looking on it, it is more less SDS for waste. But why it becomes necessary in the very last stage of life cycle of waste. This document should start as waste appears at a waste producer place and grow with every step of a waste management.

## **5 Carriage of hazardous waste (ADR)**

European agreement concerning the international carriage of dangerous goods by road (ADR) is part of EU internal law by Directive No 94/55/EC of 21 November 1994 on the approximation of the laws of the Member States with regard to the transport of dangerous goods by road. A Hazardous waste is a dangerous goods if transport by public roads is realized.

By ADR (according to the words of this agreement):

The term “dangerous goods” shall mean those substances and articles the international carriage by road of which is prohibited or authorized on certain conditions by Annexes A and B:

### Annex A

- classification of goods, including classification criteria and relevant test methods;
- use of packagings (including mixed packing);
- use of tanks (including fillings);
- consignment procedures (including marking and labelling of packages and placarding and marking of means of transport as well as documentation and information required);
- provisions concerning the construction, testing and approval of packagings and tanks;
- use of means of transport (including loading, mixed loading and unloading);

### Annex B

- requirements for vehicle crews, equipment, operation and documentation;
- requirements concerning the construction and approval of vehicles.

### Responsibilities

How than, practically, hazardous waste can be transported – according to the rules which can be extracted from Annexes A and B as soon as hazardous waste receives UN number and PG packaging group. Who is responsible for that?

According to ADR (1.4.2.1.1) – The consignor of dangerous goods is required to hand over for carriage only consignments which conform to requirements of ADR. ....in particular:

(a) ascertain that the dangerous goods are classified and authorized for carriage in accordance with ADR...

In the waste world it means a waste producer. So why legal permits for the hazardous waste generation consist only of these waste codes saying nothing about UN and GP even, when it is declared that they are taken away to waste management places via transport ?

In SDS for chemicals in 14 sections is place for transport information – class ADR, UN number and PG.

## 6 Occupational Safety and Health

Occupational health and safety is a cross-disciplinary area concerned with protecting the safety, health and welfare of people engaged in work or employment. The goal of all occupational health and safety programs is to foster a safe work environment. In the European Union, member states have enforcing authorities to ensure that the basic legal requirements relating to occupational health and safety are met. In 1996 the European Agency for Health and Safety at Work was founded.

What about waste management? Sometimes it seems that there are no human beings working with waste. Hazardous waste are signed with code of LoW (XXXXXX\*) and nothing more. Even if hazardous properties H of waste are known there are no warning signs connected with them. In my practice I “borrow” a hazard communication signs from systems prepared for chemicals and work strictly according to information from SDS to provide my employers with proper individual protection measures.

## 7 Summary

To summarize my observations I dare to put forward some proposals which can join hazardous waste management with the world of safe work, economical efficiency and sustainable development:

1. Hazardous waste classification is done in the same way as it is defined in CLP Regulation for substance/mixtures. System of hazard communication is also the same.
2. Basic characterisation and ADR classification of waste starts with the first waste appearance according to PPP (polluter pays principle) and grows with every step of waste management. Information about waste must submit “occupational safety and health” demands.
3. A full documentation on waste gives right to ‘re-use’ as product -‘end of waste’ without REACH Registration process.

### **Author’s address**

PhD.-Eng. Monika Malicka  
Malex Waste Utilization Company  
23 Wenera rd.  
Poland 91-169 Lodz  
Tel.(48)(42)7164410  
Email [monika.malicka@malex.lodz.pl](mailto:monika.malicka@malex.lodz.pl)  
Website [www.malex.lodz.pl](http://www.malex.lodz.pl)



# Improvement of hazardous waste management in Turkey through introduction of a web-based system for data collection and quality control

Volker Küchen

ARGUS GmbH, Berlin, Germany

## Abstract

The Waste Framework Directive (WFD) requires the Member States to take the necessary measures to ensure that waste is properly recovered or disposed of. To improve the management of hazardous waste in Turkey, the project LIFE06 TCY/TR/292 'HAWAMAN' was conducted in co-operation of the Turkish Ministry of Environment and Forestry (MoEF) and the GTZ from 2007 to 2009. The project covered several measures required by the WFD, including an inventory on the amounts of hazardous waste generated by industrial facilities. ARGUS, on behalf of GTZ, was responsible for the introduction of a web-based record system for the inventory on hazardous waste and a monitoring system, which included modules for data quality control and reporting. For reference year 2008 more than 1/3 of all facilities representing more than half of all employees recorded in the business register participated. Moreover, a large number of companies became aware of their duty to identify and record their hazardous waste.

## Keywords

Hazardous waste, LIFE, Inventory, Turkey, Monitoring, Data collection

Türkei, gefährliche Abfälle, Inventar, Überwachung, Datenerhebung

## 1 Introduction

The Waste Framework Directive (WASTE FRAMEWORK DIRECTIVE, 2008) specifies certain measures to ensure that waste is recovered or disposed of in accordance with Article 13, i.e. without endangering human health or harming the environment. Specific measures laid down in the WFD include the introduction and common use of appropriate classification systems (LoW: Art. 7; recovery and disposal codes: Annex I and II), the principle of producer responsibility (Art. 14, Art. 15), the issue of permits for waste treatment facilities (Art. 23), the drafting of waste management plans (Art. 28), the requirement that the actors of waste management shall be subject to appropriate periodic inspections (Art 34) and their obligation to keep records on their activities (Art. 35).

It can be seen that several of the above measures require the recording of information on the amounts of waste generated by quantity, type, origin and destination (including treatment operation type and capacity).

Turkey as a candidate country had, in recent years, been beneficiary of some European funded projects aiming at the improvement of waste management and the implementation of the EU legislation on waste. Two twinning projects were conducted between 2004 and 2008, aiming at the implementation of more than ten EU directives focussing on the general management of waste (packaging directive, landfill directive) and of other particular categories of waste (directives on waste oils, batteries & accumulators, PCBs and end-of-life vehicles). Focussing on the management of hazardous waste, the project "Improvement of Industrial Hazardous Waste Management in Turkey" (LIFE06 TCY/TR/292 'HAWAMAN'), in the following been referred to as LIFE project, was conducted in co-operation of the Turkish Ministry of Environment and Forestry (MoEF) and the Deutsche Gesellschaft für Technische Zusammenarbeit (GTZ) between January 2007 and April 2009.

The project covered most of the measures laid down in the WFD as mentioned above, particularly the performance of an inventory on hazardous waste, the provision of guidance on the hazardous waste classification based on the List of waste (LoW), a concept on hazardous waste management and check-lists for the inspection of recovery and disposal facilities in the context of the permission procedure. These tasks were supported by measures of capacity building through guidance documents and trainings.

ARGUS with its extensive experience in the performance of waste surveys, data validation and analysis as well as the conception and development of databases was responsible for the activities related to data collection and management, i.e. the introduction of a record system for the inventory on hazardous waste from industrial facilities and the introduction of a monitoring system, which included modules for data quality control, reporting and inspection.

ARGUS provided the conceptual work for the adaptation and development of the database systems and the hazardous waste inventory, performed the data evaluation after the surveys and actively participated in the setup of the business and facility registers as well as the classification tables required for data collection and monitoring. Moreover, ARGUS provided an important communication link between the IT experts and programmers on the one hand and the technical department of MoEF and the other involved technical experts on the other. In the following, the related activities and results are described.

## 2 Development of survey and database concepts

### 2.1 Initial situation

The Turkish regulation on the control of hazardous wastes (REGULATION ON THE CONTROL OF HAZARDOUS WASTES, 2005) requires the industry to supply waste data for the annual inventory/data survey. The waste generators have to send the filled-in questionnaires for their hazardous waste record each year in April for the previous calendar year. In the past this was done by paper form sheets sent from the industry, which were manually digitalised by the administration in order to be usable for reporting and monitoring purposes. For reference year 2006 the MoEF collected the data via a questionnaire using a MS Excel form sheet. These systems did not permit the actual validation of data, did not produce applicable results within an appropriate time frame and overburdened the administration with work. Only a small percentage of the Turkish companies had sent their form sheets in the previous years (about 600 companies in 2006).

In order to conduct these surveys more efficiently and improve data quality, the idea for a web-based electronic waste data record system was expressed by MoEF and the Turkish Statistical Institute (TURKSTAT) in 2005 already, when a framework agreement between both institutions was signed. This cooperation led to the development of a first prototype of a waste record system for MoEF which was programmed by TURKSTAT on the basis of the MS Excel questionnaires and presented to MoEF and the LIFE project in the middle of 2007.

Apart from the reporting obligation of the waste generators, the Turkish regulation on the control of hazardous wastes requires the waste treatment operators to deliver monthly reports on the amounts treated (waste mass balance forms) and detailed records of the amounts from the consignment notes of the transports delivered to their site (national waste transportation forms). The collection of these data is still conducted largely by using paper or electronic questionnaire formats. At the time of the LIFE project, a web-based collection was already prepared and a prototype for data entry was developed but the system was not fully implemented.

### 2.2 Definition of system requirements

ARGUS conducted a feasibility study with a comparison of three database systems existing at MoEF and TURKSTAT which could serve as a HWRS (including the central environmental information system at the MoEF). The comparison revealed that the prototype programmed by TURKSTAT was the best system to be adapted for the development of a HWRS. The prototype offered good structural opportunities to collect the data required by the waste department in one comprehensive data base and to run the

distinct applications needed. In addition, TURKSTAT was an experienced partner to carry out waste data collection surveys of such extent and offered appropriate technical and professional support.

ARGUS specified the technical requirements and the definitions for the HWRS and described the following elements required for a suitable HWRS:

- The business register section, which keeps the main data of the waste generators (name, location, NACE code, tax number, number of employees etc.). The basis to start the register had to be retrieved from external sources (see section 2.3.2).
- The facility register section, which keeps the main data of the recovery and disposal installations, such as name, address, licence code, licensed capacities and waste codes as well as the recovery and disposal code of the operation on the basis of Annex I and II of the WFD, as ratified in the Turkish regulation. Here, the content had to be supplied and maintained by MoEF.
- The waste data section, which keeps the raw data of each annual survey on waste amounts and types (6-digit LoW codes), measuring unit and recovery and disposal facility. They are directly accessible by the province administration for their respective province. MoEF has access to all data nationwide.
- The classification section, which keeps the hazardous waste list, based on the European LoW, the list with recovery and disposal codes and the regional classification according to the European NUTS levels (which is also used by TURKSTAT for reporting of data according to the Waste Statistics Regulation).
- The entry mask for password-restricted access by the waste generators, which allows the industry to enter and correct its data discretely. Several features facilitate the use of the system (pull-down menus on waste codes and links to the facility register to select the appropriate installation by mouse click, etc).

Apart from the structural requirements, the responsibilities for data collection and evaluation during the survey were defined by ARGUS in cooperation with MoEF. As a consequence, different user rights with different levels of access to the data from the database were proposed to be implemented in the HWRS in order to grant applicability and security at the same time. Figure 1 shows the responsibilities for data collection. Note that all data are entered and managed in one central database and that the symbols on provincial and local level merely represent those parts of the central database that are accessible at these levels, not separate client databases.

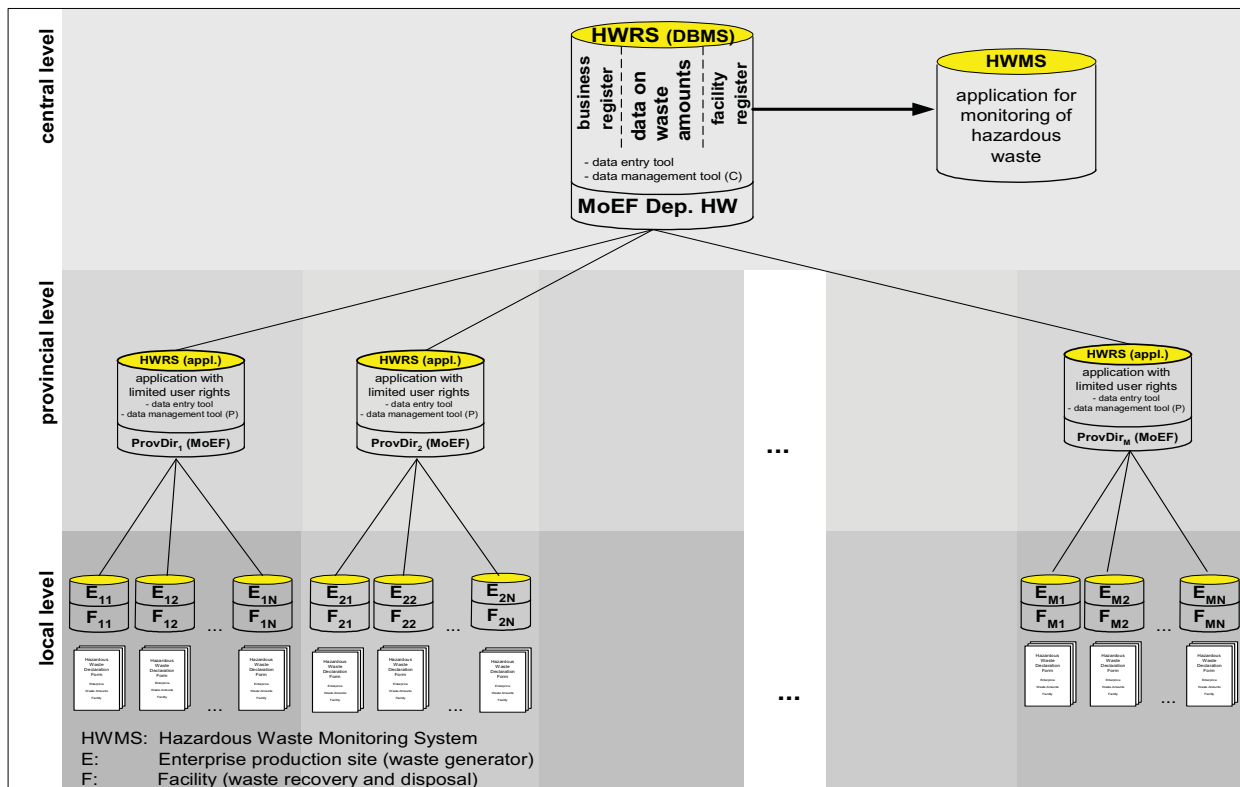

Figure 1 Organisational structure of data collection

As illustrated in Figure 1, the data collection takes place at the local level of the individual production sites of companies. A representative of the site has the right to read, enter and edit only the local data. The province departments shall conduct an evaluation of the data collected from the companies within their province. They get a management tool to view the waste generation data of their province, identify non-reporters and they can delete or enter companies to the business register, including the creation of additional user IDs and passwords. The only system user with full access to all national data is the hazardous waste division of the MoEF. It can access the data either by logging into the HWRS or by entering the application for monitoring of hazardous waste (HWMS) which was introduced in the further process of the LIFE project.

The purpose of the HWMS is to support the hazardous waste division at the MoEF to monitor and manage its administrative tasks efficiently, to fulfil the requirements of the hazardous waste regulation, to fulfil the reporting obligations towards national requirements and towards the European Union and to strengthen the data processing system of MoEF in general. The specific objectives of the HWMS are the creation and implementation of:

1. a data quality assurance system, safeguarding complete and reliable data;
2. a reporting and publication system, safeguarding information distribution from a central data source on a high quality level and without time delay; and

3. a control system for supporting recurrent tasks of the Hazardous Waste division, to save manpower for core tasks.

The data quality assurance system (1) should be designed to validate the data collected with the HWRS for missing and implausible data and to perform some essential transformations (conversion from volume to mass unit). Thus, the data quality assurance system can be regarded as a tool that assists the hazardous waste division in the preparation of a validated and corrected annual data set from the collected raw data.

In the reporting and publication system (2) mainly generates reports with typical aggregations of the waste data as required for regular reporting and publication or for replies on ad-hoc requests from senior staff. The reporting system also generates compilations for planning purposes (e.g. amounts of the provinces by source).

The control system (3) is a tool that serves to compare the amounts reported by the waste generators with the licensing data of the facility (capacity, recovery and disposal codes, LoW codes) and with data reported by the facilities themselves (waste mass balance forms / national waste transport forms).

The control system shall contain an additional module for the recording of inspections by means of the check-lists developed under another task of the LIFE project. The check-lists cover typical aspects that should be controlled during a site visit at recovery and disposal facilities as well as waste producers. The additional application module shall contain an electronic version of the check-lists and shall allow direct access to the data from the facility register and the business register. So the province level at MoEF can use and share real-time information on facilities and companies with the central level. Another benefit is that the information on the company/facility is available for the inspection prior to the control visit in a time saving and unified form. During control visits by province staff these base data can be updated together with the company/facility by logging in to the web-based application.

The monitoring system had to be designed for application with other relevant databases at MoEF, including the application for special waste and the waste section of the existing environmental information system (EIS). This was necessary to guarantee the sustainability of the programmed modules and to make the integration of the system into the EIS possible. This integration was particularly important for the business and facility registers, as these data are used by other departments of the MoEF.



## **2.3 Setup of registers**

### **2.3.1 Facility register**

In MoEF all staff members of the hazardous waste division were used to manage licensing data by their own standards. This had to be changed by common rules and a unified format for data supply in the facility register. ARGUS checked the facility register data and aligned them in order to transfer them from Excel-based data sheets into a data base format. The standardisation of the facility data proved to be a lengthy and difficult process, especially as almost every week new facilities were licensed and consequently added to the list.

These facility data are under supervision of MoEF and have to be kept in a structure, which has to be applicable with other relevant databases operational at MoEF. The alignment of structures to secure integration with the existing data base structures, e.g. the environmental information system (EIS) and the GIS applications at MoEF, was pursued by ARGUS so that the data content could be shifted without difficulty. For this reason a close cooperation with the IT department of MoEF was necessary under moderation of ARGUS.

### **2.3.2 Business register**

Data on industry and employees are required for the business register. They were only available at TURKSTAT or at the Union of Chambers and Commodity Exchanges of Turkey (TOBB). The industry data / business register available at TURKSTAT was still under development at the time of the first survey. Therefore, the business register of TOBB for 2007, which contained about 65.000 establishments, was used as the basis for the HWRS and the HWMS.

Prior to its usage, the register was processed by ARGUS to exclude all establishments which were regarded by the LIFE project team and MoEF as not yet relevant, either because of their economic activity (e.g. services) or because of their size (units with less than 10 employees). The remaining information on about 38.000 establishments was used as the basis for waste data collection by the HWRS for reference year 2007.

Further steps towards a sound business register were undertaken in the course of the two surveys performed. In the process of the first survey on 2007 data, the province departments updated the list with about 3.000 additional facilities not registered before. In addition, prior to the second survey on 2008 data, the province departments voluntarily performed a major quality control of the business register, resulting in the reduction of the register from about 41.000 to about 38.000 sites mostly from removal of production sites that were closed. The review was a great improvement as it was the first major



review of the list. This improved business register was then used as the basis for the survey on 2008 data in the beginning of 2009.

### **3 Introduction of the systems**

The TURKSTAT IT department programmed the HRWS including the entry masks and additional menus and created user IDs and passwords. The system was introduced to the users and stakeholders in March 2008. Representatives of all 81 provinces and about 70 associations, chambers and other relevant institutions and companies were invited. Almost all 130 staff members, who were invited, participated in the event. A representative of the German Federal Ministry for the Environment, Nature Conservation and Nuclear Safety and the General Director of MoEF opened the meeting.

Representatives of the MoEF and TURKSAT demonstrated the electronic data input in detail. ARGUS presented and explained the general and specific requirements of waste data surveys. All provinces received a CD with HWRS access details to be distributed to the waste generators in their province. The representatives of the industry associations and chambers were requested to spread their knowledge to the industry. Figure 2 shows the user interface of the HWRS.

As shown by the frames in Figure 2, the user interface consists of three parts as follows:

1. Company data from the business register
2. Waste data (small frame: summary table of waste data already entered)
3. Data on responsible person

Part 1 is partly pre-filled. Parts 2 and 3 are blank when the company enters the system the first time.

**TEHLİKELİ ATIK BEYAN SİSTEMİ**

**1. İşletme ile ilgili teknik bilgiler**

Vege Kimlik Numarası : 12345678 **identification No.**

İş yerinin adı : golhan ltd sti **facility name**

İl adı : MANİSA **province,** İlçe adı : AKHİSAR **sub-province etc.**

Bucak adı : PALAMUT **sub-province etc.** Köy adı : BURNUS

Mevki : Dışçılar

Mahalle : Huzur Mahallesi **address (street, number etc.)**

Cadde / Sokak : 19.Sok

Dış Kapı : ? İç Kapı : 1

Posta Kodu : **postal code, telefon, fax, e-mail** Telefon Numarası :

Faks Numarası : Elektronik Posta :

1. İşyerinizde 2006 yılında ortalama çalışan sayısını yazınız : 1291 **number of employees**

2. İşyerinin ana faaliyet konusunu belirtiniz : 2022 **economic branch code (NACE)**

**2. Tehlikeli atık tablosu**

**treatment location (internal/external/export)**

Atık kodu	Atık yağ kat.kodu	Ölçü birimi	Miktar	Bertaraf/Geni Kazanım İşleminin nerede yapıldığı	Uygulanacak işlem	İşlem kodu	Tesis kodu
<b>waste code (waste type)</b>	<b>unit</b>	<b>amount</b>	<b>recovery/disposal (R&amp;D) type</b>	<b>R&amp;D facilities</b>			
<input type="text"/>	<input type="text"/>	<input type="text"/>	<input type="text"/>	<input type="radio"/> Tesis içinde(TI) <input type="radio"/> Tesis Dışında(TD) <input type="radio"/> İhracat(H)	<input type="radio"/> Geni Kazanım(GK) <input type="radio"/> Nihai Bertaraf(B)	<input type="text"/>	<input type="text"/>

**3. Sorumlu Personel:**

Adı :  **responsible staff:**

Soyadı :  **name/surname**

Ünvanı :  **position**

Figure 2 User interface of the HWRS

From May to August 2008 the coordination and integration with the different databases into one joined application system were discussed based on the proposals of ARGUS. In the end the registers were fully integrated with the environmental information system (EIS). On this basis, the terms of reference for tendering and contracting a company to programme the HWMS were prepared. In August 2008, Stratek Stratejik Teknolojiler Ar-Ge was contracted on account of the LIFE budget. In the beginning of December 2008, the programming finished on time and on 18th of December, training on HWMS was conducted by MoEF and ARGUS.

In February 2009, ARGUS compiled the terms of reference for the additional module for the recording of inspections by means of electronic check-lists. The contracting proce-

ture for programming commenced in March 2009. The programming of this addition was finalised in April 2009.

## **4 Conducting of the surveys 2007 and 2008**

In the course of the LIFE project, ARGUS could assist MoEF in the performance of two survey on hazardous waste covering the reference years 2007 and 2008

The first electronic data collection and inventory on hazardous waste 2007 was conducted from April to June 2008. In these three months, the province departments did not succeed to notify more than 60% of the about 38.000 companies identified. One reason here is that provinces like Istanbul or Kocaeli, which had to address more than 10.000 companies, could not keep up with the work load. In addition, 3.000 companies not registered yet had to be added to the business register in this period.

As a consequence, many companies had not received their access data on-time, so that it was decided to grant the densely industrialised provinces additional time for notification and to re-open the electronic data collection from September to November 2008 for a second round of data input for reference year 2007.

The second survey was conducted with the new data collection tool in the last months of the LIFE project. From February to April 2009 the system was opened for the survey for reference year 2008, after the major review of the business register by the province departments (see section 2.3.2).

When the surveys were finished, the validation and rough analysis of the raw data for reference years 2007 and 2008 were conducted by ARGUS. The results are briefly summarised in section 5 below.

During the surveys, MoEF staff had to answer numerous requests by companies. They were claiming to be unable to supply data because they were unaware of producing hazardous waste. Often MoEF needed to inform the companies about possible waste production in their industrial branch. Many companies could not classify hazardous waste from non-hazardous waste or were not familiar with the recovery and disposal methods. Others had to be told that even waste, which is sold by them because of its positive market value, still has to be classified and reported as waste.

## **5 Results of the surveys 2007 and 2008**

After the conclusion of the surveys ARGUS performed a preliminary data analysis on company response rates and a validation aiming at the identification of missing and im-

plausible data, that require correction. For internal use at MoEF, ARGUS produced some preliminary aggregations of waste amounts by province, LoW chapter and recovery and disposal method.

Table 1 shows the results for the coverage of the surveys 2007 and 2008. The data in the row "response" show the number of companies, and the respective sum of employees represented, which registered to the system and updated their company data. As a part of these companies claimed to generate no hazardous waste, the third line represents the number of companies who had entered their waste data.

*Table 1 Response rates by number of firms and employees for the surveys 2007 and 2008*

Type of data provided	No of companies		Share from total		No of employees		Share from total	
	2007	2008	2007	2008	2007	2008	2007	2008
No data	33.496	25.299	80%	66%	1.512.411	1.074.618	62%	45%
Response	8.120	13.153	20%	34%	944.894	1.315.078	38%	55%
of which provided waste data	4.275	6.032	10%	16%	727.330	888.304	30%	37%
<b>Total</b>	<b>41.616</b>	<b>38.452</b>	<b>100%</b>	<b>100%</b>	<b>2.457.305</b>	<b>2.389.696</b>	<b>100%</b>	<b>100%</b>

It can be seen that for year 2008, roughly 38.500 companies were listed in the system (approximately 3.000 fewer than for 2007 due to the review of the business register), of which about 13.200 (34 %) had entered the electronic system and supplied detailed data on their company (2007: 8.100; 20 %). Ca. 6.000 (16 %) of these companies recorded their waste data (2007: 3.600; 10 %).

Thus, the response rate based on number of companies has greatly improved during the inventories on 2007 and 2008 data and largely exceeded that of previous years prior to the introduction of the HWRS (about 600 companies delivered their MS Excel questionnaires in 2006).

If the number of employees is considered, the companies who responded represent 55 % (2007: 39 %), with a corresponding share of 37 % (2007: 30 %) with waste data. Thus, the response rate related to employees improved significantly compared to 2007 and exceeded half of all employees registered in the HWRS system, which is very satisfactory.

The total number of records requiring correction decreased from 3.670 in 2007 to 2950 in 2008, i.e. by one third. At the same time, the total number of waste records increased from 10.360 to 16.500, i.e. by 40 %, resulting in a considerable reduction of the total share of errors to only 17 % of all records (2007: 35 %). In the two years, more than 70 % of all errors were missing entries for treatment facilities.

As these errors can only be resolved by consultation of thousands of companies involved, the required data corrections have not been performed for the data 2007 and 2008 due to the high work load of the MoEF and its provincial directorates. According to a decision of the hazardous waste division at the MoEF, a comprehensive consultation of the companies aiming at the correction of missing and implausible data is only envisaged for the data of 2009 and later. For this reason, the waste amounts can not be presented.

## **6 Conclusions and Outlook**

The LIFE project successfully developed a data collection and management solution for Turkey. The rapid increase of data supply by the industry has demonstrated high acceptance of the hazardous waste record system in the companies. An important effect of the survey was that the awareness of the companies on their duties stipulated by the regulation on control of hazardous waste was strongly increased. For the first time, waste generators were notified directly by the authorities to classify and register their hazardous waste through the supply of individual access codes which enabled them to report their waste electronically.

The voluntary effort of the province departments to further improve the business register for each province proved, that the benefits were well understood and the system is regarded as useful. In addition, the province departments have a new and more important role as they are in charge of checking the inventory for non-reporters and data errors and notifying the affected companies in their province. These activities have had a large impact on Turkish industrial waste producers, as many understand now, that their non-reporting is not going unnoticed by the authorities.

Even in many Member States the environmental and the statistical administration collect environmental data separately at the same sources/stakeholders and report them independently of each other. With the support of the LIFE project, the MoEF and TURK-STAT strived to cooperate and collect one set of hazardous waste data from industry, which may then be shared by both institutions for their different purposes. This is a unique and innovative approach and has not been tried in many MS so far. It is supporting the waste producers in their efforts to comply with legal environmental requirements and reduces the burden especially for small and medium size enterprises. Both institu-

tions have shared their specific expertise. TURKSTAT contributed its experience in large-scale data collection and validation, MoEF its capacity with regard to technical and organisational aspects of waste management, e.g. its specific knowledge of the existing recovery and disposal facilities licensed by the hazardous waste division.

For the improvement of industrial hazardous waste management this is a very important step forward though the way to complete coverage and correct data in Turkey is still a long one. Data validation and interpretation remains a challenge for the future, as the data collected in the course of the LIFE project were the first two comprehensive datasets on hazardous waste.

The hazardous waste record system and the coordinated waste data collection initiated by the LIFE project is transferable to other countries inside, but also outside of the EU. The IT department of the Egyptian Environmental Affair Agency recently studied the Turkish HWRS system and aims to transfer it with adaptation for their own hazardous waste data collection system.

## 7 Literature

- |   |      |  |
|---|------|--|
| Waste Framework Directive                     | 2008 | Directive 2008/98/EC of the European Parliament and of the Council of 19 November 2008 on waste and repealing certain Directives, OJ L 312, 22.11.2008, p. 3 |
| Regulation on the control of hazardous wastes | 2005 | Regulation on the control of hazardous wastes (Original title: Tehlikeli Atıkların Kontrolü Yönetmeliği) of 14 March 2005, Official Journal No. 25755        |

### Author's address

Dipl.-Ing. Volker Küchen  
 ARGUS GmbH  
 Einemstr. 20a  
 D-10785 Berlin  
 Telefon +49 30 3980 6013  
 Email: [kuechen@argus-statistik.de](mailto:kuechen@argus-statistik.de)  
 Website: [www.argus-statistik.de](http://www.argus-statistik.de)



## **DIRECT-MAT – developing best practice on recycling or safe disposal of road materials in Europe**

**Konrad Mollenhauer<sup>1</sup>, Maria Arm<sup>2</sup>, Yannick Descantes<sup>3</sup>,  
Knud A. Pihl<sup>4</sup>, Laszlo Gaspar<sup>5</sup>, Luc De Bock<sup>6</sup>, Jean-Baptiste Gobert<sup>3</sup>,  
Chantal de la Roche<sup>3</sup>**

<sup>1</sup> TU Braunschweig, Institut für Straßenwesen, Braunschweig (ISBS), Germany,

<sup>2</sup> Swedish Geotechnical Institute (SGI), Sweden, <sup>3</sup> Laboratoire Centrale des Ponts et  
Chaussées (LCPC), France, <sup>4</sup> Danish Road Institute (DRI), Danmark, <sup>5</sup> Institute for  
Transport Sciences (KTI), Hungary, <sup>6</sup> Belgian Road Research Centre (BRRC), Belgium

### **DIRECT-MAT –Wiederverwendung, -verwertung und sicherere Entsorgungs- Technologien für Straßenausbaustoffe in Europa**

#### **Abstract**

DIRECT-MAT is a three-year European project aiming to develop best practice on dismantling and recycling or safe disposal of road and road related materials at the European level. It was initiated within the EC 7<sup>th</sup> Framework Transport Research Program and is comprised of partners from fifteen participating countries for a budget of 1.2 million Euros. The project runs through 2009–2011 and involves building a European Web database and drafting best practice guides on Dismantling and RECYcling Techniques for road MATerials (“DIRECT-MAT”). Several materials are addressed – unbound, hydraulically bound and asphalt road materials, but also other materials related to road use but not commonly recycled in road construction. These include tyre shreds, sediment from ditches, industrial by-products and reinforcement materials. As a first project result the paper presents a summary of reuse, recycling and disposal strategies for the addressed road materials.

#### **Inhaltsangabe**

Bei Rückbau und baulicher Erneuerung von Straßenbefestigungen fallen große Mengen an Straßenausbaustoffen an. Durch deren Wiederverwertung im Straßenbau kann das Abfallaufkommen sowie der Verbrauch von neuen Baustoffkomponenten erheblich reduziert werden. Um die Wiederverwertung von Ausbaumaterialien aus Fahrbahnbefestigungen Europaweit zu fördern und vorhandene Technologien allen Mitgliedsstaaten verfügbar zu machen, wurde im 7. Rahmenprogramm der Europäischen Kommission ein mit 1,2 Mio. € gefördertes Forschungsprojekt initiiert (DISmantling and RECYcling Techniques for Road MATerials – DIRECT\_MAT). Seit Anfang 2009 werden zunächst die vorhandenen Technologien im Bereich des Baustoffrecyclings im Straßenbau zusammengestellt und in einer Online-Datenbank frei zugänglich gemacht.

#### **Keywords**

Recycling-Baustoffe, Straßen-Ausbaustoffe, Fahrbahnbeton, Asphalt

Recycling, road materials, road concrete, asphalt



# 1 Introduction

The European road network has a total length of more than 5.8 million km (ERF 2007) and it is still growing. Obviously, various pavement layers exhibit different lifetimes which makes regular maintenance work necessary. As a result, several hundred million tons of road materials are excavated each year from a number of demolished pavement layers. According to European policy (EUROPEAN PARLIAMENT, 2006), these materials can be seen as wastes, viz. “substance or object which the holder discards or intends or is required to discard”. Nevertheless, in nearly all countries, part of these road construction wastes is reused or recycled back into road infrastructure and this part may reach 100 % depending on the type of road waste. Furthermore nearly all countries have developed their own strategy to handle road material wastes in terms of characterisation, demolition, classification, handling, recycling and reuse technology. In this way even some beneficial effects of road material waste reuse were discovered, such as natural resource savings (e.g. aggregates, bitumen) as well as improved road materials behaviour. Available information is being either unpublished or published in native languages, very few countries can benefit from actual breakthrough. In order to improve the situation, a research project called DIRECT-MAT was proposed for the 7<sup>th</sup> framework research program in order to initiate the knowledge transfer between the stakeholders within the European Member states.

## 1.1 Background

The EU25 main road network is essential for passenger and freight transportation across Europe. However, its maintenance is costly and also responsible for detrimental impacts to the environment relative to waste production and natural resource consumption. As emphasized by ERTRAC in its Research Framework (ERTRAC, 2006), it is necessary to simultaneously optimise the quality-to-cost ratio of road infrastructure and encourage environmentally friendly road maintenance practices. A significant contribution to the ERTRAC view consists of reducing the proportion of road materials originating from natural resource extraction and increasing the recycling of locally-available road wastes into new road materials.

Over the past few years, most European countries have started to work towards this goal, by implementing national strategies for dismantling and recycling road materials back into new roads. At present, many European countries have acquired experience in dismantling and recycling road and road related materials back into roads, especially asphalt materials, either on their own or by applying European research results.

However, depending on available wastes and local regulations, the practice at national level differs significantly from one country to another. Thereby, a wide array of research

results on road material recycling has been produced, yet they are dispersed throughout the various Member States and not widely implemented. Furthermore, pertinent databases and available documents usually are not translated into a common language and site data are seldom available to specialists from other countries. As a result, national experience based on local site data almost never benefits other European countries, and this especially affects the newer Member States.

## **1.2 Objectives of DIRECT-MAT**

At present, many European countries have acquired experience in dismantling and recycling road and road related materials back into roads, especially asphalt materials. However, research results are not widely implemented and national documents are not often available to specialists from other countries. In this European project, twenty partners cooperate to build a web database that will provide access to validated guidelines, national document references, harmonised literature reviews and practical application case studies based on jobsite data sets.

By gathering information on every type of road and road related material used along with local experiences, by drafting best practice guides and sharing all those elements on a website, the DIRECT-MAT project will establish a benchmark on the best practices for dismantling and recycling or safe disposal of road and road related materials. The work undertaken will also serve to identify further possible research needs for improving overall system optimisation with regard to material dismantling, manufacturing and implementation processes.

Thus DIRECT-MAT will actively contribute to generate closer cooperation between research and practice within road material recycling and also contribute to reducing the waste disposal associated with roads.

## **1.3 DIRECT-MAT Research Consortium**

Twenty partners – research institutes, universities and private companies – from fifteen participating countries will contribute collecting, analysing and sharing international as well as national information for the benefit of Europe (Table 1).

Table 1 Partners in the DIRECT-MAT Consortium

Partner	Country
French Public Works Research Laboratory (LCPC), Coordinator	France
Belgian Road Research Centre (BRRC)	Belgium
Swedish Geotechnical Institute (SGI)	Sweden
Danish Road Institute (DRI)	Denmark
National Laboratory for Civil Engineering (LNEC)	Portugal
Dresden University of Technology (TUD)	Germany
Braunschweig Institute of Technology (TUBS/ISBS)	Germany
Institute for Transport Sciences (KTI)	Hungary
National Institute of Applied Science (INSA) Strasbourg	France
University College Dublin (UCD)	Ireland
Recipav/Recipneu	Portugal
Forum of European National Highway Research Laboratories (FEHRL)	-
Branchevereniging Recycling Breken en Sorteren (BRBS)	Netherlands
The Research Institute of VÖZ	Austria
Transport Research Centre (CDV)	Czech Rep.
Swedish National Road and Transport Research Institute (VTI)	Sweden
Centro de Estudios y Experimentación de Obras Públicas (CEDEX)	Spain
Slovenian National Building and Civil Engineering Institute (ZAG)	Slovenia
The Highway Institute (IP)	Serbia
Road and Bridge Research Institute (IBDiM)	Poland

## 1.4 Organisation of work

The work programme is organised into seven work packages where four packages focus on the various construction materials, one is devoted to the database and the remaining two work packages to management & coordination and dissemination (comp. Figure 1).

Dissemination activities include cooperation with a Reference Group consisting of end users in several countries; presentations in national and international papers and conferences as well as the arrangement of national seminars and a European workshop for end users in 2011. Continuous project information will be available at <http://direct-mat.fehrl.org>. Potential end users of the DIRECT-MAT project results are road owners, standardization experts, road designers, contractors, material producers, researchers, laboratory personal, professional associations, equipment manufacturers as well as teachers in professional education.

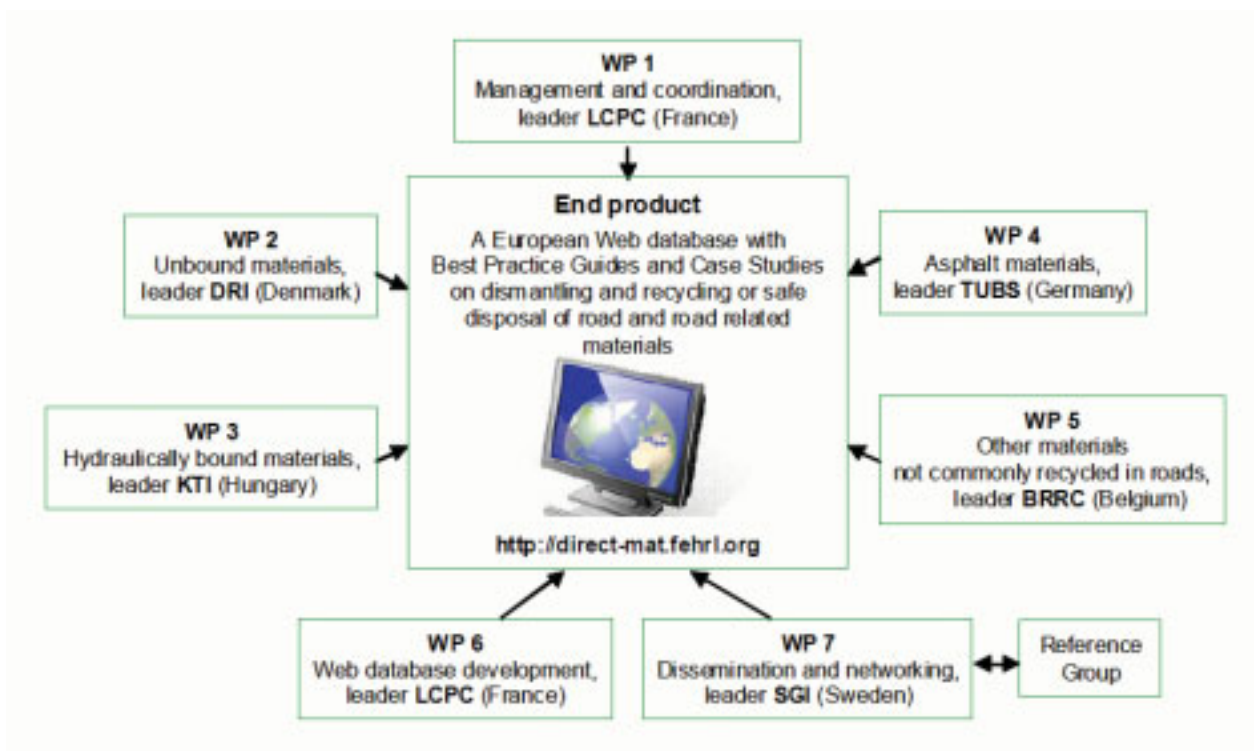

Figure 1 DIRECT-MAT work package organisation

## 2 Road waste materials addressed in DIRECT-MAT

In the Direct-Mat project the major road materials demolished during maintenance activity are addressed in single work packages. There the national techniques for demolition and recycling were elaborated during 2009.

### 2.1 Unbound materials

Unbound materials built up the base of any road. On top of the natural soil, which may be modified already with hydraulically binders, the roadbase is built up from natural aggregates (sand, gravel or crushed rock). Besides load-spreading properties the unbound base layers enable a drainability of the road structure as well as prevent frost heave especially in northern Europe. Therefore unbound road material consists of a mixture of the natural aggregates with varied grain sizes. In order to achieve the drainability the unbound material mixtures are composed specifically. Each grain itself needs high resistance against crushing to prevent the development of fines which would disturb the technical workability of the construction layer.

With thicknesses up to 50 cm the unbound materials take the highest percentage of the volume of a road structure.

As a first result of the international literature review as well as of the evaluation of the national material standards and recommendations it can be summarised that demol-

ished unbound layers can be reused in new road construction courses. Therefore the recycled material must fulfil the same technical requirements as natural aggregates in terms of single grain properties as well as the resulting grading. Therefore recycled aggregates are often mixed with virgin material to reach the needed material composition.

As new unbound layers are often drained and come in contact with groundwater several countries define environmental requirements on the recycled road material. If the recycled material contains special target pollution its use is restricted to waterproof road structures and may be prohibited in water protection areas.

## **2.2 Hydraulically bound materials (coming from roads)**

The application of concrete pavements in road constructions is used to various extents in Europe's nations. For example, in 2008 there were only 101 km of concrete roads in use in Hungary and only 87 km in Sweden. In Austria by contrast 38 % (1420 km) of the highly trafficked motorways are made of concrete and up to 70 % of new motorways are currently built with concrete. Hydraulically bound pavement layers have been used in the form of concrete pavements and cement bound base layers in Denmark while cement stabilisation of sub-grade was never applied to any considerable extent.

These examples show the wide range of application of concrete pavements in Europe. Similar disparities can be noticed in the field of concrete recycling.

Recycling of materials has become normal practice in countries like Austria and Belgium where concrete pavements are used in a high percentage of the road system. In these nations (Austria, Belgium and the Czech Republic) special organisations are dealing with this technique and representing the national recycling companies. The use of recycled road materials in cement concrete pavements can not be considered as a common technology in other countries like Hungary. However there are several valid specifications in this field available. In Slovenia research on recycling of concrete roads was mainly focused on the use of industrial by-products like steel slag, fly ash and crushed concrete from building demolition in new concrete. Hydraulically-bound waste from road construction has not been targeted in European research works by now; the main reason can be that this waste usually utilized at least as material for embankment.

## 2.3 Asphalt materials

Throughout Europe about 333 million tonnes of hot mix asphalt (HMA) were produced in 2008 by more than 3.000 asphalt companies (EAPA 2008). At the same time more than 51 million tonnes of reclaimed asphalt were made available for recycling due to road maintenance or demolition.

The DIRECT\_MAT participating countries look back on different developments concerning the road industry determined by natural circumstances (size of country, population, traffic density and natural recourses). These differences cause various answers concerning the development of recycling techniques for road materials.

An overview about various recycling techniques is given in Figure 2. Before the old flexible pavement is demolished the material is characterised. If it contains substances involving a danger for health or the environment (e.g. tar) special recycling techniques are necessary which are addressed in WP 5.

Generally two techniques can be applied on asphalt pavements:

- in-situ recycling where the old pavement material remains on site after being processed using mobile equipments and
- plant recycling where the dismantled road material is transported to mixing plants.

Demolition of the old pavement can be done using 2 methods: milling or cracking to blocks. In situ recycling generally requires milling. After demolition further manufacturing steps are applied to reach reclaimed asphalt which can be used in new pavement layers. The application in unbound layers is further addressed in WP 2.

With both recycling techniques, the reuse of the reclaimed asphalt (RA) in situ or in plant can be divided into:

- hot recycling where RA is mixed with new aggregates and hot bitumen, laid and compacted as usual hot mix asphalt at temperatures around 150°C (HMA),
- warm recycling where RA is mixed with new aggregates and hot bitumen with the addition of additives which enable the reduction of the mixing, laying and compaction temperature (~100°C),
- cold recycling where RA is mixed with new aggregates and bitumen emulsion or foamed bitumen with the possible further addition of hydraulically binder if required (~20°C).

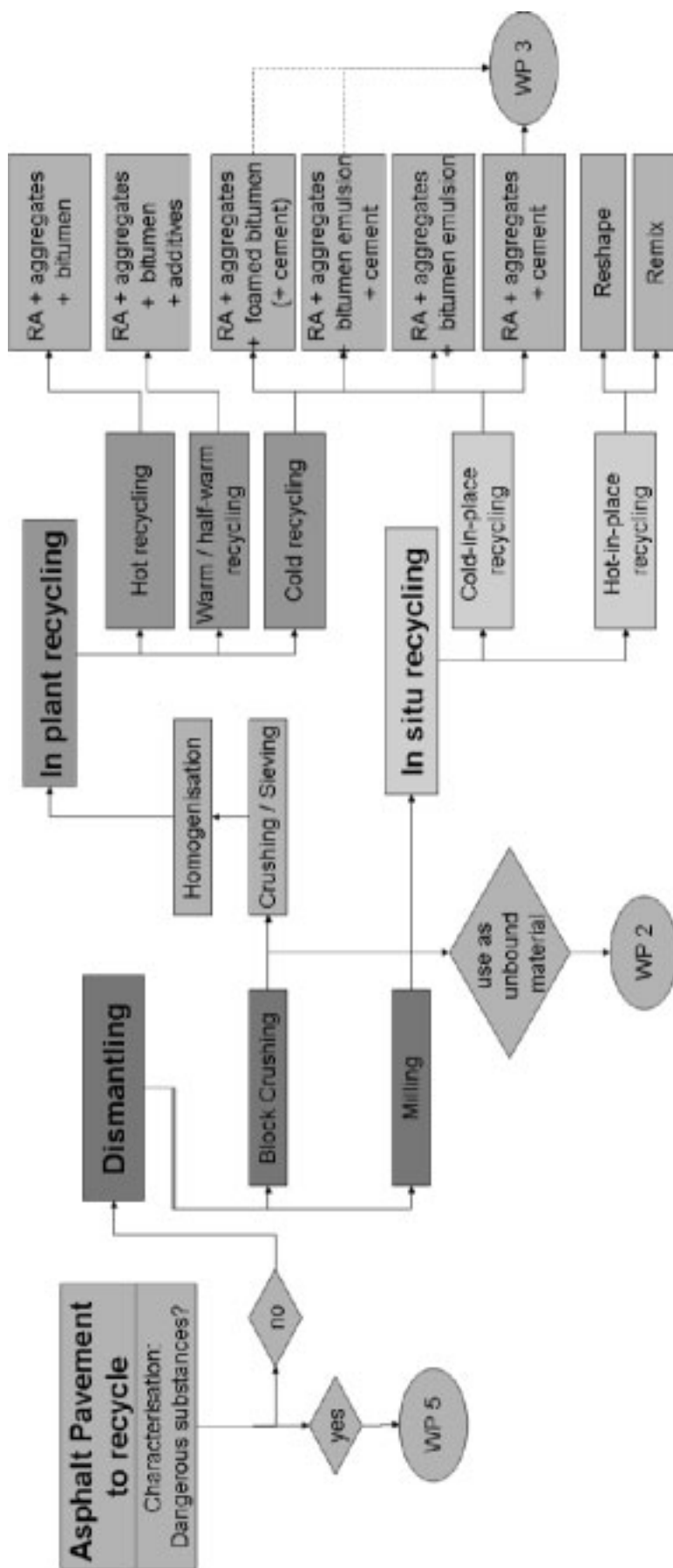

Figure 2: Techniques for recycling of reclaimed asphalt



Figure 3 shows the differences in the applied techniques for the end-of-life strategies for asphalt roads. Whereas some countries focus on the recycling of reclaimed asphalt as unbound material in road base layers, others specialised in the reuse of the old bituminous bound material in new hot mixed asphalt. In both cases the material from roads having reached the end of their service life is recycled in new road structures and high recycling rates are reached.

The causes of these differences can be found in differences of the general infrastructure in the various countries. Some countries have a high population density more or less homogeneously spread whereas others have wide areas with low population. Therefore some countries have a high number of stationary mixing plants which enables the plant-recycling by avoiding long-distance transportation of material. In these countries the percentage of plant-recycling is comparably high. Countries with areas of low population-density have a road network with less heavy trafficked roads which enables the application of in-situ recycling techniques where long-distance material transportation is avoided.

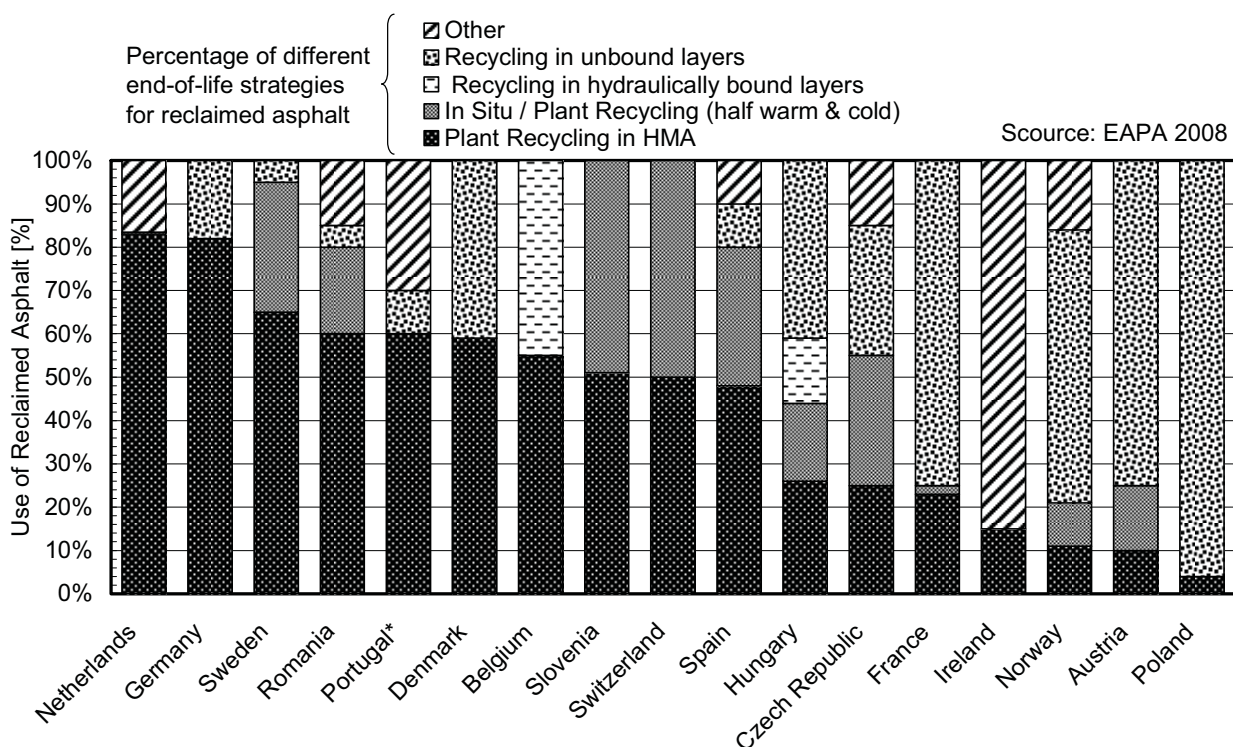

Figure 3: Use of reclaimed asphalt material in road recycling (EAPA 2008 / \*2007)

## 2.4 Other road waste materials

Besides the major 3 groups of road construction materials (unbound, hydraulically bound and asphalt) there are some other materials used in road constructions which are not bulk goods or may need special consideration during road maintenance work.

Reinforcement materials (steel anchors, geosynthetic grids, etc.) and road markings interfere with common milling procedures and their residues may have to be removed from the reclaimed material.

In the past some road materials were used which were found to contain hazardous substances (as tar or asbestos). Other materials are subjected to traffic pollutants during their lifecycle (road shoulder materials). For both types of material their unrestricted re-use in the road construction is prevented due to health and safety or environmental issues.

The various end-of-life strategies for these materials vary considerably. One specific example is the handling of tar-bonded road materials. In several countries tar made of coal was used as asphalt binder until its carcinogenic hazards were discovered. Many road pavements still contain tar in some of their layers. When demolished nearly all countries developed special treatments for characterising the road waste and moreover for the recycling of these materials. In Germany, tar-containing material can be used as new cold-bound road construction material if it is ensured that leaching is prohibited (e.g. below waterproof road layers) (FGSV 2007). Other strategies range from the deposition in special landfills up to the incineration. This technique is applied in the Netherlands whereby the heated and “clean” aggregates are used directly for the hot-mix asphalt production.

A further road-related material is addressed in WP 5. Several countries benefit from the use of tyre shreds as constituent material in asphalt were found. By the recycling of this material countries will benefit by the reduction of other end-of-life strategies with higher environmental impact (as the energetic recycling in cement plants) as well as by extended service-lifetimes of new roads.

### **3 Summary**

The on-going European research work on the demolition and recycling of road materials is following a systematised programme for its final output, the compilation of a Best Practice Guide in the topic. Not only the synergic experiences of the 20 partners from 15 European countries are utilized but further information coming from other European and non-European countries. The project partners are convinced on the basic advantages of the future outcome of DIRECT-MAT project in attaining a more and more sustainable European highway network.

## 4 Acknowledgement

This project has received funding from the European Community's Seventh Framework Programme (FP7/2007-2013) under grant agreement no 218656. The presented results are based on the project-internal national reports of all participating beneficiaries.

## 5 References

- |                                      |      |  |
|--------------------------------------|------|--|
| ERF (European Union Road Federation) | 2007 | European Road Statistics 2007. ( <a href="http://www.irfnet.eu/images/stat/2007/ERF_stats2007.pdf">http://www.irfnet.eu/images/stat/2007/ERF_stats2007.pdf</a> )   |
| ERTRAC                               | 2006 | European Road Transport Research Advisory Council (ERTRAC) 2006. ERTRAC research framework 2006 ( <a href="http://www.ertrac.org">http://www.ertrac.org</a> )  |
| EAPA                                 | 2008 | European Asphalt Pavement Association 2008, Asphalt in Figures ( <a href="http://www.eapa.org/START/AIF/EAPA-AsphaltinFigures2008.pdf">http://www.eapa.org/START/AIF/EAPA-AsphaltinFigures2008.pdf</a> )   |
| European Parliament                  | 2006 | Directive 2006/12/EC of the European Parliament and of the Council of 5 April 2006 on waste  |
| FGSV                                 | 2007 | Forschungsgesellschaft für Straßen- und Verkehrswesen (FGSV) 2007. Merkblatt für die Verwertung von pechhaltigen Straßenausbaustoffen und von Asphaltgranulat in bitumengebundenen Tragschichten durch Kaltaufbereitung in Mischanlagen M VB-K. Ausgabe 2007. Köln |

### Author's address:

Dr.-Ing. Konrad Mollenhauer  
TU Braunschweig  
Braunschweig Pavement Engineering Centre  
Intitut für Straßenwesen (ISBS)  
Pockelsstr. 3  
D-38106 Braunschweig  
Telefon +49 531 391 2396  
Email: [k.mollenhauer@tu-bs.de](mailto:k.mollenhauer@tu-bs.de)  
Website: [www.tu-bs.de/isbs](http://www.tu-bs.de/isbs)

# Legal requirements and practice of the transport of healthcare waste within European Union

Karine Brück & Pedro Ramalho

The Athisa Group, Granada, Spain & Biotask, Lisbon, Portugal

## Abstract

This article analyses the main characteristics of the legal system set up to transport hazardous healthcare waste by road within the European Union. It is based mainly on the “European Agreement on Transport of Dangerous Goods by Road” (ADR) and on the „Basel Convention on the Control of Transboundary Movements of Hazardous Waste and their Disposal“, which have been incorporated to European and Members’ States law.

The article explains how in practice transfers between Spain and Portugal function and the effective working of the whole system, even though the administrative divisions of Spain complicate the system.

## Keywords

Healthcare waste transport – ADR - Basel Convention – transfer of waste

## 1 Introduction

Transport of healthcare waste moves enormous quantities within European Union every year and is regulated by European and international legislation on the transport of hazardous goods, according to the classification established internationally by UNO. From a legal point of view, two international instruments have been incorporated in European Law to regulate this sector. The first is the “European Agreement on Transport of dangerous goods by road”, known as ADR according to its French initials, incorporated into European Law by the means of the “Council Directive 94/55/EC of 21 November 1994 on the approximation of the laws of the Member States with regard to the transport of dangerous goods by road”. This legal instrument establishes safety requirements that transport, loading and unloading of this kind of merchandise must respect and is applied in 46 countries. It entered into force in 1957 and is subject to biennial review. For international road transport, the current version is 1 January 2009 and from July 1, 2009 it has been applied to transportation within the members states of the European Union. The second is the Basel Convention on the Control of Transboundary Movements of Hazardous Wastes and their Disposal which came in force in 1992 and which has been incorporated into European Law by the means of Council Regulation (EEC) N° 259/93 of 1 February 1993 on the supervision and control of shipments of waste within, into and out of the European Community. This Convention has been adop-

ted by 173 countries around the world and its main aims are to avoid illegal shipping of hazardous waste, mainly to developing countries and to Eastern Europe, to minimize the transboundary movement of hazardous waste, ensure that such wastes are controlled and disposed of respecting the environment, as close as possible to their source of production and to minimize production of hazardous waste at source.

## 2 The “European Agreement on Transport of dangerous goods by road” (ADR)

This agreement has a much broader implementation than just the European Union territory and its main concern is to ensure the safety of transport of dangerous goods by road. It also implements the transport of hazardous waste in general and the transport of healthcare waste within European Union, in particular in accordance with the principles of environmental protection and standardization of existing rules allowing free movement within the EU of this type of waste. Security requirements to promote safe transport of hazardous waste can be grouped into 3 categories: requirements regarding packaging and labelling of this waste; conditions relating to vehicles and finally conditions about drivers. Moreover, some general precautions according to the type of roads used and speed must be respected and the „traceability“ of waste must be fulfilled. **Fehler! Es ist nicht möglich, durch die Bearbeitung von Feldfunktionen Objekte zu erstellen.**

### 2.1 Requirements regarding packaging and labelling

The classification system of ADR dangerous goods is based on the Recommendations on the Transport of Dangerous Goods drafted by the United Nations Committee of Experts on the Transport of Dangerous Goods and published in a document known as the "Orange Book" (colour of its cover.) This system, designed to be applied globally to all modes of transport, categorises goods into nine different classes according to the main type of danger that may arise during transport (explosive, toxic, flammable, infectious, etc.). Each class corresponds to a series of specific protection measures. Among these are:

**Class 6.1 Toxic substances:** Toxic substances which are liable to cause death or serious injury to human health (solid toxic disinfectants, toxic liquids, pesticides, etc.)

Table 1 Classification of Hazardous Waste

	<b>Hazardous Materials</b>
	<b>Class 6.1: Poison</b>

**Class 6.2: Biohazardous substances;** the World Health Organization (divides this class into two categories: **Category A:** Infectious; and **Category B:** Samples (virus cultures, pathology specimens, used intravenous needles)

Table 2 Classification of Hazardous Waste

	<b>Hazardous Materials</b>
	<b>Class 6.2: Biohazard</b>

In healthcare waste sector, these 2 classes correspond to the 2 main types of hazardous medical waste that exist: chemical waste (class 6.1.) which represent less than 10% of the dangerous healthcare waste generated into the hospitals (basically expired medicines, formol, xylol, etc.) and biohazardous waste which represent approximatively 90% of the hazardous medical waste. Moreover, hazardous substances to be legally transported must be identified by their UN number and the trailers which transport these goods must be marked using this four-digit UN number. This identification enables competent authorities in the different countries to know the material transported and how to act in case of accident because these goods must be transported with their specific Safety Data Sheet. Medical waste with number UN 3291 (Waste or reusable material derived from medical treatment of animals or humans, or from biomedical research, which includes the production and testing of biological products) and moreover must have a specific packaging. The marking and labelling must be indicated on all packages containing dangerous goods.

In daily practice, healthcare waste managers use a colour code to identify easily the type of medical waste in the containers used, similar to the picture below. As containers are normally found in the different services of the health centres and hospitals, the training and use for staff in segregation of the waste is simplified to ensure correct and efficient management.



*Figure 1 Coloured containers for medical waste*

In Portugal and parts of Spain, containers normally used for receiving healthcare waste and for transporting it according to all European and international standards are 60-litre-reusable containers used for all hazardous health care waste, except sharp objects for which “one-use specific containers” of different capacities are used. Reusable green, yellow or red 60-litre-containers (the coloured code normally used in Spain and Portugal) are certified for Class 6.2. of ADR and for classes 18.00.00 of the European Waste List. They are totally cleaned and disinfected and can be put into the different services of the hospitals and/or in the central deposit (according to the waste characteristics and production in the services). Their manufacture is subject to E.C. rule (DIN-V-30739) and they are rigid, leak-proof containers, capable of retaining liquids and passing the following tests: falls, leak-proof, internal (hydraulic) pressure, stacking, perforation resistant.

These containers are disinfected in the treatment plant where wastes are sterilized. Waste which has normally to be incinerated must be transferred to France or Germany where the process is carried out; the choice of the country depends basically on the price of this service.





Figure 2 Container for medical waste

Packaging for use with clinical waste has to comply with the requirements of P621. Dangerous goods shall be packed in good quality packaging and healthcare waste is included in Group II Packaging, specific for materials presenting moderate danger. The containers must be strong enough to withstand any normal shocks during transport, including transshipment between transport devices or between transportation and warehousing as well as the removal of the pallet or overpack with a view to a subsequent manual or mechanical handling. Packaging shall be constructed and closed when waste is prepared for shipment in order to prevent any loss of content that might be caused under normal conditions of transport, by vibration or temperature variations, humidity or pressure (due to, for example, the altitude). Packaging shall be closed in accordance with information provided by the manufacturer. These provisions apply, as appropriate, to new packaging, reused, reconditioned or remanufactured and new, reused, repaired or rebuilt and new packaging.

Except as otherwise stated in the ADR, the UN number corresponding to the goods, preceded by the letters "UN" must appear clearly and durably marked on each package transported. In the case of unpackaged objects, the mark must appear on the object itself in its cradle or on its handling, storage or release device.



Figure 3 Barcode and label for identification of the packages

Besides all the information required for transport, waste managers add a label with a barcode on all the containers. This label allows the service where waste has been produced, production date, weight of waste, etc to be identified. With the labelling of the containers, it is possible to identify the "quality" of the segregation in production sites (afterwards, it is possible to know the exact origin of one specific container) and it is possible, with the training of the health care professional to improve segregation and to reduce the production of hazardous health care waste directly at its origin.

## 2.2 Requirements regarding vehicles

The regulation requires a physical separation between the driving cockpit and the cargo area, parking lights, fire extinguishers in the cabin and outside, a deposit of water to allow hand washing, a system for securing the load, a protected electrical system: all connections in a box, battery isolator switch (in the cabin and the engine), an independent lighting in the loading area, orange number plates, a box of tools, etc...technical requirements are numerous. From a practical standpoint, the vehicles must meet all the conditions imposed, have passed the technical inspection to receive the approval to transport dangerous goods under ADR. So a first examination of this authorization is sufficient to determine if a vehicle meets the standards set out in the transport of hazardous medical waste.

## 2.3 Requirements regarding drivers

They must possess a professional certificate for driving dangerous goods issued by the competent authority following the completion of a technical course and practical exercises. The crew must know how to use fire-extinguishing apparatus. During transport, smoking is prohibited in vehicles and their vicinity. It is forbidden to carry passengers except the crew in vehicles carrying dangerous goods. Again, the accent is on safety.

## 2.4 General precautions and “traceability” of waste

Precise speed limits, time restrictions, mandatory routes using the prevailing motorways and ring roads, parking restrictions, restrictions on movement in road tunnels ... are imposed by the legislation.

All these elements must be taken into account when the integral healthcare waste manager is elaborating the circuit to collect the waste produced in the different hospitals and healthcentres to transport them to the treatment plant and final disposal. Moreover, in practice, we must stress the importance of management in real time with satellite location of the lorries working to choose the itineraries. These new technologies permit immediate optimization based on the variable parameters that may occur during the transport circuit. This new management tool can be very important and to help diminish risks, problems and costs.

The other important aspect is to be able to follow healthcare waste all the way, not only during transport but also „from the cradle to the grave“. For this reason, apart from the specific labelling with barcodes, as we have seen above, the Basel Convention procedure of notification will be used if there is a transfer of healthcare waste which involves 2 countries.

# 3 The “Basel Convention on the Control of Transboundary Movements of Hazardous Wastes and their Disposal”

## 3.1 General principles

We have seen that ADR determines the rules of security mainly for vehicles, packaging and transport and the Basel Convention establishes rules to control, transboundary movements and disposal of hazardous waste for human health and the environment when at least two States are involved in the movement at international level.

The premise of Basel Convention is that no waste can be exported if the importing state has not given consent in writing to the specific import of such wastes.

Information about proposed transboundary movements must be reported to the States concerned by a notification form, so they can assess the implications for human health and the environment of the proposed movement. The principles of proximity, priority for recovery and self-sufficiency at Community and national levels are applied. Regulation (EEC) No 259/93 with effect from 12 July 2007 was replaced by Regulation (EC) No 1013/2006 from European Parliament and the Council of 14 June 2006 on shipments of waste [Official Journal L 190 of 12.07.2006]. The regulation applies to almost all types of waste except mainly radioactive waste that has its own control system. The Regulations set out two different transfer control procedures: The first known as "green list" applies to non-hazardous waste destined for recovery and it requires only that information be given to the competent authority. The second is the notification procedure, which applies to all transfers of waste for disposal and hazardous waste for recovery. When healthcare waste is to be disposed of, the procedure used is notification. This procedure requires that the competent authorities of the countries involved in the shipment (country of origin, countries through which the waste transit and destination countries) give their consent before any transfer. To ensure the proper functioning of the single European market, the notice need to be sent only by the notifier to the competent dispatching authority, which is responsible for transmitting the notification to the competent destination and transit authorities. These authorities must give their consent (with or without conditions) or objections within 30 days. The transfer of waste requires a contract between the person in charge of transferring the waste and the recipient of such waste. This contract must be accompanied by financial guarantees in case of transfer of medical waste as in the case of all waste subject to notification requirement.

### 3.2 Practice

From the entry into force of the new framework Directive 2008/98/EC, through article 19, this regulation will be applied to transport of dangerous waste within a Member State. This is an innovation for Portugal where competent authorities are centralized in the Portuguese Agency for Environment (Division of Waste and Contaminated Soils) but not so much for Spain because of its administrative organization. Spain is divided into 17 autonomous regions or "communities" which are already obliged to prepare documents for transfer as if each region crossed were an independent country. Regulation on medical waste is different depending on the region. There is no general rule about the classification of medical waste in hospitals or for treatment systems and disposal permits, even though Law 10/1998, of April 21, on Waste (BOE n°. 96, April 22, 1998) apparently standardizes the sector in the country. Some areas accept incineration, some not, single use containers are required, for example, in Catalonia, while the reusable one is the rule in Andalusia. Each different region requires proper transport and management authorisations and each Community has to have its own treatment facilities to

implement the self-sufficiency principle. Although there is a national plan on hazardous waste, there are, however, 31 different regional plans related to this matter.

## 4 Conclusions

Inevitably, the legislation imposes considerable costs on the integrated healthcare waste management. It is therefore essential that managers not only understand the regulation in detail but seek to arrange an efficient and effective system that fulfills the demands that society makes in such a sensitive and important matter. Moreover, private companies involved in this sector have developed a whole strategy to trace the healthcare waste from the moment of its production until its safe final disposal. Further to the framework directive, the European Union, through the implementation of international regulations has developed a whole body of legal requirements which combines obligations that reinforce transport safety, environment and health protection and the functioning of the single market. It succeeds in finding the balance between these apparently antagonistic aims regulating the system throughout Europe to the benefit of us all.

### Author's address(es) :

Ing. Dipl.-Pedro Ramalho  
Biotask, Bio-technology Solutions  
Parque Empresarial de Torres Vedras. Lote A1  
Ar 9 Paúl  
2560-383 Torres-Vedras (Portugal)  
Telefon +351 965 00 55 73  
Email: [pramalho@eco-task.com](mailto:pramalho@eco-task.com)

LL.B. (Liège), LL.M. (Brussels) Karine Brück  
Grupo Athisa  
Periodista F.J. Cobos, 18 Edificio Camposol, 1-1°C  
18.014 Granada (Spain)  
Tel: + 34 629 90 20 12  
Email: [karinebruck@yahoo.es](mailto:karinebruck@yahoo.es)  
Website: [www.athisa.es](http://www.athisa.es)

# Plastic Flows from Production to (optimal) Recycling

Roland Fehringer

denkstatt GmbH, Vienna, Austria

## Abstract

Total plastic flows in Austria have increased between 1994 and 2004 by 40 % to 3.7 Mio tons. In 2004 the consumption of plastics amounted to ca. 161 kg/capita. The situation in waste treatment has changed significantly. The quantity of plastic waste directed for recycling increased from approx. 50.000 tons in to 130.000 tons and for thermal treatment from 71.000 tons to 564.000 tons. Main driver was not the packaging ordinance but the landfill ordinance. The situation in Poland in 2004 is similar to the situation in Austria 1994. 40 % of plastic waste is collected separately. High rates of mechanical and feedstock recycling and energy recovery are implemented in Austria. Bioplastics do not have a big potential to save greenhousegas emissions. A Sustainability Assessment for different waste management options is necessary.

## Keywords

Plastic flows, Austria, Poland, Separate Collection, Material Recycling, Feedstock Recycling, Bioplastics, Greenhousegas Emissions, Sustainability Assessment

## 1 Introduction

During the last 50 years, plastic materials have become one of the most important types of materials used in various branches. Due to their special features, i.e. low weight, availability and costs, they have substituted or replaced many traditional materials and are at present widely applied in short- and long-life products. They are dominating the packaging market, and are more and more commonly used in automotive and building sectors. Therefore, assessment of plastic flows and their appropriate management, in accordance with the objectives of sustainable development, has recently become an important issue in modern societies, worth more comprehensive investigations.

## 2 Plastic Flows in Austria 1994 / 2004 and in Poland 2004

In a study conducted by the Austrian Environmental Agency and undertaken by the Vienna University of Technology, Institute for Water Quality, Resource and Waste Management, consumption and waste generation of plastic materials in Austria have been assessed for the year 1994 (FEHRINGER & BRUNNER, 1997). It is shown how plastic consumption grew up in time, how stocks of long-life plastic materials in use increased considerably, and how large amounts of plastic wastes resulted from the consumption pattern. Ten years later ARGEV Verpackungsverwertungs-Ges.m.b.H. conducted an up-



date of this study and a comparison with actual situation in Poland. The three data sets are used to compare the evolution of plastic flows and stocks over time, and to assess potential differences in the plastic management in both countries (BOGUĆKA & BRUNNER, 1997). Figure 1 shows plastic flows and stocks in Austria in 1994 and Figure 2 in 2004.

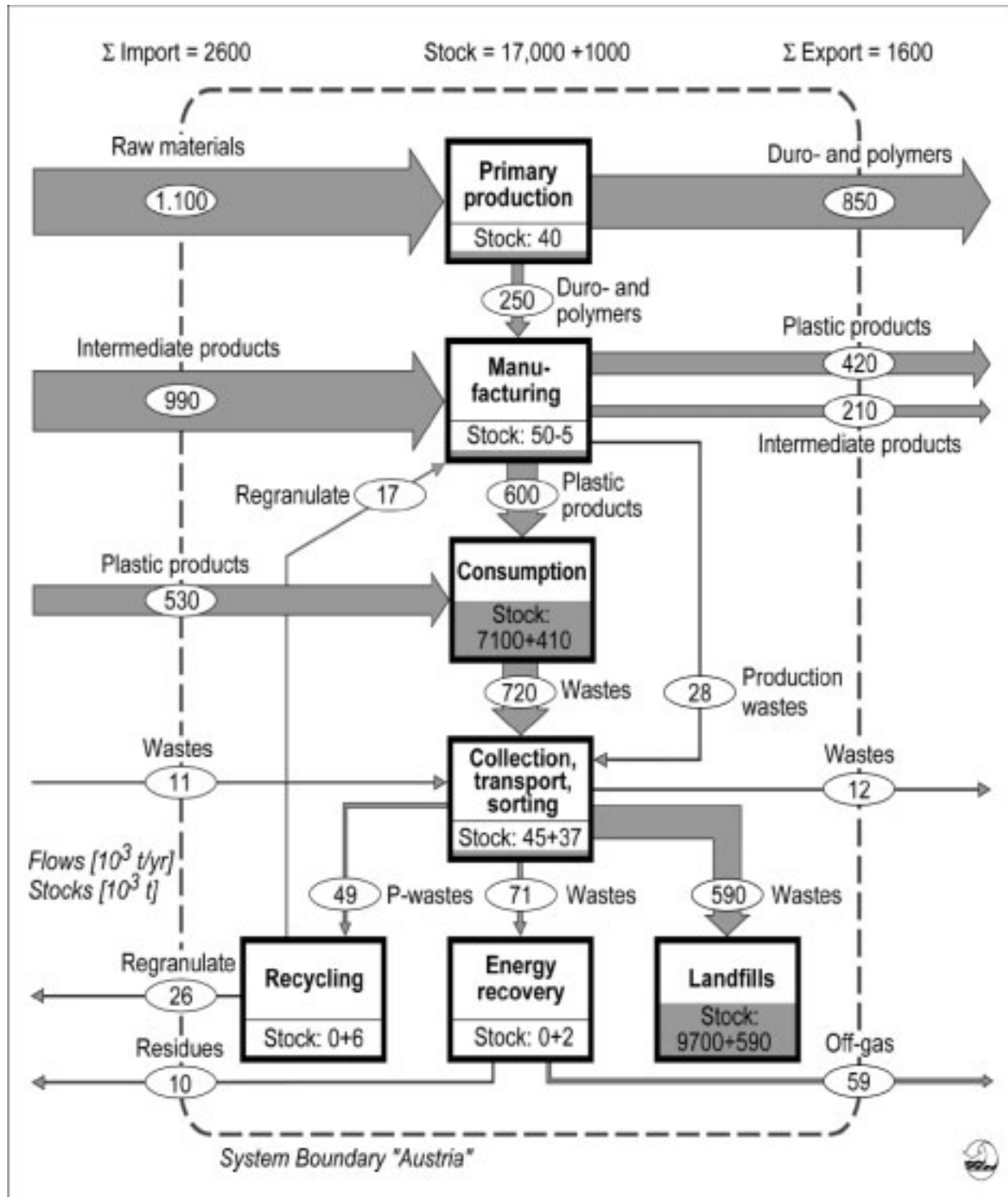

Figure 1 Plastic flows and stocks in Austria in 1994 (FEHRINGER & BRUNNER, 1997)

Besides the fact that almost all flows increased during this 10 years period, major changes can only be seen in the field of waste management.



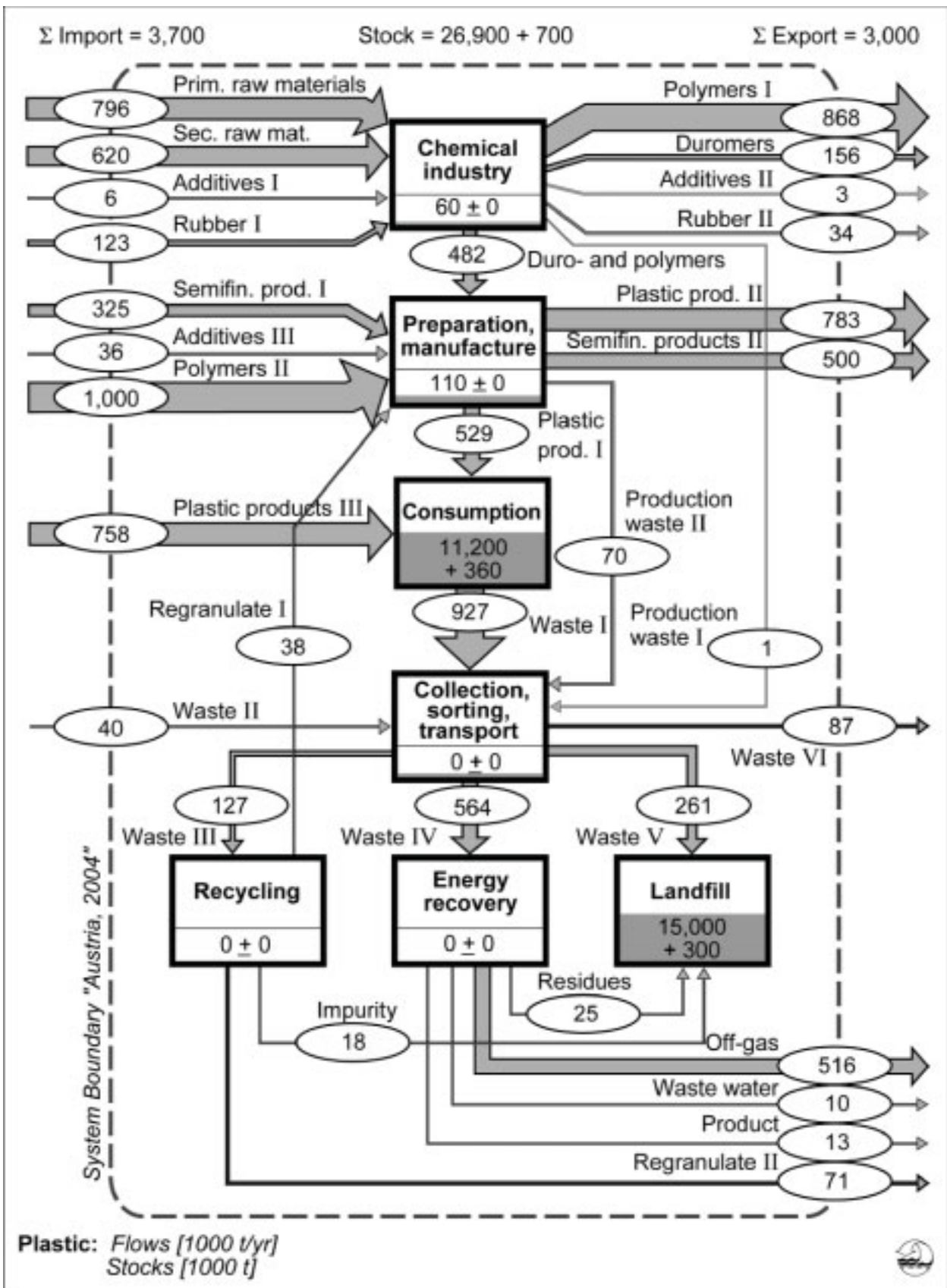

Figure 2 Plastic flows and stocks in Austria in 2004 [BOGUCA & BRUNNER, 2007]

In 1994, one year after the introduction of the Austrian packaging ordinance only a few tonnes of total plastic waste generated were recycled. Most of plastic waste was land-filled without any use of material or calorific value embedded.

In 2004 the figure changed energy recovery and recycling increased. Main driver for this development was not the packaging ordinance but the landfill directive which was introduced in 2004 with a special approval for an extension till 2008 for some federal states.

Table 1 compares the plastic flows in Austria and Poland for investigated years. It can be seen that the situation on Poland in 2004 is similar to the situation in Austria ten years ago. Most of plastic waste generated is landfilled. The advantage of Poland as a member state of the European Union is the implementation of the European waste framework directive. This saves time and resources which will no longer be landfilled.

*Table 1 Comparison of plastic flows per capita in Austria and Poland (BOGUCA & BRUNNER, 2007)*

	<b>Austria</b>		<b>Poland</b>
	<b>[kg/cap]</b>		<b>[kg/cap]</b>
	<b>1994</b>	<b>2004</b>	<b>2004</b>
Total plastic import plus domestic production	329	463	146
Total plastic export	188	302	48
Plastic consumption	141	161	98
Plastics to stock "in use"	51	45	46
Total plastics in stock "in use"	888	1.400	605
Plastic waste flow (incl. import-export of waste)	94	119	54
Plastic waste flow to Recycling	6	16	3
Plastic waste flow to Energy Recovery	9	71	2
Plastic waste flow to Landfilling	74	33	49
Total plastic stock in landfills	1.213	1.938	789

### 3 Plastic waste management in Austria

#### 3.1 Plastic waste generation in Austria

Figures on plastic flows and stocks in Austria and Poland given in 2 include plastic polymers, elastomeres and materials based on polymeres. All following figures do not include elastomeres, fibres, varnish, non-plastics in plastic composites, dirt and moisture. With this definition plastic waste generation rate in Austria is about 600.000 t in 2007 (FEHRINGER ET AL, 2010).

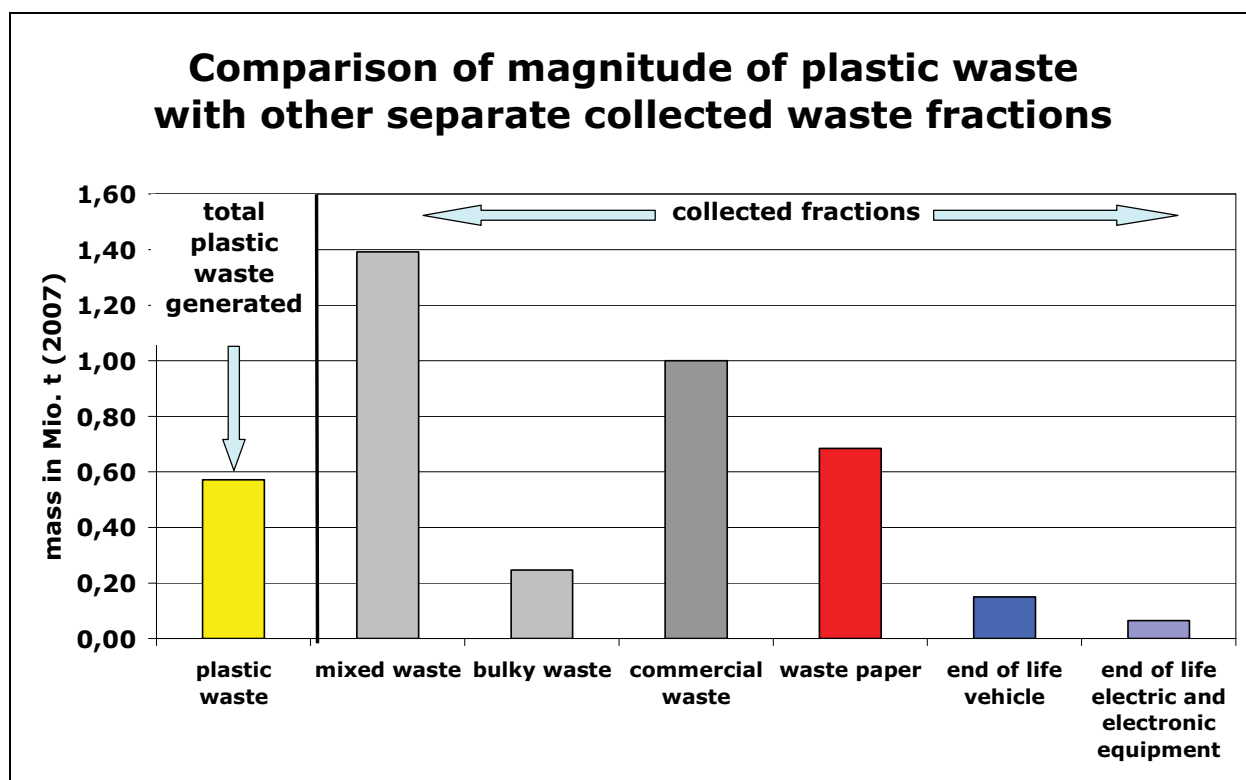

Figure 3 Comparison of magnitude of plastic waste (all collection schemes) with other separately collected waste fractions (FEHRINGER ET AL, 2010)

#### 3.2 Collection and recovery of plastic waste in Austria

Figure 4 gives an overview of collection schemes. 38 % of plastic waste generated is collected separately. This is compared to other countries a considerable share. But not all separately collected fractions consist of plastics only. Most of them consist of composites (end of life electric and electronic equipment) with a certain share of plastics. Mode of recycling depends on pre-treatment and therefore separately collected does not imply material recycling.

A better view of recycling and recovery of plastic waste is given in Figure 5. 44 % of total plastic waste is plastic packaging waste and 24 % goes into material recycling.

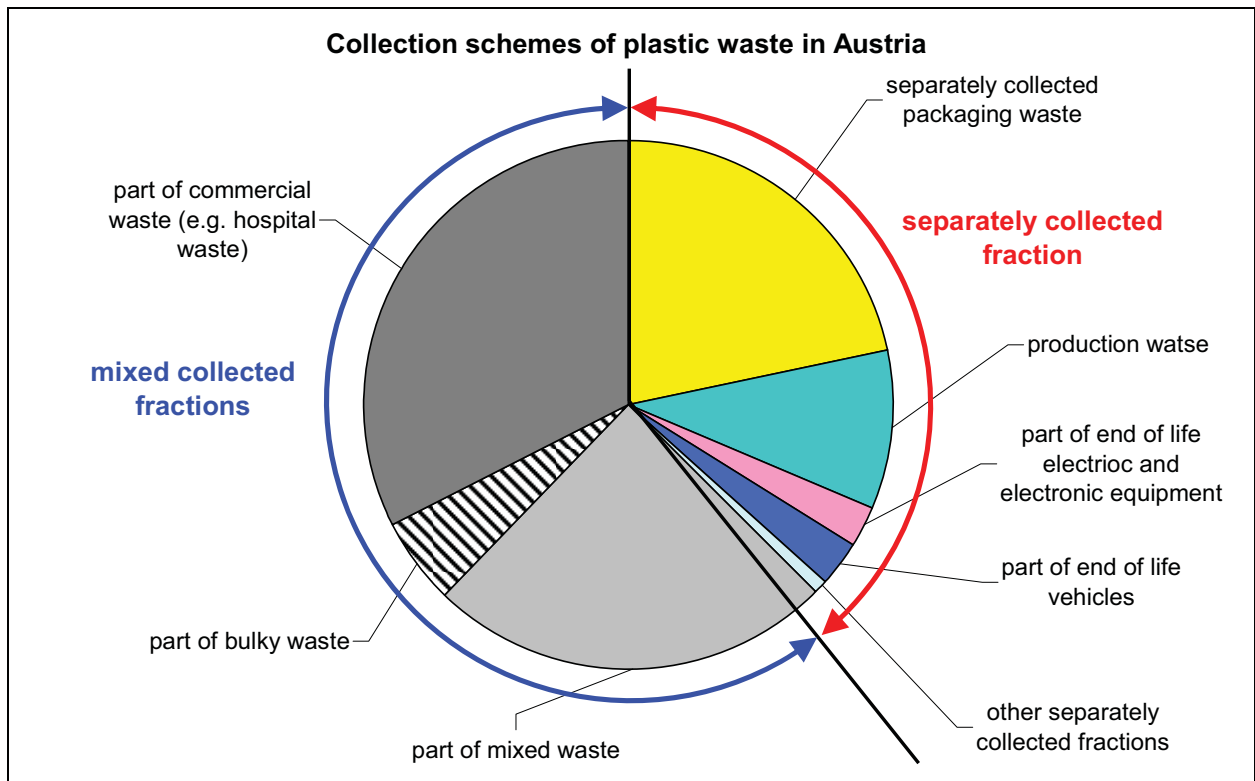

Figure 4 Collection schemes of plastic waste in Austria (FEHRINGER ET AL, 2010)

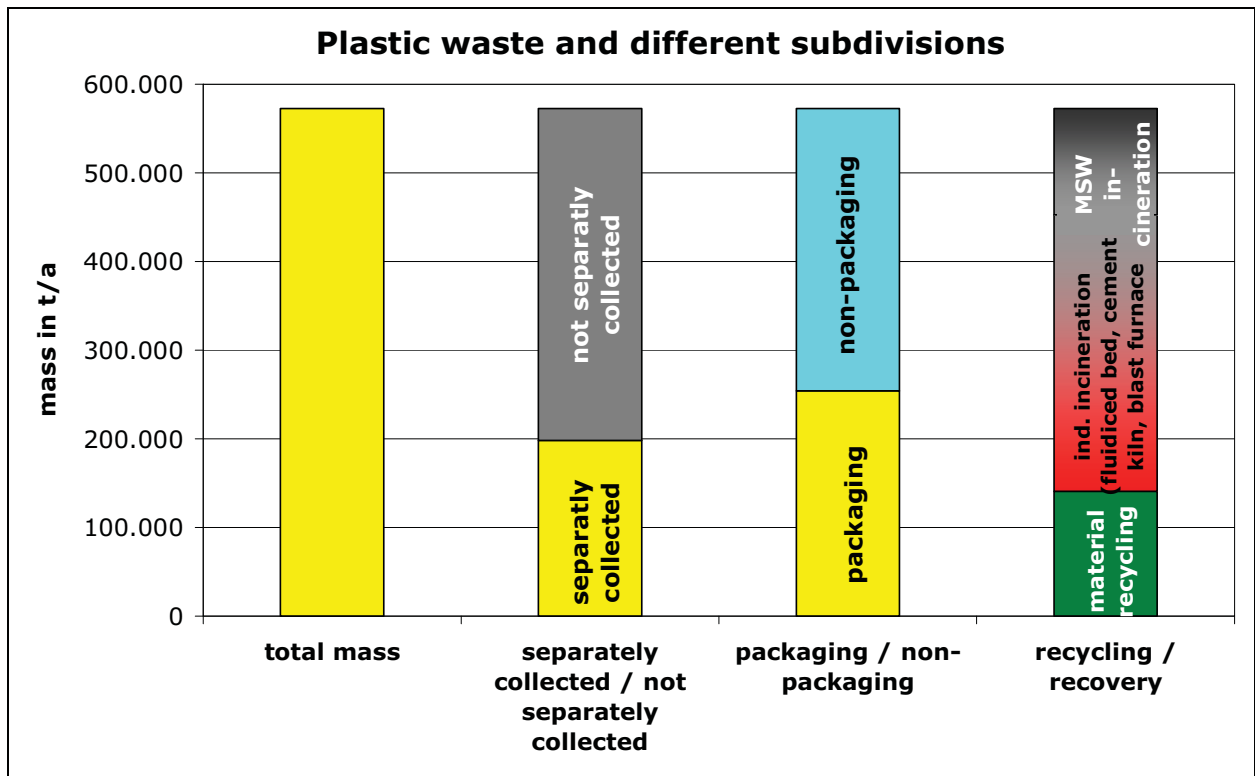

Figure 5 Total plastic waste generated, collection scheme, share of packaging and recovery options (FEHRINGER ET AL, 2010)

Due to large benefits (saved primary production) material recycling has the highest net benefit expressed in crude oil equivalent. Feedstock recycling and industrial co-

incineration in cement kiln or fluidized bed incineration plants have also a higher net benefit compared to municipal solid waste incineration. Nevertheless the share of suitable plastic waste decreased the other way round (PILZ, 2007). In total up to 600.000 t crude oil equivalent could be saved year by year with an optimized allocation of plastic waste to recycling and recovery technologies.

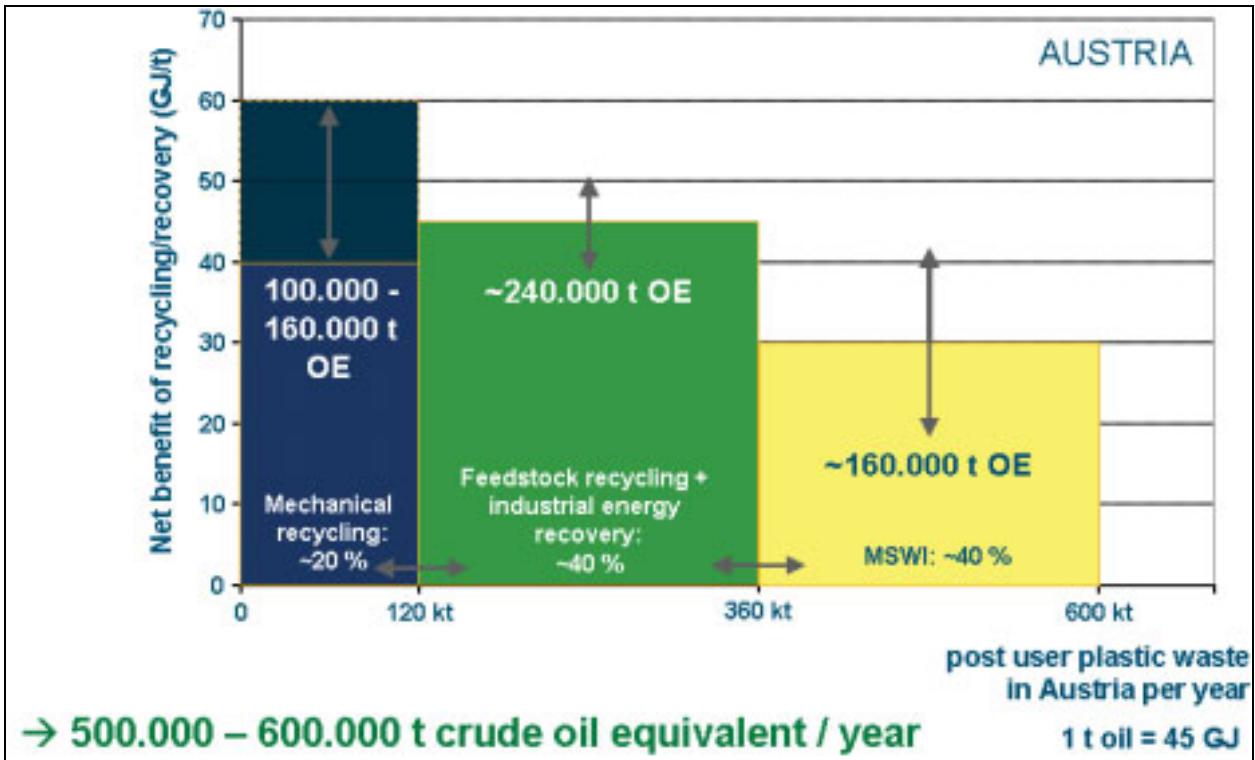

Figure 6 Potential of different recycling and recovery options and net benefit expressed in saved crude oil equivalent (PILZ, 2007)

## 4 Bioplastics

A study founded by the Austrian Klima- und Energiefond investigates the potential of bioplastics to protect the climate. A main finding is that today's bioplastics do not have significantly higher potential to save greenhousegas emissions than conventional plastics as the production of bioplastic polymeres is still energy intensive and production of products is similar.

Figure 7 shows the greenhousegas emissions of conventional and bioplastics in total life cycle. The difference is rather small, but as bioplastic is a very young material improvements in the future could increase the gap.

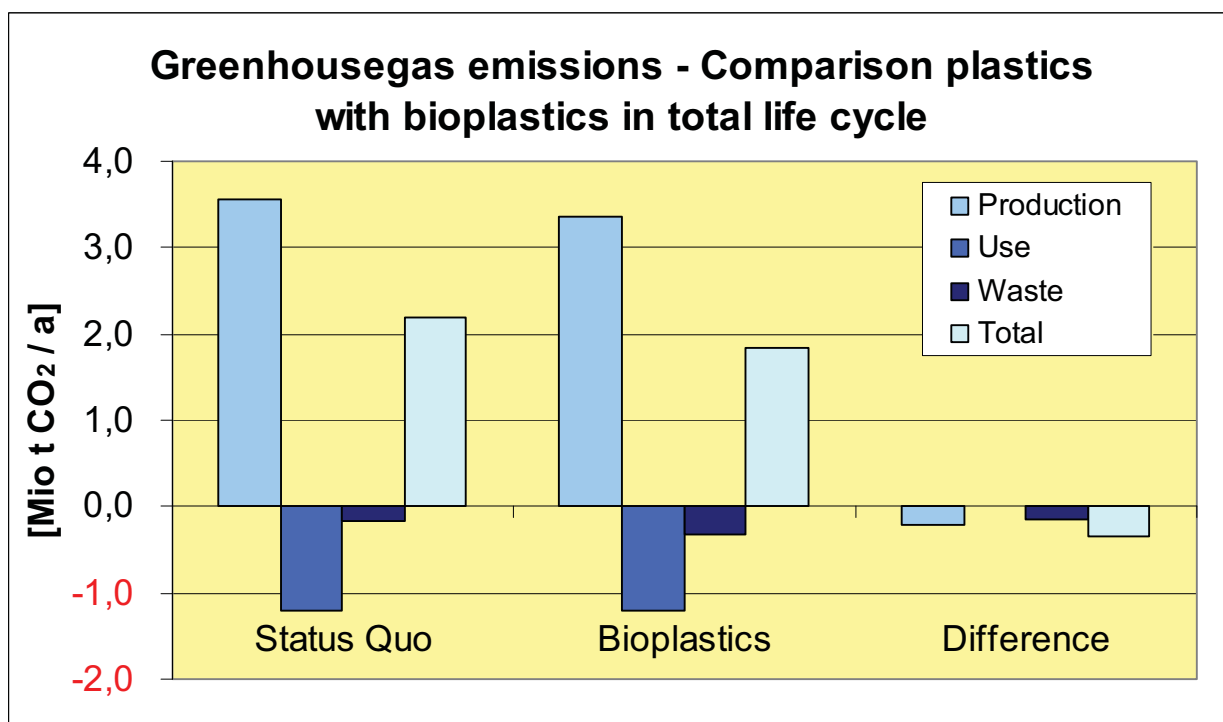

Figure 7 Comparison of greenhousegas emissions of conventional plastics and bioplastics (BRANDT ET AL., 2010)

## 5 Strengths and opportunities of Austrian plastic waste management

Relevant stakeholders see the strengths of Austrian plastic waste management in: (FERINGER ET AL., 2010)

- No landfilling of plastic waste in 2010
- Strong legislation (packaging ordinance and landfill directive)
- Reasonable share of separate collection (not too much)
- Large share of material recycled plastic waste
- Numerous plants for pre-treatment, feedstock recycling and energy recovery
- Innovative companies producing recycling technologies (PET recycling, bottle-to-bottle recycling)

During the same stakeholder dialogue the most supported opportunity was:

- Plastic waste management should be based on comprehensive assessment including ecologic and economic aspects for decisions. Indicators for a sustainability assessment of waste management options should be developed.

## 6 Literature

- Brandt, B., Pilz, H., Fehring, R., Windsperger, A. & Thurner, M. 2010 Klimaschutzpotenziale beim forcierten Einsatz biogener und konventioneller Kunststoffe - KliKu, Klima- und Energiefond (Hrsg.), Vienna, Austria (not published yet)
- Bogucka, R. & Brunner, P. H. 2007 Evaluation of plastic flows and their management in Austria and Poland: Challenges and opportunities, Vienna University of Technology, Institute for Water Quality, Resource and Waste Management, Vienna, Austria
- Fehring, R. & Brunner, P. H. 1997 Kunststoffflüsse und Möglichkeiten der Kunststoffverwertung in Österreich. Monographien Band 80, Umweltbundesamt Wien (Hrsg.), Vienna, Austria
- Fehring, R., Hutterer, H. & Pilz, H. 2010 Entwicklung einer nationalen Strategie mit dem Ziel maximaler Ressourcenschonung durch Kunststoffverwertung in Österreich – SEKU 2010+, Bundesministerium für Wirtschaft, Jugend und Familie (Hrsg.) & PlasticsEurope, Vienna, Austria (not published yet)
- Pilz, H. 2007 Zahlen und Fakten zur Energieeffizienz von Kunststoffprodukten, Präsentation beim 3. Österreichischen Kunststofftag, Vienna, Austria

### Author's address

Roland Fehring  
denkstatt GmbH  
Hietzinger Hauptstraße 28  
A-1130 Wien  
Telefon +43 1 5886 89 00 22  
Email: [roland.fehring@denkstatt.at](mailto:roland.fehring@denkstatt.at)  
Website: [www.denkstatt.at](http://www.denkstatt.at)



# **Bewertung der Systemkosten für den Einsatz von Kunststoffen unter Einbeziehung der Kosten für Entsorgung bzw. Verwertung**

**Reinhard Schu, Jens Niestroj, Kirsten Schu**

EcoEnergy Gesellschaft für Energie- und Umwelttechnik mbH, Walkenried

## **Evaluation of system costs for the use of plastics with regard to disposal costs**

### **Abstract**

In this paper we evaluate the real costs for the use of plastics regarding costs for disposal. These costs are until now not sufficiently reflected in the consumer prices. This causes massive competitive disadvantages for renewable raw materials, even though these are produced with significantly lower energy consumption and disposal costs. Plastics waste has no recycling potential and should be regarded as waste for disposal.

### **Inhaltsangabe**

Der Beitrag bewertet die realen Systemkosten der Kunststoffproduktion und Entsorgung. Die Entsorgungskosten für Kunststoffe fließen bislang jedoch nur teilweise in die Konsumentenpreise ein, so dass ein erheblicher Wettbewerbsnachteil für nachwachsende Rohstoffe entsteht, obwohl diese erheblich geringere Produktionsenergie verbrauchen und geringere Entsorgungskosten verursachen. Kunststoffabfall ist kein Wertstoff und sollte als Abfall zur Beseitigung betrachtet werden.

### **Keywords**

Kunststoffe, Verwertung, Entsorgung, Systemkosten, Antimon, Plastics, Recycling, Disposal, System costs, Antimony

## **1 Einleitung**

Kunststoffe sind zunehmend Teil unserer Alltagswelt. Jeder, der sich in irgendeiner Form mit Abfall beschäftigt, begegnet ihnen allerdings noch ein zweites Mal - am Ende ihrer Nutzungsdauer als Bestandteil des Abfalls. Anlass für den vorliegenden Beitrag waren mehrere Beobachtungen über Kunststoffe, die wir im Rahmen unserer Tätigkeit machen konnten.

Die Firma EcoEnergy betreibt seit 2005 die Demonstrationsanlage für das SCHUBIO<sup>®</sup>-Verfahren zur nassmechanischen Trennung von Abfällen. Im Verfahren werden biogene, nativ organische Bestandteile von den organischen Bestandteilen aus fossilem Kohlenstoff, den Kunststoffen, getrennt. Die Analysenergebnisse dieser Fraktionen zeigen in allen Versuchen eine Schadstoffabreicherung in den nativ organischen Fraktionen gegenüber einer Schadstoffanreicherung in den kunststoffhaltigen Fraktionen.

Ein zweiter Hinweis aus der Praxis für eine Schadstoffbelastung von Kunststoffen zeigte sich bei einer Analyse der für eine Mitverbrennung bis 25 % der Feuerungswärmeleistung in einem Kohlekraftwerk vorgesehenen Ersatzbrennstoffe. Bei der Aufstellung der Kriterien für die Mitverbrennung wurden neben den Emissionen auch die Qualitäten von REA-Gips und Flugasche berücksichtigt. Im Ergebnis konnten nur Stoffgemische, die kaum Kunststoffe enthielten, die Kriterien einhalten.

Diese Ergebnisse gaben den Anstoß für eine genauere Betrachtung der Systemkosten für den Einsatz von Kunststoffen unter Berücksichtigung der Kosten für die Entsorgung.

## 2 Herstellung von Kunststoff

Rohstoff für die Kunststoffproduktion ist Rohbenzin (Naphtha). Naphtha entsteht als Nebenprodukt bei der Rohöldestillation.

Noch bis in die 50er Jahre wurde das Rohbenzin direkt als Kraftstoff verwendet. Mit der erhöhten Kompression der Verbrennungsmotoren wurde die Entwicklung klopfesterer Kraftstoffe mit höherer Oktanzahl notwendig. Naphtha wurde so zu einem Nebenprodukt der Kraftstoffherstellung.



Abbildung 1: Destillation von Rohöl und Produktion von Kunststoff

In modernen Raffinerien fällt etwa 9 % Naphtha bei der Erdölraffination an. Wird jedoch mehr Benzin und Diesel und weniger Schweröl produziert, entstehen ca. 12 % Naphtha. In Deutschland werden ca. 120 Mio. t Rohöl verbraucht und 20 Mio. t Kunststoffe produziert. Zusätzlich benötigtes Naphtha wird aus Rotterdam über eine Produktpipeline

nach Deutschland importiert. Aus dem Naphtha werden über einen Steamcracker die Zielprodukte zur Kunststoffherstellung, vor allem Ethen, gewonnen (siehe Abbildung 2).

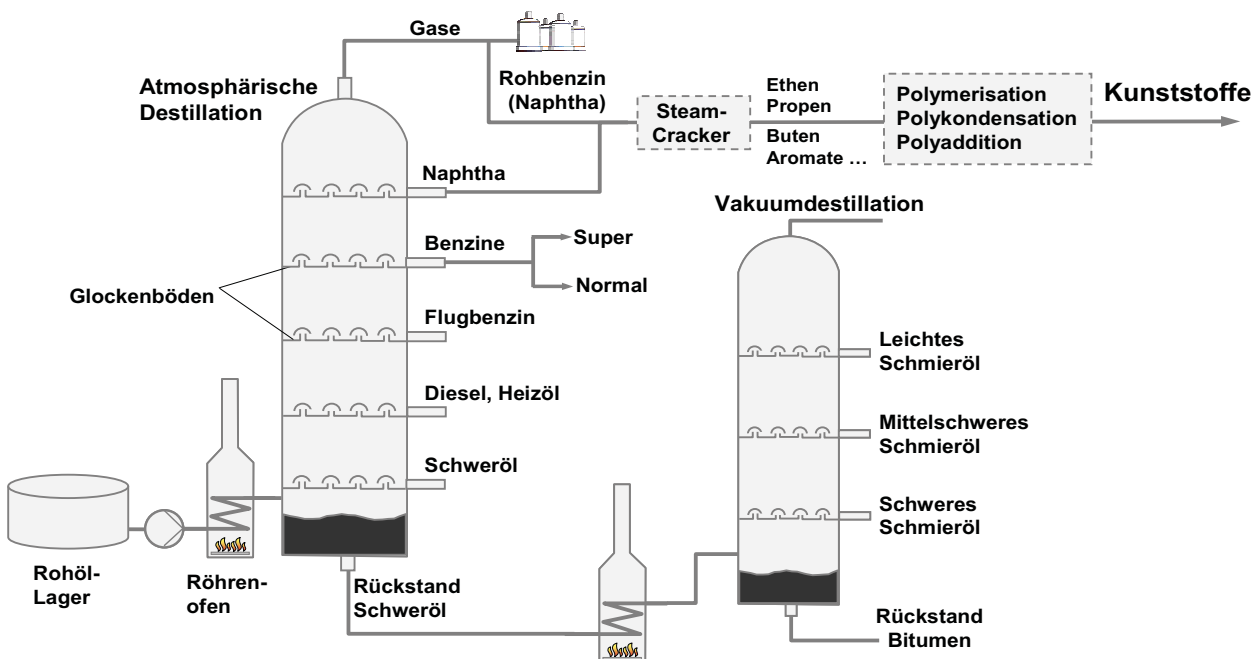

Abbildung 2: Produkte eines Naphtha-Streamcrackers

Die Verteilung der einzelnen Fraktionen ist abhängig von den Eigenschaften des Rohöls. Die Ausgangsstoffe für die Kunststoffproduktion werden also nicht in Abhängigkeit vom Kunststoffbedarf (Consumer-Markt), sondern in Abhängigkeit von der Rohölqualität und den technischen Möglichkeiten der Raffination erzeugt.

Der Betrieb der Raffinerie ist dementsprechend nur möglich, wenn auch das entstehende Naphtha zu Kunststoffen weiterverarbeitet wird. Während der Finanzkrise 2008/2009 wurde dieser Zusammenhang besonders deutlich. Im März 2009 wurde aufgrund mangelnder Nachfrage nach Kunststoffen der Steamcracker der BASF in Ludwigshafen abgestellt. In den USA waren zwar die Lager für Rohöl gefüllt, für Benzin gingen die gelagerten Mengen jedoch zurück, da die Abnahme der Kunststoffe eingebrochen war. Die Nachfrage nach Kunststoffen ging je nach Sorte zwischen 20 % und 70 % zurück.

Entscheidend für den Betrieb einer Raffinerie ist die Logistik der entstehenden Nebenprodukte, die wie z. B. Naphtha in erheblichem Umfang anfallen. Für das Produkt Benzol zum Beispiel können schon aufgrund der Bestimmungen der Störfallverordnung nicht kurzfristig Lagerkapazitäten geschaffen werden. Mangelnde Nachfrage führt dann zum Abschalten der Raffinerie. Die Produktion von Polystyrol, dessen Rohstoff Benzol ist, kann daher nicht unterbrochen werden. Um die Abnahme zu sichern, werden die

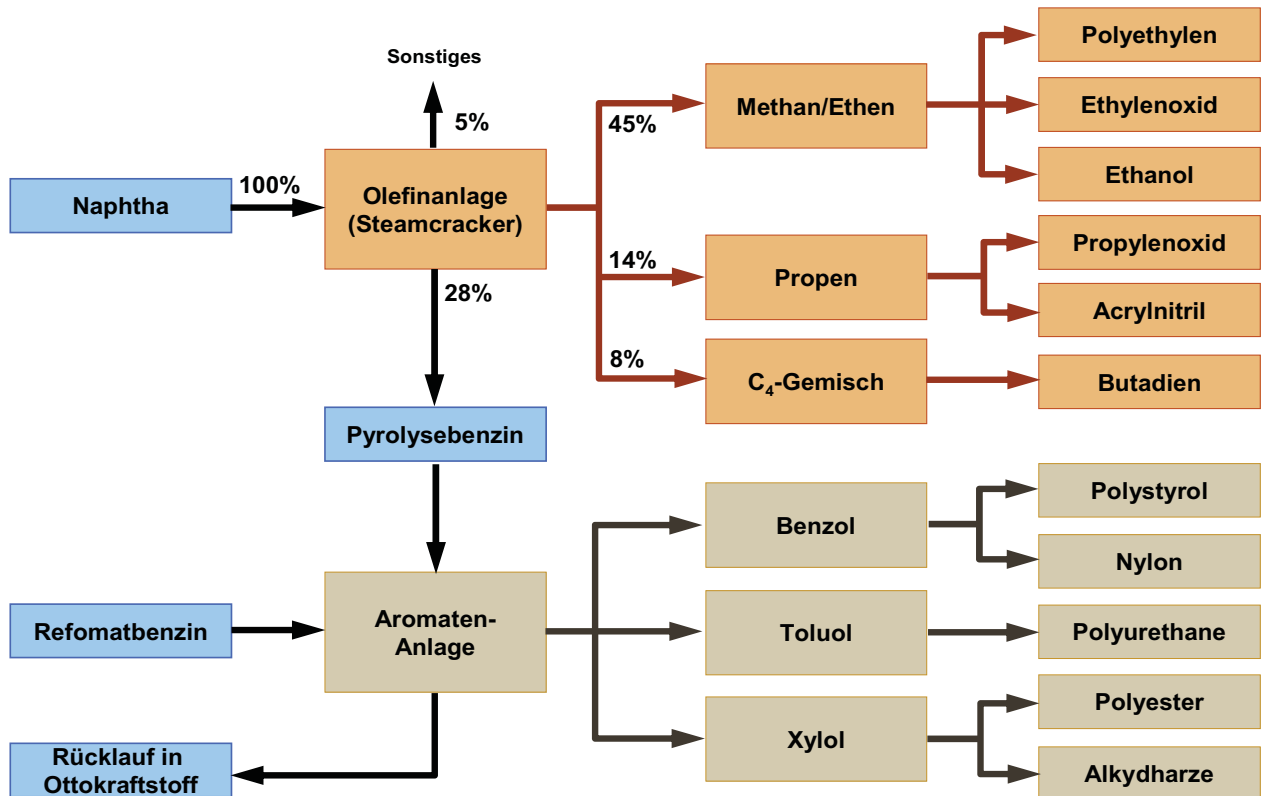
Preise für Kunststoffe so angepasst, dass sie billiger sind als die entsprechenden natürlichen Rohstoffe.

Ein weiteres Beispiel ist das in der Abfallwirtschaft viel diskutierte PVC. PVC besteht zu 57 % aus Chlor, zur Produktion wird HCl eingesetzt. In der chemischen Industrie bestand früher aus der Kochsalzelektrolyse ein Überschuss an Chlorgas, da NaOH in der Produktion gebraucht wurde. Mit der Produktion von PVC wurden sowohl Chlorgas als auch Naphtha beseitigt, sie bot daher einen Ausweg aus einem Entsorgungsproblem. Aufgrund der angekurbelten Nachfrage und Akzeptanz für PVC hat sich heute diese Situation umgekehrt.

### 3 Kosten der Rohkunststoffproduktion

In vielen Raffinerien wird Naphtha immer noch abgefackelt. Zur Kunststoffproduktion wird Naphtha über einen Steamcracker in diverse kurzkettige Kohlenwasserstoffe aufgespalten.

Wegen seiner heterogenen Zusammensetzung ist Naphtha nicht einfach zu verbrennen. Gasturbinen zur energetischen Verwertung von Naphtha müssen über externe Brennkammern verfügen sowie speziell explosionsgeschützt ausgeführt sein. Zudem haben sie geringe Standzeiten und müssen nach 3 bis 5 Jahren erneuert werden. Wegen der leichten Entzündlichkeit stellt der Transport auch zudem eine logistische Herausforderung dar, daher sind Kunststoffproduktion und Raffinerien häufig in räumlicher Nähe installiert.

*Tabelle 1: Aktuelle Brennstoffkosten im Vergleich zu Naphtha*

<b>Brennstoff</b>	<b>Bezugskosten übliche Einheit</b>	<b>Energieinhalt</b>	<b>energiebezogene Bezugskosten</b>
Naphtha	332,00 €/t	43,50 MJ/kg	27,48 €/MWh
Rohöl	49,60 US\$/bbl	42,80 MJ/kg	22,26 €/MWh
Heizöl S Kraftwerke	167,00 €/t SKE	41,80 MJ/kg	20,50 €/MWh
Heizöl L Industrie	303,00 €/t SKE	41,80 MJ/kg	37,20 €/MWh
Erdgas Industrie	22,33 €/MWh	-	22,33 €/MWh
Erdgas Kraftwerke	21,84 €/MWh	-	21,84 €/MWh
Steinkohle	112,50 €/t	29,32 MJ/kg	13,81 €/MWh
Braunkohlenstaub	112,00 €/t SKE	21,00 MJ/kg	13,75 €/MWh
Altholz	-1,00 €/t	15,00 MJ/kg	-0,24 €/MWh
Holz, trocken, gehäckselt	30,00 €/fm	15,00 MJ/kg	11,08 €/MWh
Stroh, trocken	60,00 €/t	17,00 MJ/kg	14,95 €/MWh
Getreideganzpflanze	90,00 €/t	17,00 MJ/kg	22,42 €/MWh
Getreide	120,00 €/t	17,00 MJ/kg	29,90 €/MWh

Pflanzenöl	500 €/m <sup>3</sup>	37,00 MJ/kg	52,88 €/MWh
Biogas aus Maissilage (Bezug: Biogasausbeute)	22,00 €/t	-	23,20 €/MWh

Eine Verarbeitung von Naphtha zu Kunststoffen ist gegenüber der energetischen Nutzung daher lukrativer. Die Preise für Naphtha lagen in den letzten Jahren zwischen 150 €/t und 400 €/t. Die Tabelle 2 zeigt zum Vergleich die Kosten verschiedener Brennstoffe.

Der Brennstoff Naphtha rangiert im Vergleich zu Benzin, Diesel und Heizöl L auf einem niedrigeren Preisniveau. Die Verarbeitung von Naphtha zu den Grundstoffen für die Kunststoffproduktion erfordert nochmals ca. die gleiche Energie wie der Energiegehalt des Naphthas selbst.

*Tabelle 2: Produktionsenergie als kumulierter Energieaufwand (KEA) im Vergleich zu Beschaffungs- und Entsorgungskosten von Kunststoffen und anderen Materialien*

Material	KEA MJ/kg	Beschaffungskosten		Heizwert MJ/kg
		€/t	€/MWh KEA	
Naphtha (Rohbenzin)	55	332	21,7	43,5
LDPE Folie	91,8	800	31,4	46
HDPE Folie	99,8	800	28,9	46
PP Spritzguss	118,8	850	25,7	44
PVC Folie	66,3	820	44,6	20
PS (high impact)	91,8	860	33,7	46
PET Flasche	101,4	1060	37,6	46
PET Folie	109,2	1020	33,6	46
Stahl	35,8	247	24,8	0
Aluminium	193,3	1450	27,0	0
Weißglas	12,7	140	39,6	0
Wellpappe, Karton	19,8	160	29,1	15
Papier (grafische etc.)	44,8	500	40,2	17
Holzspäne f. Pressplatten	17,0	55	11,6	16
Stammholz, frisch	14,0	150	38,6	10
Stammholz, getrocknet	19,0	220	41,7	15

In Deutschland werden jährlich ca. 20 Mio. t Kunststoffe produziert. Würden diese 20 Mio. t nicht produziert, ergäbe sich bei einer durchschnittlichen Produktionsenergie von 90 MJ/kg Kunststoff eine Gesamtbrennstoffleistung von ca. 62 Gigawatt. Übersetzt in elektrische Grundleistung bei 50 % el. Wirkungsgrad, entspräche dies einem Grundlastkraftwerk mit 30 Gigawatt elektrischer Leistung. Die installierte Leistung aller Kern-

kraftwerke in Deutschland beträgt heute 21,5 Gigawatt. Die gesamte durchschnittliche Jahresleistung in Deutschland beträgt 80 Gigawatt. Würden diese Kunststoffe in MVA verbrannt, ergäbe dies nur eine Feuerungswärmeleistung mit der Grundlast 29,5 GW und einer elektrischen Leistung bei 24 % el. Wirkungsgrad von 7 GW. Die energetische Verwertung von Kunststoffen kann nur ein Viertel der zur Kunststoffherstellung eingesetzten Energie (KEA) als Stromäquivalent zurückgewinnen.

## **4 Verdrängung von nachwachsenden Rohstoffen durch Kunststoff**

Bei der Raffination von Rohöl fallen die Fraktionen Naphtha, Benzin, Diesel/Heizöl, Schweröl, Bitumen und Petrolkoks in einem gewissen Verhältnis an, zu dem auch der Absatz der Produkte erfolgen muss. Das folgende Beispiel zeigt, wie hier auch die Politik massiv eingreift, um den Absatz zu gewährleisten. Unter anderem wegen der hohen Mineralölsteuern gibt es in Deutschland seit längerer Zeit den Trend von der Ölheizung hin zur Gasheizung, sowohl in Privathaushalten als auch in der Industrie. Dies führte zu einem Überangebot von Diesel auf dem Markt. Über eine entsprechende Steuerpolitik wurde der Diesel verbilligt. Heute ist Deutschland eines der Länder mit dem höchsten anteiligen Dieselaabsatz.

Seit den 50er Jahren des vorigen Jahrhunderts werden auf Kunststoffe keine Mineralölsteuern oder andere Abgaben erhoben. Auch Kunststoffe, die zur energetischen Verwertung in Kohle- oder Zementwerken, zur Reduktion in Stahlwerken oder zur Methanolproduktion in der Schwarzen Pumpe eingesetzt werden oder wurden, unterliegen nicht der Mineralölsteuer. Auf alle anderen Mineralölprodukte, die zur Produktion von Energie verwendet werden, wird Mineralölsteuer erhoben.

Der stoffliche Einsatz nachwachsender Rohstoffe, wie zum Beispiel Baumwolle, wird in keiner Weise gefördert. Es bilden sich daher bereits Initiativen von Textilanbietern wie IKEA, Otto, C&A und H&M, um Baumwollbauern in Afrika zu unterstützen, da deren Existenz durch die Konkurrenz billiger synthetischer Textilien, die unter anderem aus PET-Recyclingmaterial hergestellt werden, massiv bedroht ist.

Auch das EEG, das die energetische Nutzung von Frischholz als nachwachsenden Rohstoff zur energetischen Nutzung fördert, trägt dadurch zu steigenden Holzpreisen bei. Eine Förderung von stofflich genutztem Holz erfolgte nicht, so dass auch hier die Kunststoffindustrie gute Möglichkeiten hat, den Werkstoff Holz in vielen Applikationen zu ersetzen. So gibt es zum Beispiel Produkte aus dickwandigem Kunststoff wie Gartenpalisaden, Gartenbänke oder Terrassenbohlen, die Holz ersetzen.

Viele natürliche Faserdämmstoffe verbrauchen bei gleicher Dämmleistung nur ca. ein Zehntel der Produktionsenergie von kunststoffbasierten Dämmstoffen. Dennoch können sich diese Dämmstoffe preislich nicht gegenüber Dämm-Materialien aus PUR und Polystyrol durchsetzen. Dämmung wird heute unabhängig von der Produktionsenergie des eingesetzten Dämmstoffs staatlich gefördert.

Aufgrund der hohen Produktionsenergie, gekoppelt mit hohen Entsorgungskosten, ist die Dämmung mit Kunststoffen unter ökologischen und volkswirtschaftlichen Gesichtspunkten kritisch zu betrachten. Hier ist die Politik zum Handeln aufgefordert.

## **5 Entsorgung von Kunststoffabfällen**

Der Kunststoffanteil in den Abfällen wird heute meist als Wertstoff angesehen. Dennoch werden heute ca. 50 % der Kunststoffe thermisch beseitigt. Selbst die Verwertung von gemischten Gewerbeabfällen ist zweifelhaft. Die separate Sammlung von Kunststoffen aus Haushaltungen zur Verwertung steht weiter in der allgemeinen Kritik.

### **5.1 Energetische Verwertung von Kunststoffabfällen**

Reine Produktionsabfälle aus Polyethylen und Polypropylen mit geringen Schadstoffgehalten können bei entsprechender Qualitätskontrolle in Kohlekraftwerken und Zementwerken energetisch verwertet werden. Kritische Inhaltstoffe von Kunststoffen allgemein sind Chlor, Brom und vor allem die Schwermetalle Quecksilber, Blei, Cadmium und Antimon. Neben dem Emissionsschutz sind auch die erhöhten Belastungen der Produkte Zement oder der zu verwertenden Reststoffe aus dem Kohlekraftwerk zu beachten.

#### **5.1.1 Cadmiumbelastung**

Cadmium ist ein bei der Zinkverhüttung anfallendes Abfallprodukt und wurde früher als Farbpigment in Kunststoffen allgemein und vor allem als Stabilisator in PVC eingesetzt. Nach unserer Betrachtung der Schadstoffverteilung eines Steinkohlekraftwerkes bei einer Mitverbrennungsrate von Abfällen von 25 % der Feuerungswärmeleistung müssen Cadmiumkonzentrationen von < 0,4 mg/kg eingehalten werden, um die Grenzwerte der REA-Gips Verwertung einhalten zu können. Biogene Abfälle ohne Kunststoffe können diese Grenzwerte einhalten. Der Grenzwert der Bundesgütegemeinschaft Sekundär-brennstoffe e.V. für Cadmium von 4 mg/kg ist auf geringere Mitverbrennungsraten berechnet. Kunststoffhaltige Abfälle können die neuen schärferen Grenzwerte kaum einhalten.



Nach der EU-Richtlinie 76/769/EWG gilt für Kunststoffe ein Grenzwert für Cadmium von 100 mg/kg. Über die Hälfte des Kunststoffbedarfs in Deutschland wird importiert, obwohl wir, bezogen auf die Import-Exportbilanz, insgesamt ein Kunststoffexporteur sind. Eine Überwachung der Cadmiumbelastung der importierten Kunststoffe ist fast unmöglich. Die Cadmiumkonzentration kann bei einigen Kunststoffen bei über 200 mg/kg liegen.

### **5.1.2 Antimonbelastung**

Antimon ist als Korrosionskatalysator bei der energetischen Verwertung bisher unbekannt und wurde bisher auch nicht untersucht. Die Antimonkonzentrationen in Kunststoffen sind um den Faktor 1.000 bis 2.000 höher als in der Kohle. In Naturprodukten ist Antimon in einer Konzentration von < 0,01 mg/kg vorhanden, in PET sind 300 mg/kg und in Polyester 150 mg/kg produktionsbedingt enthalten. Antimonhaltige Flammenschutzmittel werden aufgrund gestiegenen Brandschutzes bei Kunststoffen im Elektroniksektor, Automobilbau und in der Bauindustrie allgemein eingesetzt. In der Rückwand eines Fernsehers wurden Antimongehalte von 4.400 mg/kg gemessen.

Seit 2006 ist die Migration von giftigem Antimon in das Getränk bei PET-Flaschen nachgewiesen worden. Auch warnen Ärzte vor der Verwendung von PET-Textilien, die u. a. aus PET-Recyclat produziert werden, da durch den Schweiß Antimon in die Haut übergehen kann und zu Hautreizungen und Neurodermitis führen kann. In Japan wurde versucht, Antimon bei der PET-Herstellung durch teures Titan und Phosphat zu ersetzen. Aufgrund der Gelbfärbung bei diesem Prozess wurde wieder auf Antimonverbindungen zurückgegriffen. Zurzeit gibt es dafür keinen Lösungsansatz.

Der Antimongrenzwert für die energetische Verwertung von Abfällen in der Zementindustrie beträgt in der Schweiz 5 mg/kg. Die Grenzwerte für „Kunststoffabfälle“ zur energetischen Verwertung in der Zementindustrie wurden auf 300 mg/kg und speziell für PET-Abfälle auf 800 mg/kg heraufgesetzt. In Deutschland wurde aufgrund der erhöhten Antimonkonzentration in den Kunststoffabfällen der Antimongrenzwert auf 50 mg/kg von der Bundesgütegemeinschaft Sekundärbrennstoffe e.V., Deutschland, für Abfälle heraufgesetzt. Eine Langzeitbetrachtung bzgl. der Herauslösung von Antimon im Altbeton bei der Verwendung von antimonbelastetem Zement ist bisher nicht erfolgt. Verbindliche Erklärungen bzgl. einer Einschränkung des Antimoneinsatzes in Kunststoffen stehen noch aus. Ein Ersatz für die Funktion von Antimon sowohl als Stabilisator bei PET und Polyester oder Synergist bei bromierten Kunststoffen ist technisch noch nicht gefunden.

### 5.1.3 Bleibelastung

Blei wird als Stabilisator bei der PVC-Produktion und als Farbstoff verwendet. PVC, das heute in den Abfall gelangt, enthält ca. 2.000 mg/kg Blei, der Grenzwert für die Mitverbrennung liegt bei 70 mg/kg. Laut einer Selbstverpflichtungserklärung der PVC-Hersteller (Vinyl 2010) soll ab 2015 der Bleieinsatz im PVC beschränkt werden.

### 5.1.4 Quecksilberbelastung

Für die PVC-Herstellung wird Salzsäure verwendet. Noch heute wird zwei Drittel der Salzsäure mit Chloralkali-Elektrolyse mit dem Amalgamverfahren hergestellt. Bei diesem Verfahren ist es unvermeidbar, dass die Salzsäure mit Quecksilber in Kontakt kommt und das Quecksilber in das PVC eingebunden wird. 1973 wurden 58 mg Quecksilber pro kg Chlor verbraucht. PVC-Produkte haben eine Nutzungsdauer von 2 bis 50 Jahren. Die Grenzwerte für die Mitverbrennung liegen bei 0,6 mg/kg.

### 5.1.5 Chlorbelastung

Die Chlorfracht im kunststoffbelasteten Abfall stammt mittlerweile zu 60 % bis 95 % aus Kunststoffen. Bekanntestes Beispiel ist Roh-PVC mit 57 % Chloranteil, in den Produkten sind nur zwischen 30 % und 80 % Roh-PVC, teilweise als Verbundwerkstoffe, so dass nur 12 % bis 30 % Chloranteil in den PVC-basierten Kunststoffen enthalten ist. Dies erschwert die Aufreinigung durch automatische Sortiersysteme sehr, zudem ist der Ausschuss weder als PVC verwertbar noch ist die Akzeptanz der MVA-Betreiber gegeben, diese PVC-Gemische mit > 10 % Chloranteilen zu verbrennen. Chlor wird neben PVC auch in vielen anderen Kunststoffen als Flammschutzmittel eingesetzt.

Die energetische Verwertung von kunststoffbelastetem Abfall in entsprechend ausgelegten Abfallverbrennungsanlagen (EBS-Kraftwerke) mit Kraft-Wärme-Kopplung ist für fast alle Kunststoffabfälle möglich. Grundsätzlich ist jedoch die thermische Behandlung in MVA eine Beseitigung. Die Abgrenzung der Verwertung und Beseitigung in MVA ist durch das KrW-/AbfG festgelegt. Chlor trägt im Zusammenspiel mit den Chloridbildnern Schwermetalle und Alkalien maßgeblich zur Hochtemperaturkorrosion im Kessel bei. Viele EBS-Kraftwerke wurden für einen maximalen Chlorgehalt von ca. 1 % genehmigt. Nicht alle Abgasreinigungstechniken der heute betriebenen MVA oder EBS-Kraftwerke erlauben einen Chlorgehalt > 2,5 %. Neben den durch Kesselkorrosion verursachten Kosten, wie z.B. erhöhter Wartungsaufwand, geringere Verfügbarkeit und Reisezeit der Entsorgungsanlage, werden durch Chlor auch ein erhöhter Betriebsmittelverbrauch zur Chloreinbindung und erhöhte Kosten für die Entsorgung der Reaktionsprodukte aus der Chlorabscheidung verursacht.

Insgesamt entstehen allein durch die Chlorfracht ca. 400 bis 700 €/t PVC Mehrkosten, die Grundkosten der Abfallverbrennung sind noch nicht eingerechnet. Diese Mehrkosten sind in Preisgleitformeln der Ersatzbrennstoffanlagenbetreiber für die Annahme von Ersatzbrennstoffen hinterlegt. Es ist ersichtlich, dass das Vorhandensein von PVC in einem Abfallgemenge zur energetischen Verwertung nicht den Rückschluss zulässt, dass PVC energetisch in diesen Anlagen verwertet werden kann.

## 5.2 Rohstoffliche Verwertung

Die rohstoffliche Verwertung spielt in Deutschland keine Rolle mehr, nachdem 1999 die Kohleölanlage in Bottrop geschlossen wurde, die Vergasungsanlage zur Methanolsynthese SVZ 2005 den Betrieb eingestellt hat und die Stahlwerke die Annahme von DSD-Kunststoffen 2005 aufgegeben haben. Bei der Stahlproduktion spielt der Antimongehalt ebenfalls eine wesentliche Rolle. Antimon hat die Tendenz zur Korngrenzensegregation und - in wesentlich stärkerem Maß - zur Oberflächensegregation in Stählen und Eisenbasislegierungen. Dies führt zur Versprödung des Stahls und erhöhter Korrosionsneigung. In kommerziellen Stählen sind ca. 10 mg/kg Antimon enthalten. Wegen der zunehmenden Verwendung von Schrott minderer Qualität aus z. B. Automobilrecycling, Elektronikschrott und Eisenschrott von MVA-Schlacken ist damit zu rechnen, dass der Antimongehalt von Stählen in der Zukunft weiter ansteigen wird. Mit einer Renaissance der Kunststoffverwertung in der Stahlindustrie ist nicht zu rechnen.

## 5.3 Werkstoffliche Verwertung

Die werkstoffliche Verwertung von kunststoffhaltigen Abfällen wird hier genauer betrachtet. Ein Recycling von Kunststoffen impliziert, dass das gleiche Produkt wieder aus den Regranulaten produziert werden kann. Das ist leider bis heute so nicht möglich. Betrachtet man allein die Verdampfungsrate von Weichmachern bei Kunststoffen unterschiedlichen Alters oder auch die unterschiedliche Additivzugabe je nach Anwendungsbereich des Kunststoffes, wird dieser Zusammenhang deutlich. Post-Consumer Kunststoffe sind daher auch nach einer sortenreinen Trennung nicht recyclingfähig, sondern nur zum Downcycling geeignet.

Auch der Begriff „Bottle-to-Bottle“ beim PET-Flaschenrecycling bedeutet nur, dass ca. 15 % des Recycling-PET dem Roh-PET zur Produktion neuer Flaschen zugemischt werden kann. Die Zumischung von Regranulaten aus Produktionsabfällen zu Neuware ist der heute höchste Grad der werkstofflichen Verwertung. Aus Post-Consumer-Abfällen ist dies mit vertretbarem Aufwand und Zumischraten > 10 % zu Werkstoffen mit gehobenen Qualitätsansprüchen nicht möglich.

Werkstoffliche Verwertung bedeutet in der Regel die Produktion von dickwandigen Produkten, die dann spätestens nach dieser Nutzung endgültig thermisch beseitigt werden müssen. Diese Form der Verschiebung des Zeitpunktes der thermischen Beseitigung steht ökologisch und ökonomisch natürlich über einer Deponierung. Es bestehen heute auch in Deutschland nicht die MVA-Kapazitäten, um alle anfallenden Kunststoffe zu entsorgen. In Deutschland wurden 2007 ca. 15 Mio. t Kunststoffe verbraucht. Normiert auf die mittleren Heizwerte in MVA entspricht dies 60 Mio. t/a MVA-Kapazität. Wir haben aber heute nur < 20 Mio. t/a MVA-Kapazität. Die MVA-Kapazitäten können nicht in dem Maß erweitert werden, wie dies nach den Kunststoffproduktionszahlen der letzten Jahre und der mittleren Nutzungsdauer dieser Kunststoffe erforderlich wäre.

#### **5.4 Gesellschaftsdeponie**

Werden schadstoffbelastete Kunststoffe z.B. als Gartenpalisaden, Gartenbänke oder schwere Fahrradständer in der Gesellschaft vor der endgültigen Beseitigung zwischengelagert, bezeichnen wir dies als Gesellschaftsdeponierung. Die Gesellschaftsdeponie sichert den Kunststoffabfall für eine spätere geregelte Entsorgung.

#### **5.5 Thermische Beseitigung in MVA**

Der anerkannte Königsweg für die Entsorgung von kunststoffbelasteten Abfällen ist die MVA. Kunststoffe tragen mit 50 % bis 80 % zu den Kosten der MVA bei. Zwar sind die Kunststoffe nur zu 15 % bis 40 % im Abfall enthalten, aufgrund des hohen Heizwertes tragen diese Abfälle aber zu 50 % bis 90 % zur Feuerungswärmeleistung der Abfallverbrennung bei. Die Kosten der Abfallverbrennung sind im Wesentlichen von dem Volumen der angelieferten Abfälle, das die Logistik und die Kosten für Bunkerung und Beschickung der Verbrennung bestimmt, von der Feuerungswärmeleitung und von dem Schadstoffinventar abhängig. Die Massendurchsatzleistung spielt bei den Kosten der Abfallverbrennung eine untergeordnete Rolle. Eine Tonne kunststoffhaltiger Gewerbeabfall mit 16.000 kJ/kg verdrängt zwei Tonnen Hausmüll mit 8.000 kJ/kg. Der Betreiber der MVA hat bei Einsatz dieses kunststoffhaltigen Gewerbeabfalls nur die Hälfte der Einnahmen gegenüber der Hausmüllverbrennung. In Deutschland betragen die mittleren Kosten der Abfallverbrennung in den letzten 3 Jahren ca. 150 €/t bezogen auf einen mittleren Heizwert von 10.000 kJ/kg. Kunststoffe mit ca. 40.000 kJ/kg verdrängen 4 t Abfall mit 10.000 kJ/kg. Kunststoffe müssten theoretisch 600 €/t kosten, wenn diese als Monoabfälle verbrennbar wären, abzüglich der geringeren Kosten für die Schlackeverwertung. Heute gibt es jedoch noch keine MVA, die dauerhaft Heizwerte von 16 MJ/kg zulässt, Ausnahme ist z. B. die zirkulierende Wirbelschicht-Verbrennung (ZWS).

## 5.6 Deponierung

Kunststoffabfälle aus der Altautoaufbereitung und Restkunststoffe aus deponiertem MBA-Rottematerial werden auch in Deutschland noch offiziell deponiert. Im Ausland, mit Ausnahme weniger Staaten, ist die Kunststoffdeponierung immer noch der Hauptentsorgungsweg.

## 5.7 Export zur Scheinverwertung

Kunststoffabfälle werden offiziell zum größten Teil im Ausland werkstofflich verwertet. Erstmals wurde 2008 vom Bundeskriminalamt ein Bericht „Abfallwirtschaftskriminalität im Zusammenhang mit der EU-Osterweiterung“ veröffentlicht. Zitat: „Auf dem europäischen Entsorgungsmarkt ist von einem großen Dunkelfeld illegaler Verbringungspraktiken, insbesondere von so genannten „Scheinverwertungen“ auszugehen. Das Umweltgutachten 2002 des Sachverständigenrates kommt zu dem Schluss, dass die Scheinverwertung gängige Praxis ist und bezeichnet die abfallwirtschaftliche Entwicklung als eine Perversion der Abfallwirtschaft. Der Wegfall des Anschluss- und Benutzungszwanges bei Verwertungsmaßnahmen führte ferner zu einer erheblichen Steigerung des überregionalen und grenzüberschreitenden Transportaufkommens ...“.

Kunststoffabfälle stellen nach unserer Ansicht einen gefährlichen Abfall dar. Eine Gefährdung der Umwelt durch Kunststoffabfälle besteht langfristig und ist daher nicht unmittelbar wahrzunehmen. Es geht dabei nicht um eine akute toxische Wirkung, sondern um die Persistenz der Kunststoffe in der Umwelt.

Zwischen Kalifornien und Hawaii wurden 2004 mehrere Mio. Tonnen Kunststoffmüll auf dem Meer treibend entdeckt. Diese Kunststoffe werden nach und nach mechanisch zerkleinert und der Kunststoffanteil im Meeresplankton steigt messbar. Der Abbau und damit die Freisetzung der toxischen Inhaltsstoffe verlaufen über einen geschätzten Zeitraum von mehr als 500 Jahren.

Verschmutzungen von Luft und Wasser können innerhalb weniger Jahre behoben werden. Die Luftbelastung im Ruhrgebiet beispielsweise konnte durch Filteranlagen schnell wieder verringert werden. Die Verschmutzung der Umwelt durch Kunststoffe kann dagegen über 1000 Jahre andauern.

Das vordergründig bedeutendste Problem der Nutzung von Erdöl sind die CO<sub>2</sub>-Emissionen. Dieses Problem macht 90% der Ölnutzung aus und ist durch Nutzung nachwachsender Rohstoffe innerhalb von 50 bis 100 Jahren zumindest theoretisch lösbar. Die Kunststoffnutzung macht 10% des Rohölverbrauchs aus. Die Folgen eines nicht verantwortungsvollen Umgangs mit Kunststoffabfällen sind innerhalb der nächsten 1000 Jahre nicht umkehrbar.

## 6 Fazit

Kunststoffabfall ist kein Wertstoff. Die realen Systemkosten der Kunststoffproduktion und nachhaltigen Entsorgung sind grundsätzlich höher als die Verwendung von Grundstoffen wie Glas, Papier, Holz, Naturfasern, Stein, Metall usw.

Die Systemkosten fossiler Kunststoffe werden sich mit der zunehmenden Knappheit der Ressource Erdöl weiter erhöhen. Der Kunststoffverbrauch wird sinken, damit schränken sich auch die werkstofflichen Recyclingmöglichkeiten weiter ein.

Der Druck zur Scheinverwertung von Kunststoffabfällen kann nur gestoppt werden durch eine schnellstmögliche Entscheidung für einen Anschluss- und Benutzungszwang für kunststoffhaltige Abfälle zur Beseitigung.

## 7 Literatur

- |   |      |   |
|---|------|---|
| Achternbosch, M. et al.                         | 2004 | Auswirkungen des Einsatzes von Abfällen bei der Zementherstellung auf die Spurenelementgehalte von Zement und Beton. In: NACHRICHTEN - Forschungszentrum Karlsruhe Jahrg. 36 4/2004 S. 213-218  |
| Association of Cities and Regions for Recycling | 2004 | Empfehlenswerte Verfahren zum Recycling von Kunststoffabfall - Ein Wegweiser von und für lokale und regionale Behörden. Verlag : Jean-Pierre Hannequart. Download:<br><a href="http://www.pvch.ch/docs/PDF/VINYLGGER.pdf">http://www.pvch.ch/docs/PDF/VINYLGGER.pdf</a> |
| Brahms, E.; Eder, G.; Greiner, B.               | 1988 | Papier • Kunststoff • Verpackungen - Eine Mengen- und Schadstoffbetrachtung. Technische Universität Berlin, Berlin.   |
| Bundeskriminalamt (Hrsg.)                       | 2008 | Abfallwirtschaftskriminalität im Zusammenhang mit der EU-Osterweiterung. Wolters Kluwer Deutschland GmbH, Köln, ISBN 978-3-472-07156-3.   |
| Eder, G.  | 1992 | Wohin mit dem Kunststoffmüll? Werner-Verlag GmbH, Düsseldorf, ISBN 3-8041-14-33-4.  |
| Westerhoff, P. et al.                           | 2008 | Antimony leaching from polyethylene terephthalate (PET) plastic used for bottled drinking water. In: Water Research, 2008 Feb;42(3):551-556   |

**Anschrift des Verfassers:**

Dipl.-Ing. Reinhard Schu  
EcoEnergy Gesellschaft für Energie- und Umwelttechnik mbH  
Bei dem Gerichte 9  
D-37445 Walkenried  
Telefon +49 5525 2096-0  
Email [Reinhard.Schu@ecoenergy.de](mailto:Reinhard.Schu@ecoenergy.de)  
Website: [www.ecoenergy.de](http://www.ecoenergy.de)



# Innovative Waste Infrastructure Procurement in the UK – Separated Waste Services and Fuel Use Contracts

Euston Ling – Fuel Use Procurement Manager

Tim Judson – Procurement Director

North London Waste Authority

## Abstract

The North London Waste Authority has chosen to pursue an innovative approach to its procurement in order to maximise the environmental, social and financial performance of its waste management solution. As well as delivering the Authority's ambitions in diverting waste from landfill, this approach seeks to maximise the value of materials by recognising the resource value entrained in the waste stream, through the separate procurement of waste services to treat household waste for fuel production, and the utilisation of the resulting fuel to meet heat and energy demands. In pursuing a separated procurement, the Authority aims to attract as wide a market as possible for the fuel, ranging from large scale industrial users to smaller decentralised energy/district heating schemes, which would otherwise be excluded from a procurement of this nature.

## Keywords

UK, Waste, Procurement, PFI, Recycling, MBT, AD, MRF, HWRC, EfW

## 1 Authority Background

The Authority is the second largest waste disposal authority ("WDA") in the UK, handling around 3% of the national municipal waste (1.3 million tonnes per annum ("tpa")) by 2045).

The Authority is a statutory authority, which was established in 1986 after the abolition of the Greater London Council ("GLC"). Its prime statutory responsibility is for the disposal of waste collected by the seven north London boroughs of Barnet, Camden, Enfield, Hackney, Haringey, Islington and Waltham Forest (the "Constituent Boroughs"). The Constituent Boroughs are also the waste collection authorities ("WCAs").

For the past 15 years the Authority has managed its waste arisings predominantly through its waste treatment and disposal contract with LondonWaste Limited ("LWL") entailing the use of an EfW plant at a site in Edmonton. Due to the limited life of the existing EfW plant and a commitment to increase recycling rates and minimise impact on climate change the Authority must procure new services.

The Authority is therefore seeking to award a Waste Services Contract and a Fuel Use Contract(s) to one or more private sector partner(s) (respectively known as the “Waste Services Contractor” and the “Fuel Use Contractor(s)”), for the provision of a solution for the treatment of municipal solid waste (“MSW”). The Authority’s procurement will be divided into two lots. The Waste Services Contract will be procured under the first lot (“Lot One”) and the Fuel Use Contract(s) will be procured under the second lot (“Lot Two”). Under Lot Two, there will also be two additional sub-lots.

## 1.1 Functions and duties

The Authority’s statutory duties include:

- processing, treatment and disposal of waste collected by each of the Constituent Boroughs;
- management, transport and disposal of household waste from the household waste recycling centre (“HWRC”) network;
- storage and disposal of abandoned vehicles (this is currently delegated to the Constituent Boroughs);
- preparing a joint waste strategy for North London; and
- delivering performance that is consistent with statutory recycling and composting targets and diversion performance targets.

## 1.2 Geography and Population

North London is an area of approximately 30,000 hectares (“ha”). It is bounded by the M25 Motorway and Hertfordshire County Council to the north, Edgware Road and West London Waste Authority area to the west, the M11 Motorway and the East London Waste Authority area to the east, and by Westminster, the City of London and Tower Hamlets to the south. The table below outlines the area covered by each Constituent Borough:

*Table 1 Covered areas of each Borough*

<b>Borough</b>	<b>Area (ha)</b>
Barnet	8,677
Camden	2,178
Enfield	8,014
Hackney	1,904

Haringey	2,961
Islington	1,486
Waltham Forest	3,881
Total	29,101

The total population of the north London area is 1.7 million people who live in approximately 696,000 households. This population has increased from approximately 1.5 million in 1991 and, according to Greater London Authority (GLA) population estimates, is likely to rise by a further 150,000 by 2016 as part of a London-wide trend.

### 1.3 Analysis of Waste Arisings

The total waste arisings generated in the Authority area in 2008/09 was 904,440 tonnes. This was split on the following basis:

- residual waste (711,113 tonnes, 79% of total tonnage);
- dry waste (131,945 tonnes, 15% of total tonnage); and
- organic waste (61,082 tonnes, 6% of total tonnage).

### 1.4 Strategic Context

The Authority leads the development of the Joint Waste Strategy (JWS) which was adopted by the Constituent Boroughs in June 2008, providing the framework, appropriate management systems and resources to achieve all statutory performance standards and relevant new European Directives, national and regional targets and obligations to which the Authority and Constituent Boroughs are subject to.

The adoption of a JWS in north London has provided the opportunity for considerable analysis of the options, incorporation of stakeholder views and reflection of the changing national and regional policy framework. As adopted it provides a clear opportunity for the strong partnership working between Constituent Boroughs, the Authority and other stakeholders to continue and develop.

#### 1.4.1 JWS Aims and objectives

The key aims of the JWS are:

- to promote and implement sustainable municipal wastes management policies in north London;

- to minimise the overall environmental impacts of waste management;
- to engage residents, community groups, local business and any other interested parties in the development and implementation of the above policies; and
- to provide customer focused, best value services.

The key objectives of the JWS are:

- to minimise the amount of municipal waste arising;
- to maximise recycling and composting rates;
- to reduce greenhouse gases by disposing of less organic waste in landfill sites;
- to coordinate and continuously improve municipal waste minimisation and management policies in north London;
- to manage municipal waste in the most environmentally benign and economically efficient way possible through the provision and co-ordination of appropriate waste management facilities and services;
- to ensure that services and information are fully accessible to all members of the community;
- to maximise all opportunities for local regeneration; and
- to ensure an equitable distribution of costs, so that those who produce or manage the waste are responsible for paying for it.
- The JWS also sets out a series of implementation actions and policies in relation to:
  - waste prevention and minimisation;
  - recycling and composting;
  - diversion and landfilling of residual waste; and
  - environmental protection.

## **1.5 Current Collection and Disposal Arrangements**

The Constituent Boroughs have varied collection arrangements and systems. There is a broad split between Constituent Boroughs tending to collect co-mingled materials and those collecting source-separated materials. Some Constituent Boroughs are also now opting for hybrid systems under which paper is collected separately and other materials

co-mingled. Further distinctions exist between the systems for collecting organic waste and compulsion measures.

The relationship of the collection systems to disposal is the subject of review both collectively and within the Constituent Boroughs. It is agreed by the Constituent Boroughs in the principles of the Inter-Authority Agreement (“IAA”) that the Constituent Boroughs need to seek to promote similar arrangements which are conducive to higher levels of recycling. The Authority is working with the Constituent Boroughs to undertake a full review of future waste collection systems.

### **1.5.1 Household Waste Recycling Centres (HWRCs)**

North London is unusual in that the provision and operation of HWRCs has historically been the responsibility of the WCAs rather than the WDA. This has meant that some of the sites have a local service focus and target the more easily recyclable materials rather than the smart disposal of residual waste (eg. the use of waste wood that cannot be recycled as a biomass fuel source) and/or the recycling of material where volume is an issue (eg. plasterboard)

The Constituent Boroughs have agreed in principle, however, to transfer a property interest in and operation of the HWRCs to the Authority by the anticipated Contract commencement, October 2012 and as such the management of these facilities will form part of the new contractual arrangements.

Overall, the density of site coverage in some parts of the north London area means residents have to travel further than desirable to encourage frequent use of sites. This situation is causing congestion on key sites, leading to poor recycling performance and residents deciding to use alternative disposal routes.

An assessment of the current HWRC network performance has identified that the volume of material received is lower than expected, and that there is considerable scope for improving recycling rates. The Authority’s preliminary view is that with investment in new sites and the upgrading of existing sites would result in significant improvement in the performance of its HWRCs.

### **1.5.2 Current waste disposal contract**

The majority of waste that the Authority currently handles is managed through its current waste disposal contract with LWL. This contract is based on an incineration at Edmonton EcoPark and landfill, with a small amount of IVC. LWL is wholly owned by the Authority. This waste disposal contract will be terminated prior to the Authority entering into the Waste Service Contract.

### **1.5.3 Edmonton EcoPark**

The Ecopark, a waste management complex of around 16 ha is located within the London Borough of Enfield, close to its borders with the London Boroughs of Haringey and Waltham Forest. A total of 600,000 tpa of the municipal waste arising in the north London area was consigned to this site in 2008/09.

The EfW facility on the site has a capacity of circa 550,000 tpa, and was constructed by the GLC and opened in 1974. It receives all residual waste from the London Boroughs of Enfield, Haringey and Waltham Forest. A significant proportion of Hackney's residual waste is also accommodated together with small amounts from the other three Constituent Boroughs. The facility generates 55 megawatts ("MW") of electricity, 85% of which is exported from the site. Ferrous metals extracted from the resultant ash are sent for recycling and the remaining ash is consigned to an onsite ash recycling facility. The EfW supplies a relatively small amount of the excess heat generated to the Ecopark's autoclave facility.

Whilst a considerable amount of the Authority's residual waste delivered to the site is consigned directly to the incinerator (circa 250,000 tonnes in 2008/2009), a considerable proportion (circa 150,000 tonnes) is first treated onsite in either the Fuel Preparation Plant ("FPP") or the Bulky Waste Recycling Facility ("BWRP") to extract materials suitable for recycling. The Authority does not currently use the full capacity available at the EfW plant, the remainder of which is filled by municipal waste from other sources.

Around 30,000 tpa of the waste consigned to the site is treated in an IVC facility, producing a compost product which has been Publicly Available Specification "(PAS") 100 certified. The compost is made available for use by the Constituent Boroughs and for agricultural purposes. Despite its strategic role in raising the recycling composting rate of the NLWA's Constituent Boroughs over recent years, in terms of tonnage contribution, the IVC plays a relatively small role in the management of the Authority's waste which is dominated by the Edmonton EfW plant.

## **2 Reference Project**

The Authority conducted a full technical options appraisal which built upon the assessment of options within the JWS. The Authority has also conducted a particularly rigorous and comprehensive analysis involving a number of different technological scenarios. This appraisal considered a wide range of possible technical solutions and assessed these using a range of relevant criteria such as performance, sustainability and cost in order to identify a reference project. The carbon impact of solutions, using the Environment Agency's Waste and Resources Assessment Tool for the Environment ("WRATE") methodology was a key issue.

The technical options appraisal identified the need for a MRF, an AD facility and green waste composting facilities to deliver local and national ambitions on recycling. It also identified the need for a major upgrade of the HWRCs, both as a means to delivering recycling ambitions and improving the residual waste treatment solution.

On residual waste, the front runners were traditional EfW and mechanical biological treatment (“MBT”) with AD providing the biological treatment and with the process producing SRF. The Authority concluded that the second of these options provides a more appropriate reference project, as it provides a much better prospect of delivering a combined heat and power (“CHP”) solution, a better prospect in planning terms, an additional boost to recycling, and better prospects of bidders over-achieving against modelling assumptions.

On this basis the Authority selected the following, as its Reference Project within the context of a separated procurement for the Waste Services Contract and Fuel Use Contract(s).

*Table 2 Facilities of the Waste Services Contract and the Fuel Use Contract*

<b>Contract</b>	<b>Proposed facility</b>	<b>Number of proposed facilities</b>	<b>Capacity of facility</b>
Waste Services Contract	HWRCs	6 new facilities (additional refurbishment of some old sites)	6 sites totalling additional 29 ktpa
	IVC (existing)	1 facility	30 ktpa
	Green Waste Composting	1 facility	25 ktpa
	Rail Transfer Station (existing)	1 facility (West)	300 ktpa
	MRF	1 facility	100 ktpa
	AD	1 facility (East)	112 ktpa
	MBT-AD	2 facilities (East and West)	345 ktpa and 240 ktpa
Fuel Use Contract	SRF	1 facility (no site allocated)	320 ktpa

A key reason for conducting two separate procurements is to open up the fuel use to energy users who traditionally might not have any involvement with the waste industry and are able to derive value from SRF, by displacing fossil fuels for the creation of electricity and heat. This approach does not preclude waste management companies with energy production skills from putting forward solutions, but rather seeks to recognise that markets beyond the boundaries of the mainstream waste industry may in fact provide the optimal solution.



Responsibility for transport of fuel and outputs from the Waste Services Contract will fall within the main Waste Services Contract. In the event that fuel is transported, the Authority would wish to see as sustainable a transport solution as is possible and to this extent the Authority can facilitate via use of the existing Hendon rail transfer station or the wharf at the Edmonton site linked to the Lee navigation.

## 2.1 Costs, Budget and Finance

The Authority envisages that the procurements for the Fuel Use Contract(s) and the Waste Services Contract will be delivered under the UK Government's Private Finance Initiative (PFI). The relevant capital expenditure (in real terms) on the waste services infrastructure is £230.4 million and on the fuel use is £226 million.

## 2.2 Procurement Process

The overall procurement strategy developed for the Waste Services and Fuel Use Contracts takes into account the Authority's key requirements of: affordability and best value; deliverability; and sustainability.

Competitive Dialogue (CD) has been selected as the most appropriate European Union ("EU") tendering procedure for the contract. The Authority is mindful of the costly process that CD engenders and therefore is aiming to achieve an efficient process through to final tender. Accordingly, the Authority proposes to limit the number of stages with corresponding number of bidders as set out in the table below.

*Table 3 Stages of the Competitive Dialogue (CD)*

Stage	Comments
Pre- Qualification Questionnaire (PQQ)	The PQQ criteria have been drafted to ensure the short listing of a manageable number of bidders who are genuinely and demonstrably capable of developing and operating a facility of the scale and nature required by the Authority.
Invitation to Submit Out- line Solution (ISOS)	Due to the complex nature and scope of the fuel use procurement in relation to the acquisition of a site, preparation of a planning application, and identification of a preferred technology, a detailed ISOS response will be required from all bidders.
Invitation to Submit De- tailed Solu-	Following the initial dialogue, the submission of detailed solutions will be used to provide further clarity regarding how bidders' solutions meet the Authority's requirements, thereby allowing de-selection. The detailed solutions will concentrate on elements of bidders' proposals which are likely to be

tion (ISDS)	critical in evaluation.
Further Dialogue	Following de-selection resulting from the submission of detailed solutions, further dialogue will be used to develop the final solution together with all project documentation prior to the call for final tender. During this stage the Authority will test and define an approach to deal with all issues which could affect price or risk. This is likely to include substantial involvement from funders.
Final Tenders	On the close of dialogue, final tenders will be submitted for evaluation in accordance with the defined criteria, which will result in selection of a the contractor.

### 2.2.1 Evaluation

The dialogue process will be initiated by the issuing of a Pre Qualification Questionnaire (“PQQ”) to prospective bidders. Once pre-qualified, shortlisted bidders are subsequently to be invited to participate in the competitive dialogue process.

Shortlisted bidders shall be evaluated at various stages of the procurement against the Evaluation Framework to be issued with the ISOS. At each stage of the procurement a relevant set of submission requirements shall accompany each submission invitation such that bidders only submit the required information at each stage.

The Evaluation Framework shall form the basis for deselecting bidders throughout the procurement, through to the selection of a preferred bidder following the receipt of final tenders.

In the case of the procurement for the Fuel Use Contract(s), the Authority reserves the right before the start of the dialogue to limit the number of bidders it invites to participate in the dialogue in accordance with Regulation 18 (12) of the Public Contract Regulations 2006.

### 2.2.2 Form of Contract Documents

The draft Project Agreement and other associated contractual documents will adopt, so far as is applicable, the drafting and principles required by the UK Government’s Standardisation of PFI Contracts (SoPC4) or such replacement guidance as may be applicable at the time the contractual documentation is issued to bidders.

The Authority has sought to develop as simple a project as possible. This objective is likely to be achieved through the early identification of a preferred technology, acquisition of a suitable site, and development of a planning application for a reference project ahead of procurement. Derogations will therefore be limited to those widely recognised

in the waste sector such as those contained in DEFRA guidance “Standardisation of Waste Management PFI Contracts: Guidance on SoPC derogations” published in May 2006. Bidders will not be permitted to make derogations to the standard documentation that is proposed for non project-specific reasons.

The Authority is named as lead contracting authority in the OJEU Contract Notice and will be the contracting party to the project agreement. The IAA will sit behind the project agreement to govern the relationship between the Authority and the Constituent Boroughs.

### **2.2.3 Interface Between the Waste Services Contract and Fuel Use Contract(s)**

The procurements will remain separate. The call for final tenders will be staggered with the Fuel Use Contract(s) in advance of the Waste Service Contract to enable the destination of the fuel to inform the transport solution.

## **3 Waste Services Contract**

The fundamental objectives of the Services are to:

- Manage Contract Waste in a safe, efficient and effective manner;
- Manage Contract Waste to maximise recycling, composting and reuse, minimise the amount of Contract Waste to landfill and to produce SRF in the most efficient way possible; and
- Minimise the climate change of managing Contract Waste.

### **3.1 Scope of Waste Service Contract**

The Waste Services Contract covers:

- the design, construction, commission and financing of any additional facilities required for the provision of the service;
- the operation and maintenance of all facilities;
- the closure and replacement of two HWRCs, improvements made to two existing sites and the creation of three new HWRCs;
- the provision of at least four reception points for municipal wastes collected by the Constituent Boroughs. These will be either at the sites that the Authority has provided or within 2 km of those sites;

- the selection and securing of new sites, where they are not provided by the Authority;
- the treatment of all wastes including materials separately collected by the Authority's Constituent Boroughs in order to maximise the contribution to the Authority's 2020, 50% household waste recycling/composting target, divert waste from landfill to contribute to the Authority's 75%, 2020 landfill diversion target and produce SRF to a specific physio-chemical specification;
- the disposal of residues and waste not able to be treated as above;
- responsibility for the transport of all materials from reception points and HWRCs between project facilities to end users, markets, fuel users and/or final disposal;
- ensuring that appropriate and necessary consents including planning permission are in place for all sites and operations within the scope of this project;
- full responsibility for the outputs from all operations within the scope of this project including handling, management, marketing, sale and disposal;
- the provision of a service for the education of the local community and engagement with the community waste sector in order to facilitate socially beneficial reuse of durable items; and

The Authority envisages that the successful bidder will acquire shares in LWL from the Authority, which would see it take over responsibilities at Edmonton EcoPark, managing the existing assets including the EfW facility until the conclusion of its operational life.

The duration of the Waste Services Contract will be determined by the Authority through competitive dialogue, but it is expected to be for a period of between 25 to 35 years from financial close. The duration of the contract will be co-terminus with the Fuel Use Contract(s). The operational start date for the Waste Services Contract is anticipated to be 1 April 2016.

### **3.1.1 Sites**

Under the Waste Services Contract the Waste Services Contractor will be required to design, build, finance and operate certain waste treatment, processing and disposal facilities capable of processing approximately 1,300,000 tpa of MSW. As part of the Waste Services Contract, the Authority also requires the production of solid recovered fuel ("SRF"). It is envisaged that the facilities will produce approximately 320,000 tpa of SRF. Please see the Fuel Use Contract(s) section below for information relating to the treatment of the SRF produced.

The Authority has identified sites on which to locate its waste treatment, processing and treatment facilities, namely a site in Edmonton (in the Constituent Borough of Enfield), Pinkham Way (in the Constituent Borough of Haringey) and a site in Hendon near the Brent Cross Shopping Centre (in the Constituent Borough of Barnet). The sites comprise:

- **Edmonton:** The Reference Project proposes the following new facilities as well as the existing infrastructure located at the site: 345,000 tpa MBT (AD); 112,000 tpa AD. This site is located in the London Borough of Enfield.
- **Pinkham Way:** The reference project proposes a new 240,000 tpa MBT (AD). This site is situated in London Borough of Haringey.
- **Hendon:** The site is identified for a 100,000 tpa MRF to support the Authority's proposals. The local authority is the London Borough of Barnet.

## 4 Fuel Use Contract

The fundamental objective of the Fuel Use Contract is to accept SRF from the North London Waste Authority (the "Authority") and use it in a cost effective manner to generate energy in order to minimise the climate change impact of managing municipal solid waste through effective diversion from landfill in the most efficient means possible.

The Authority wishes to procure a fuel use solution(s) that delivers the best environmental, financial and commercial terms in a way that maximises the prospect of early delivery. This solution is intended to fulfil the following environmental, financial, commercial and deliverability objectives:

1. the Authority's environmental considerations include the creation of ongoing landfill diversion capacity and improved carbon impact of using the SRF, including any transport. It is hoped that the best overall environmental solution will incorporate good quality CHP solutions which lead to substantial heat use;
2. the Authority's primary financial consideration is the cost of building the plant and the associated gate fee payable by the Authority to the energy user. This fee should include benefits from the sale of energy and any other financial benefits such as ROCs, ECAs, RHIs along with any other carbon benefits such as carbon trading;
3. the Authority's key commercial considerations include: risks associated with design, build, finance and operation of the facility(ies); certainty over SRF markets; realising the residual value of facility(ies) at the end of the contract; and what might happen in the event of a failure.

Deliverability considerations will need to take into account not only the likelihood of establishing a solution and the timescales involved, but also the contribution that the solution makes to the wider community in terms of place shaping and regeneration, employment opportunities and synergy with sub-regional or regional sustainable development in the context of potential planning considerations.

#### **4.1 General**

The OJEU notice contains the following two sub-lots for bidders to bid for:

- (a) Sub-Lot 1: 130,000 to 170,000 tpa; and
- (b) Sub-Lot 2: 280,000 to 340,000 tpa.

The Authority may, at its discretion, award two contracts under Sub-Lot One. If only one lot of 130,000 to 170,000 tpa under Sub-Lot One is successfully awarded, the Authority reserves the right to carry out a new procurement for the remaining SRF in 2018 (for service commencement operation by 2020) and the remaining SRF Tonnage produced under the Waste Services Contract is expected to be disposed of by the Waste Services Contractor.

A bidder may put forward proposals for any combination of sub-lots (2 times sub-lot 1; or sub-lot 1 and sub-lot 2), provided each proposal relates to a different solution and different site.

#### **4.2 Scope of Fuel Use Contract(s)**

The Fuel Use Contract(s) will potentially involve the design, build, finance and operation of an EfW facility or the use of a merchant facility to utilise approximately 320,000 tpa of SRF produced under the Waste Services Contract. The operational start date for the Fuel Use Contract(s) is anticipated to be 1 April 2017.

The Waste Services Contractor will be responsible for the provision and transfer of SRF to the Fuel Use Contractor(s) and the operational start date for the Fuel Use Contract(s) is anticipated to be 1 April 2017.

The duration of the Fuel Use Contract(s) will be determined by the Authority through competitive dialogue, but it is expected to be for a period of between 25 to 35 years following the commencement of production of the SRF under the Waste Services Contract. The duration of the contract will be co-terminus with the Fuel Use Contract(s).

#### **4.2.1 Technology**

The Authority is seeking solutions which derive the maximum economic and environmental benefit from the SRF by displacing fossil fuel use for the creation of electricity and heat as part of its overall waste strategy. To facilitate this, the Authority has adopted a strategy that is broadly and deliberately technology neutral. Notwithstanding this, the Authority is seeking a proven technology solution(s) in respect of its operational status, reliability and flexibility.

In doing so, the Authority is endeavouring as far as is practicable to facilitate the delivery of a CHP solution. It is the Authority's view that a separated procurement strategy provides greater opportunity for realising CHP solutions as it allows industrial energy users to supply their production processes by using SRF to displace fossil fuels. At the same time, the strategy provides an opportunity for local urban regeneration projects to satisfy London (or other) planning guidance on renewable energy whilst delivering CHP solutions.

Whilst the Authority will require a degree of flexibility in respect of the SRF tonnage capable of being processed in any given period, the Fuel Use Contract is likely to specify a guaranteed minimum tonnage of SRF that meets a pre-determined specification.

#### **4.2.2 Sites, Planning and Design**

The Authority's procurement approach recognises that the solution for the fuel use procurement needs to be located close to the intended energy use and that it makes sense for the fuel use provider to provide the relevant site, rather than the Authority to do so. The Authority has not therefore sought to provide a site to support the Fuel Use Contract. On this basis the Authority will require bidders to propose their own site solutions in putting forward their fuel use solutions.

#### **Author's addresses:**

Euston Ling – Fuel Use Procurement Manager

Tim Judson – Procurement Director

North London Waste Authority

Lee Valley Technopark

Unit 360, Ashley Road

London N17 9LN

Telephone: + 44 (0) 20 8489 5752



Email: [euston.ling@nlwa.gov.uk](mailto:euston.ling@nlwa.gov.uk)  
[tim.judson@nlwa.gov.uk](mailto:tim.judson@nlwa.gov.uk)

Website: [www.nlwa.gov.uk](http://www.nlwa.gov.uk)

# Formel für die Energieeffizienz - Bedeutung und Anwendung

Walter Hauer

Technisches Büro HAUER Umweltwirtschaft GmbH

## Formula for Energy Efficiency – Meaning and Application

### Abstract

The EU-Directive on Waste provides for the classification of waste incineration as a recovery from the so-called energy efficiency. The value represents a comparison, but not the efficiency. State of the art facilities exceed the threshold most part; a waste incineration represents in accordance with the EU Directive usually an "other recovery". For the practical application of the formula, clear guidelines, in particular for the system boundaries, are required. Currently there is considerable room for interpretation.

### Inhaltsangabe

Die EU-Richtlinie über Abfälle verwendet zur Einstufung der Abfallverbrennung als Verwertung die so genannte Energieeffizienz. Der Wert stellt einen Vergleichswert, aber keinen Wirkungsgrad dar. Dem Stand der Technik entsprechende Anlagen überschreiten den Schwellenwert großteils; eine Abfallverbrennung wird daher gemäß EU-Richtlinie meist eine „sonstige Verwertung“ darstellen. Für die praktische Anwendung der Formel sind noch eindeutige Richtlinien, insbesondere zu den Systemgrenzen, erforderlich. Derzeit besteht erheblicher Interpretationsspielraum.

### Keywords

Abfallverbrennung, Energieeffizienz, Thermische Verwertung, EU-Richtlinie über Abfälle

Waste Incineration, Energy Efficiency, Thermal Utilisation, Keywords, EU-Directive on Waste

## 1 Was sagt die Energieeffizienz aus

In der EU-Richtlinie über Abfälle wird für die Art der Behandlung von Abfällen in einer Abfall-Verbrennungsanlage als Beseitigung (D10) oder als Verwertung (R1) auf die so genannte *Energieeffizienz* der jeweiligen Behandlungsanlage abgestellt. Zur Ermittlung der Kennzahl wurde eine Formel in den Anhang II der Richtlinie aufgenommen:

$$\text{Energieeffizienz} = \frac{E_p - (E_f + E_i)}{0,97 * (E_w + E_f)}$$

Dabei ist  $E_p$  die jährlich als Wärme oder Strom erzeugte Energie.

Um eine Vergleichbarkeit zwischen Anlagen herzustellen die entweder nur Wärme liefern oder nur elektrische Energie oder beides, wurden Faktoren vorgegeben, die den

Umsetzungsgrad von thermischer Energie zu elektrischer Energie berücksichtigen. Nach Einsetzen dieser Faktoren lautet die Formel:

$$\text{Energieeffizienz} = \frac{(1,1 * E_{th} + 2,6 * E_e) - (E_f + E_i)}{0,97 * (E_w + E_f)}$$

Dabei sind:

- $E_w$  die jährliche Energiemenge, die im behandelten Abfall enthalten ist
- $E_e$  Elektroenergie
- $E_{th}$  für gewerbliche Zwecke erzeugte Wärme
- $E_f$  der jährliche Input von Energie in das System aus Brennstoffen (Anm.: ohne Abfälle)
- $E_i$  die jährliche importierte Energiemenge

Die Faktoren 1,1 für Wärme und 2,6 für elektrische Energie sowie der allgemeine Faktor im Nenner von 0,97 normieren auf Wirkungsgrade bzw. Umsetzungsgrade durchschnittlicher Industrieanlagen:

- Auf einen Wirkungsgrad für Wärme von 88,2% ( $= \frac{1}{1,1} * 0,97$ )
- Auf einen Umsetzungsgrad in elektrische Energie von 37,3% ( $= \frac{1}{2,6} * 0,97$ )

Im Vergleich dazu gibt der Energiestatus Österreich 2008 für kalorische Kraftwerke einen durchschnittlichen Umsetzungsgrad von 42% an.<sup>1</sup> Für Kraft-Wärme-Kopplungen wird ein durchschnittlicher Wirkungsgrad für Strom und Wärme von 65% angegeben. Für diesen Wert wird die Brutto-Stromerzeugung (inklusive Eigenverbrauch) und die Netto-Wärmeerzeugung (exklusive Eigenverbrauch) herangezogen. Auf diese Abgrenzung komme ich später wieder zurück.

Mit den Faktoren 1,1, 2,6 und 0,97 stellt die Formel auf einen Vergleich mit durchschnittlichen Industrieanlagen ab. Das Ergebnis der Formel stellt eben diesen Vergleich mit Industrieanlagen dar. So sagt z.B. ein Ergebnis für die Energieeffizienz von 0,7 aus, dass die Abfallverbrennungsanlage einen Wirkungsgrad hat, der bei 70% jener einer mittleren Industrieanlage bzw. eines mittleren Kraftwerkes hat. Der tatsächliche Wirkungsgrad liegt darunter.

Anders betrachtet gibt die Formel an, welche Energiemenge aus Primärenergieträgern durch die Verbrennung von Abfällen substituiert wurde. Im oben genannten Beispiel einer Energieeffizienz von 0,7 wurden mit dem Einsatz von Abfällen eben 70% der

<sup>1</sup> Bundesministerium für Wirtschaft und Arbeit (Hrsg.): Energiestatus Österreich 2008, S. 37

Primärenergie eingespart, die bei Bereitstellung der Energie aus Primärenergieträgern erforderlich gewesen wäre.

In der folgenden Abbildung ist ersichtlich, welche Wirkungsgrade Abfallverbrennungsanlagen im Vergleich zu Industrieanlagen erreichen müssen, um eine Einstufung der Behandlung als Verwertung zu erreichen. Das sind für Neuanlagen 24% für elektrische Energie und 57% für Wärme. Für bestehende Anlagen reduzieren sich die Werte auf 22% bzw. 53%.

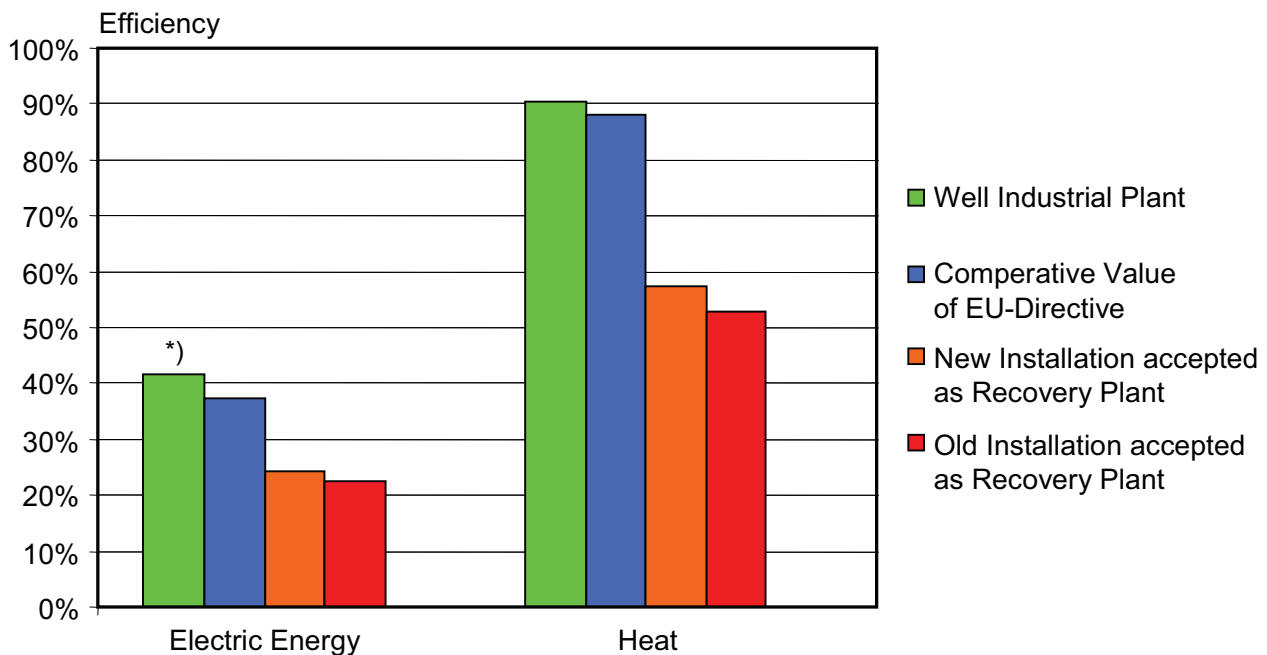

\*) Der Durchschnittswert für die kalorischen Kraftwerke in Österreich beträgt 42%

Abbildung 1 Fließbild aus dem BAT-Referenzdokument „Waste Incineration“ (Abb. 10.14)

## 2 Systemgrenzen

Zur Anwendung der Formel verweist die EU-Richtlinie auf das Referenzdokument zu den besten verfügbaren Techniken für die Abfallverbrennung.<sup>2</sup> In diesem Dokument wird festgelegt, dass folgende Prozesse immer zum System der Abfallverbrennung gehören und damit jedenfalls berücksichtigt werden müssen:

- Thermischer Prozess
- Energieumwandlung
- Rauchgasreinigung

<sup>2</sup> Europäische Kommission (Hrsg.): Integrated Pollution Prevention and Control Reference Document on the Best Available Techniques for Waste Incineration, Brüssel 2006

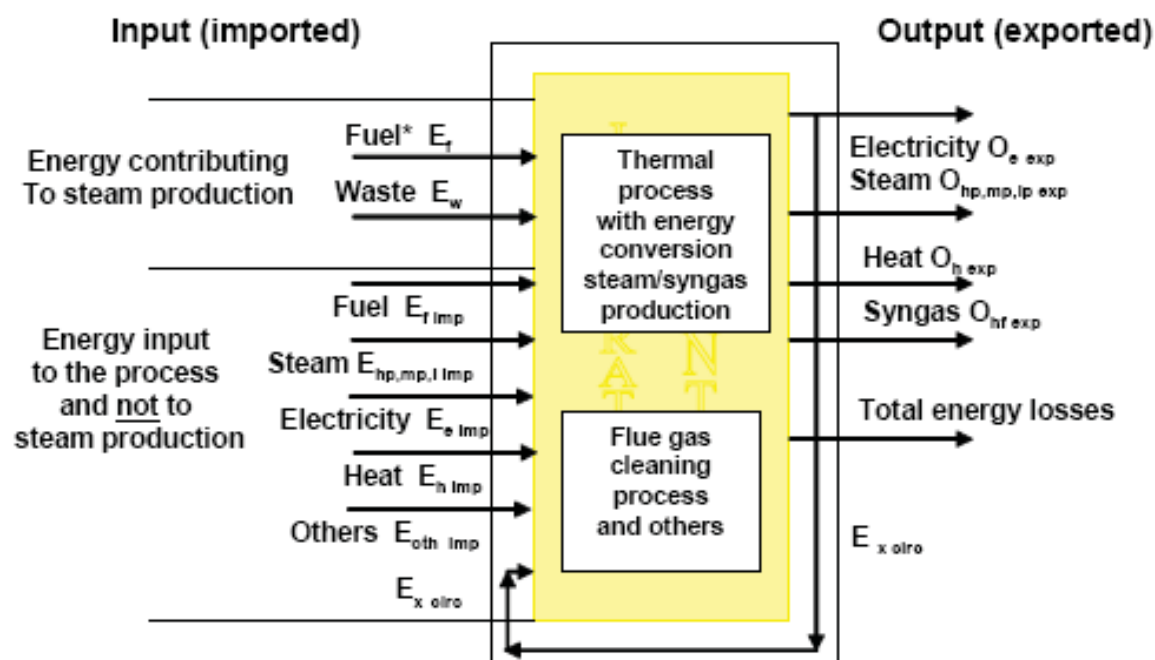

\* e.g. fuel for auxiliary burners

Abbildung 2 Fließbild aus dem BAT-Referenzdokument „Waste Incineration“ (Abb. 10.14)

Im der EU-Richtlinie werden die Systemgrenzen je nach Art der Energie unterschiedlich gezogen:

Elektrische Energie wird zur Gänze als *Elektroenergie* bezeichnet. Somit ist auch der Eigenverbrauch der Anlage als Nutzenergie zu sehen. Dies deckt sich mit der Sichtweise der Betreiber kalorischer Kraftwerke, wo die Bruttoerzeugung betrachtet wird (siehe oben).

Wärme wird insoweit als Nutzenergie berücksichtigt, als sie für *gewerbliche Zwecke* genutzt wird. Hier ist strittig, ob der Eigenverbrauch als für *gewerbliche Zwecke genutzt* bezeichnet werden kann. So könnte man interpretieren, dass intern genutzte Energie z.B. zum Aufheizen der Rauchgase auch gewerblich genutzt würde. Andere Anwendungen wie z.B. zum Beheizen der Betriebsräume entsprechen eher der Begrifflichkeit *gewerblich genutzt*.

Die Unterschiede in den Ergebnissen sind je nach Festlegung unterschiedlicher Systemgrenzen jedenfalls eklatant, wie folgendes Beispiel für die Werte der Energieeffizienz für zwei Anlagen zeigt.<sup>3</sup>

<sup>3</sup> Österreichischer Wasser- und Abfallwirtschaftsverband (Hrsg.): ÖWAV-Regelblatt 519 Energetische Wirkungsgrade von Abfallverbrennungsanlagen, S. 25

NETTO: Betrachtung exportierter Energien (Nettoenergiemengen)

NETTO/BRUTTO: Betrachtung der elektrischen Energie brutto (Generatorklemme) und der exportierten Wärme netto

BRUTTO 1: Betrachtung der elektrischen Energie brutto und der Wärmemenge brutto inklusive Eigenbedarf gemäß BAT-Dokument

BRUTTO 2: Betrachtung der Brutto-Wärmemenge inklusive Eigenbedarf (elektrisch und thermisch) sowie intern rezirkulierter Wärme (z.B. zur Speisewasser- oder Luftvorwärmung)

*Tabelle 1 Auswirkung unterschiedlicher Systemgrenzen auf den Wert für die Energieeffizienz*

	<b>NETTO</b>	<b>NETTO / BRUTTO</b>	<b>BRUTTO 1</b>	<b>BRUTTO 2</b>
überwiegende Abgabe von elektrischer Energie	0,60	<b>0,70</b>	0,73	0,91
überwiegende Abgabe von Wärme	0,74	<b>0,80</b>	0,89	0,94

Gemäß meiner Interpretation der EU-Richtlinie, ist die Betrachtung NETTO/BRUTTO anzuwenden. Mit dieser Betrachtung wird dem Sinn der Formel – Messung der Substitution an Primärenergieträgern - am ehesten entsprochen. Durch Verwendung von Energie für den Betrieb einer Abfallverbrennungsanlage (BRUTTO-Betrachtung) wird keine Primärenergie in anderen Energieerzeugungsanlagen / Kraftwerken gespart.

Die NETTO/BRUTTO-Betrachtung deckt sich auch weitgehend mit der bei konventionellen Kraftwerken und Kraft-Wärme-Kopplungen gebräuchlichen Betrachtung.

Die Anlage mit überwiegender Abgabe elektrischer Energie mit einem Wert für die Energieeffizienz von 0,70 kommt unter Berücksichtigung der in der Formel der EU-Richtlinie angewandten Faktoren auf einen Gesamt-Wirkungsgrad von rund 26%. Die MVA Asdonkshof erreicht vergleichsweise einen Wert für die Energieeffizienz von 0,83 bei einem Wirkungsgrad von knapp über 30%.<sup>4</sup>

Tabelle 1 zeigt auch anschaulich, dass für das Erzielen hoher Werte für die Energieeffizienz das Auskoppeln von Wärme hilfreich ist.

<sup>4</sup> Bollig, P.: Energieeffizienzbetrachtung am Beispiel der MVA Asdonkshof, Referat zum Symposium Beitrag der Abfallwirtschaft zum Klimaschutz, Duisburg, 26.10.2007

### 3 Beispiele

Dem Autor liegen aus verschiedenen Anlagen aus Deutschland, der Schweiz und aus Österreich Daten zur Energieeffizienz vor. Dabei wurden auch Kombinationen aus mechanisch-biologischen Behandlungen mit anschließender energetischer Nutzung der heizwertreichen Fraktionen in Wirbelschichtanlagen in den Vergleich mit einbezogen.

Die Ergebnisse zeigen einen Wertebereich von 0,4 bis 0,5 für die Kombination mechanisch-biologischer Abfallbehandlungsanlagen mit anschließender Verbrennung heizwertreicher Fraktionen in Abfallverbrennungsanlagen. Die Werte für Rostfeuerungen lagen je nach Anlage, Energienutzung und Systemgrenze zwischen 0,6 und 0,8. Eine Wirbelschichtfeuerung erreichte den Wert 0,84. Bei einer Mitverbrennung ausgewählter Fraktionen in einem modernen kalorischen Kraftwerk hat sich ein Wert größer 1 ergeben.

Bei genauer Betrachtung der Berechnung der Werte für die Energieeffizienz wurde deutlich, wie schwierig das Einhalten gleicher Systemgrenzen ist. Werden jedoch die Systemgrenzen unterschiedlich gezogen, so ist die Vergleichbarkeit der Werte nicht mehr gegeben. Beispielhaft sei die Argumentation angeführt, dass ja der Zweck einer Müllverbrennungsanlage primär die Inertisierung der Abfälle ist. Demnach wäre jede Nutzung von Energie auch innerhalb der Anlage z.B. zum Betrieb von Pumpen oder zum Aufwärmen von Rauchgasen eine Substitution von Primärenergie, da die Anlagen jedenfalls betrieben werden müssten, auch wenn sie keine Energie (für sich selbst) liefern würden. Diese Betrachtung führte dazu, dass in vielen Fällen der Wert für die Energieeffizienz nach der oben beschriebenen Methode BRUTTO 1 ermittelt wurde.

Die betrachteten Verbrennungsanlagen erreichen mit einem Wert größer 0,6 (für Altanlagen) alle den Status einer „Sonstigen Verwertung“<sup>5</sup>. Moderne Anlagen erreichen auch ohne Wärmeauskoppelung (nur mit Umwandlung in elektrische Energie) den geforderten Mindestwert für Neuanlagen von 0,65.

### 4 Kritische Würdigung und Zusammenfassung

Die Formel für die Energieeffizienz ermöglicht einen Vergleich zwischen verschiedenen Anlagen, und zwar unabhängig ob die Anlage Brennstoffe oder Abfälle verbrennt und unabhängig in welcher Form die Anlage Energie abgibt – ob in Form elektrischer Energie und/oder in Form von Wärme oder Dampf.

---

<sup>5</sup> gemäß EU-Richtlinie über Abfälle, Artikel 4 „Abfallhierarchie“, Abs. 1



Es muss eindringlich und deutlich darauf hingewiesen werden, dass der **Wert für die Energieeffizienz keinen Wirkungsgrad** im thermodynamischen Sinn darstellt, dass der Wert lediglich einen Vergleich zu anderen Anlagen ermöglicht.

Zu wünschen ist, dass für die weitere Anwendung der Formel rasch eindeutige Richtlinien zu deren praktischer Anwendung, insbesondere zur Festlegung der Systemgrenzen herausgegeben werden. Hier besteht für eine Vergleichbarkeit von Ergebnissen ein zu hoher Interpretationsspielraum.

## 5 Literatur

- |   |      |  |
|---|------|--|
| Bollig, P   | 2007 | Energieeffizienzbetrachtung am Beispiel der MVA Asdonkshof, Referat zum Symposium Beitrag der Abfallwirtschaft zum Klimaschutz, Duisburg |
| Österreichischer Wasser- und Abfallwirtschaftsverband (Hrsg.) | 2010 | ÖWAV-Regelblatt 519 Energetische Wirkungsgrade von Abfallverbrennungsanlagen   |
| Bundesministerium für Wirtschaft und Arbeit (Hrsg.)           | 2008 | Energiestatus Österreich   |
| Europäische Kommission (Hrsg.)                                | 2006 | Integrated Pollution Prevention and Control Reference Document on the Best Available Techniques for Waste Incineration                   |

### **Anschrift des Verfassers:**

Ing. Mag. Walter Hauer  
Technisches Büro HAUER Umweltwirtschaft GmbH  
Brückenstraße 6  
A-2100 Korneuburg  
Telefon +43 2262 62223  
Email [tbhauer@tbhauer.at](mailto:tbhauer@tbhauer.at)  
Website: [www.tbhauer.at](http://www.tbhauer.at)

# Increasing energy efficiency: A plant manufacturers view

Mariusz Maciejewski

Keppel Seghers Belgium NV / Willebroek (B)

## Abstract

To increase the energy efficiency of the waste-to-energy plants is the main challenge of each plant manufacturer. This article lists some current trends and picks- up three of them by mean of examples from current Keppel Seghers projects.

## Keywords

Energy efficiency, waste management, RDF, CHP, dry FGC,

Energieeffizienz, Abfallmanagement, EBS, KWK, Trockene Abgasreinigung

## 1 Introduction

Whereas Waste-to-Energy plants of the 'first-generation' (built in the 1980s) were conceived as stand-alone facilities with the main purpose to get rid of waste, plants of later construction dates started to contain technical solutions to reduce (excessive) energy losses. The electricity produced however was still regarded as a by-product at most of WtE-sites. Modest plant (gross) efficiencies < 24% can be easily understood since the income of those WtE-plants – mostly owned and operated by authorities – was by far more dependent on gate fees than on revenues from electricity sale. As in a public context gate fees are indirectly being paid by the community through taxes or contributions on garbage bags, the viability of WtE-plants is in fact secured without a strong need for optimizing the energy output.

With climate issues currently gaining strong importance worldwide, focus is clearly set on increasing the energetic efficiency of industries and hence significantly reducing carbon footprints. In this article main trends of energy optimization are presented and three of them, used shortly by Keppel Seghers, will be described in detail.

## 2 Some methods of energy optimization

When observing the market some trends of energy optimization are existing, used more or less consequently by different technology suppliers. In this article some of them are being presented, starting with the beginning of the incineration process.

One of the main questions, when discussing about waste-to-energy plants is: are there any alternatives to burning waste? The mechanical-biological-treatment MBT is easy,

cheaper than incineration and more accepted among politicians and citizens. There is only one right answer to this question: “yes, but ....” Even in the MBT after metals, inters and organic fractions are removed there is still more than 40% waste fraction left for treatment. This higher energetic waste, called refuse-derived fuel (RDF) can be used as input stream to the waste-to-energy plant making this system perfect. The enhanced quality of RDF, with high LHV > 11 MJ/kg, low chlorine content and only few inters allows operation of high-caloric incineration plant. We call it integrated waste management. An example of a successfully integrated waste management centre in Qatar is described in the block 2.1.

In addition to the high calorific value, RDF offers the good homogeneity, enabling smooth combustion on the grate. The constant thermal energy output and no emission peaks are the comfortable conditions for plant operators. The situation changes completely when using mixed waste. Depending on the waste composition, LHV, moisture, size and ash content change permanently. This is a challenge for the “state of the art” combustion control system. The control refers to all the equipment included in the combustion process i.e. furnace flue gas side, grate drive with hydraulic system, grate cooling, ash extractor, primary and secondary air, commands of the burners. The main aim is to achieve constant energy output and emission data inside of possible grate and boiler process tolerances. Thanks to high developed computer models it is possible to operate the plants on the cutting edge, however there is still room for improvement.

A new trend can be observed in Switzerland. Due to special landfill regulation concerning bottom ash, a special dry ash extractor has been developed by one of technology suppliers. The technical description of this process is not a part of this article. From the economical point of view savings from better bottom ash quality, also lower disposal cost and additional revenues coming from better metal recycling are expected. The tests are still running and it is too early to decide, if this technology will be interesting for plants in other countries.

The boiler, heart of the energy system offers high potential for increasing the energy efficiency. Since waste-fired boilers are design limited at high temperatures (due to Cl-induced corrosion near the superheating section) it is important to maximally exploit the low-temperature end of the WtE-process in terms of heat recovery. Here the corrosion by condensed SO<sub>2</sub> is considered an important parameter for design. An ensemble of flue gas conditions i.e. bulk gas temperature, partial pressure of SO<sub>2</sub>(g) and % of moisture is determining for the (theoretical) dew point. Whether the condensation of SO<sub>2</sub> into aqueous H<sub>2</sub>SO<sub>4</sub> droplets is effectively induced in the economizer section depends on the temperature of the tube contact surface and hence the boiler feedwater entering those tubes. For this reason WtE-boilers are up until now often designed with >130°C boiler feed water (BFW) temperature. Apart from experimental evidence, Keppel Segh-

ers also builds on long time plant-scale experience with reduced boiler exit temperatures, strongly supporting the feasibility of a boiler concept with reduced outlet temperatures. Keppel Seghers references in Romonta (Amsdorf, Germany) and Newlincs (Grimsby, UK) are to be mentioned in this regard.

Clearly there is still a way to go if WtE-boilers are to be brought up to the efficiency level of power plant boilers. The strategy that crosses the mind in first instance is to create power plant 'look-a-likes' by applying increased steam parameters. Chlorine-induced corrosion is however complicating this strategy. An important part of the research by the "NextGenBioWaste"-network (funded by the European Commission under the "6th Framework Programme") brings together knowledgeable partners from throughout Europe to tackle a.o. this challenge. Ongoing R&D by (German) scientists, specialized companies and a limited number of plant operators helps to get a better understanding of Cl- and S-corrosion chemistry. In particular tools and methods to assess potential plant-scale corrosion damage in an early stage are interesting from a practical and design perspective. Steady progress is made in the development of boiler materials that allow raising the superheated steam parameters gradually above the WtE- 'standard' of 40 bar &  $\pm 400^{\circ}\text{C}$  in a sustainable and cost-effective way. Issues of particular importance in this regard are a.o. the iron content, Ni/Cr-ratio and application method accuracy of protection materials (inconel and spraycoating), composition of boiler tube steels. The current "state-of-the-art", superheated steam temperatures up to max.  $430^{\circ}\text{C}$  are considerable for a WtE-plant as economically sensible, thereby assuming the lifetime of superheaters not being sacrificed below two years. Obviously this is not to be generalized as market rates for waste, residues disposal, consumables, electricity, energy etc. – influencing the economical plant models – are everywhere different. Extreme parameters like in Amsterdam WFPP (130 bar /  $480^{\circ}\text{C}$ ) are possible, however causing high investment costs as well as problems during commissioning and operation. The practical experience shows, whether this is the right way to improve energy efficiency.

A high potential for efficiency increase can be also found in the turbine. The improvements inside the steam turbine are the challenges for turbine manufacturers, but the turbine environment plays an important role for the total efficiency. In addition to the above mentioned higher steam parameters the condensate parameters can be reduced. This is possible by using water-cooled condensers, allowing steam condensation near vacuum i.e. 70 mbar /  $39^{\circ}\text{C}$ . The pre-condition for this method is the availability of closed or open cooling water circuit.

A significant strategy for future WtE-plants consists of building them in industrial areas, i.e. bring them to intensive energy consumers, where they can be maximally exploited as sources of industrial power. It allows 'upgrading' WtE-plants at once up to potential efficiency levels of 90%, i.e. about 3.5 times the current efficiency of an average 'stand

alone' WtE-facility. The need of society to get rid of the waste can be consolidated in this way with the industrial need for energy. Political and public acceptance is likely to increase as WtE's are being moved further away from residential areas and the treatment of industrial & commercial waste can be addressed at once by co-combustion in the plants. Operating a WtE as highly efficient CHP and selling also steam & heat to surrounding consumers further boosts up the profitability. An example of successfully built CHP in Amtfors/S is described in the block 2.2.

The overall energetic efficiency of WtE-plants can be also increased by optimizing the interface between boiler and flue gas cleaning. Experimental and medium-plant scale evidence support the possibility for reducing boiler outlet temperatures below the currently accepted 'standards'. Due to actual developments in EU energy policy, the chemical performance of flue gas cleaning systems needs to be more and more consolidated with thermal performance. Furthermore, striving for a high performance does not per definition require a complicated system. An all-dry FGC system coupled with a low-temperature boiler exit offers a financially interesting solution, combining gas cleaning performance and increased energetic efficiency with improved plant availability. An example of dry FGC system constructed in Runcorn/GB is described in the block 2.3.

## **2.1 Example: IWMC / Qatar**

More and more countries around the world are limiting or even banning landfill, driving alternative waste solutions towards combinations of maximum recycling and alternative energy generation. The concept of "integrated waste management" is now emerging as mature strategy to cope with the ever- growing complexities of handling large volumes of solid waste. In an integrated waste management the concept of "waste" is replaced by a concept of "resource", combined with well-organized and controlled waste stream. A modern integrated waste management policy is based on combination of waste prevention and avoidance, maximized recycling of used goods, waste re-use, sorting an separate waste collection. Such a concept automatically results in minimized landfilling leaving only a final amount of municipal solid waste (MSW) for further treatment.

Integrated waste management centers separate the MSW into very specific remainder fractions, allowing optimal recycling and/or energy recovery of each specific waste stream. The organic fraction of the waste in an integrated waste management centre is sent to an aerobic or anaerobic process for recycling through composting and energy capture via digestion to biogas. The non-organic fraction that cannot be recycled or used for energy production from composting or digestion is considered for heat and/or generation through thermal production processes. This residual waste has an average heating value of about 15 MJ/kg and is called refuse-derived fuel (RDF). Other fractions such as inert steel, aluminum and ash residues are recycled from the municipal waste

or re-used as sand or granulate for a multitude of construction purposes, as (non)-ferrous metals, as industrial salt, gypsum etc. Dedicated technologies ensure that every last fraction of the waste can be re-used.

In this way, in an integrated waste management centre, waste as resource is not only converted into valuable electricity and heating. It's a total and sustainable solution turning each waste fraction into most valuable resource.

Keppel Seghers is currently starting the first IWMC in the Middle East, in Qatar. After the final commissioning in 2010, 1.550 of waste per day will be recycled, composted and turned into energy, resulting in 180.000 MWh/a electricity. The schematic overview below shows the different elements of a typical IWMC.

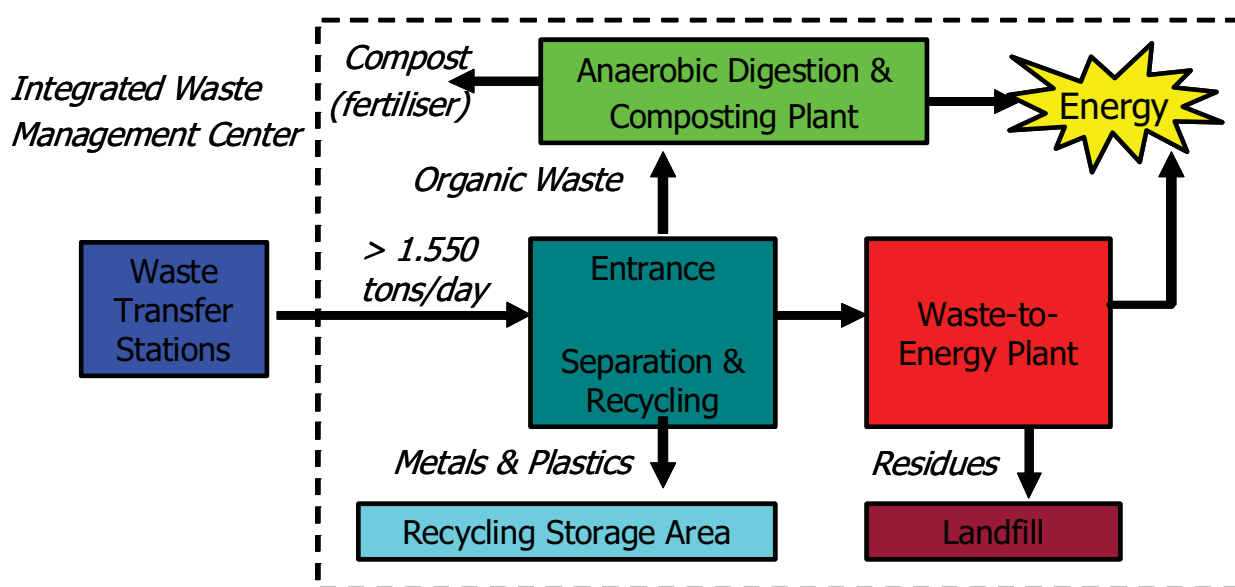

Figure 1 Integrated Waste Management Center as implemented in Doha (Qatar).

### 2.1.1 Waste reception

Waste enters the facility through the waste reception area and is stored in a bunker, sized to allow for adequate storage during peak delivery times. It is then transferred via an overhead crane to be treated mechanically through several size and density sorting processes.

### 2.1.2 Recycling

The aim of this stage is to separate the waste into two principal waste flows: wet (organic) and dry. The wet flow is taken to the organic treatment area. The dry fraction undergoes further sorting processes (optic, manual and magnetic) designed to recover the highest amount of recyclable materials.

### **2.1.3 Organic treatment**

During organic treatment, the biodegradable fraction of the MSW is processed by means of an anaerobic digestion process, which results in the maturation of the dehydrated digestate into a clean marketable compost. The volatile biodegradable fraction is fed into the digester reactors, where it remains for 21 days. Biogas is produced in this module and the digestate is dewatered. Part of the liquid is sent back to the bioreactors and the rest to the water treatment installation for purification.

The dewatered digestate (solid material) can be composted in windrows. Since this material is highly concentrated, it is necessary to mix it with woody green waste and to turn it periodically until organic fraction stabilization and sterilization are achieved.

### **2.1.4 Thermal treatment**

The remaining residue of the dry fraction is a combustible material that cannot be recycled. This waste fraction is sent to the advanced thermal recycling, means waste-to-energy installation. The steam produced in the boilers is sent to the turbine-generator to produce electricity.

After incineration process all inherent inert materials become a part of the bottom ash which, after being classified and matured, will be marketed as construction, fill or road base material, thereby reducing once again, the amount of residue to be disposed of the landfill.

### **2.1.5 Landfill**

The non- marketable bottom ash and the residual fraction of the gas cleaning by-products will be kept separate and will require disposal at a landfill.

### **2.1.6 Water and air control**

In order to accomplish an overall control of all air and water emissions both wastewater and odour-treatment systems are an integrated part off the IWMC. The wastewater treatment plant receives and treats the entire facilities contaminated water and returns clean water the various modules that require process water.

## **2.2 Example: Amtfors / Sweden**

The plant is designed for the combustion of MSW, containing about 20-35 wt% moisture. With waste from Norwegian and Swedish origin, the composition is rather similar to the European average with an LHV between 8 – 14 MJ/kg. A limited amount of waste (max.15%) can be replaced in the future by demolition wood. As the pulp for the paper



production in the paper factory is supplied from elsewhere, no pulp waste rejects will be added to the waste.

The main purpose of the WtE-CHP is the supply of process steam 6 bar. A flow of about 23 tons per hour must keep up the normal production of two paper machines. A district heating system requires 0.6 – 2.5 MWth, depending on the season of the year, with exceptional peak demands up to 4 MWth. A few smaller consumers are also tied into the steam cycle but as they consume negligible amounts of energy they are further not being discussed. Under nominal (average) plant operation the superheated steam from the boiler (40 barg, 380°C) is fed into the HP-stage of the turbine, where it is expanded to a pressure of 6 barg. About 2/3rd of the total steam flow is exported to the paper mills, while the remaining 1/3rd continues its expansion through the LP-stage of the turbine down to a backpressure of 1.2 bara. A water-cooled condenser releases the heat into the district heating at 90°C. When normal heat supply to the district heating is required (2.5 MWth or less) this temperature is adequate. However, in winter times when the heat demand can peak up to 4 MWth, supply at an elevated temperature of 120°C is required. In these cases steam at 217°C is taken from the 6 barg steam header to heat up the water from the DH in a separate heat exchanger.

WtE-boilers are inherently slow reacting steam generators with a typical range for thermal 'tuning' between 70 and 100% (excl. auxiliary fuel). However, sudden fluctuations in steam demand of +/- 50% are common for the paper factory. Measures for securing steam flow under these conditions are thus absolutely required. An accumulator allows storage of steam when more steam/heat is produced by the WtE-boilers than consumed, whereas the back-up boiler is used in those situations when demand rises more than production with the steam accumulator depleted.

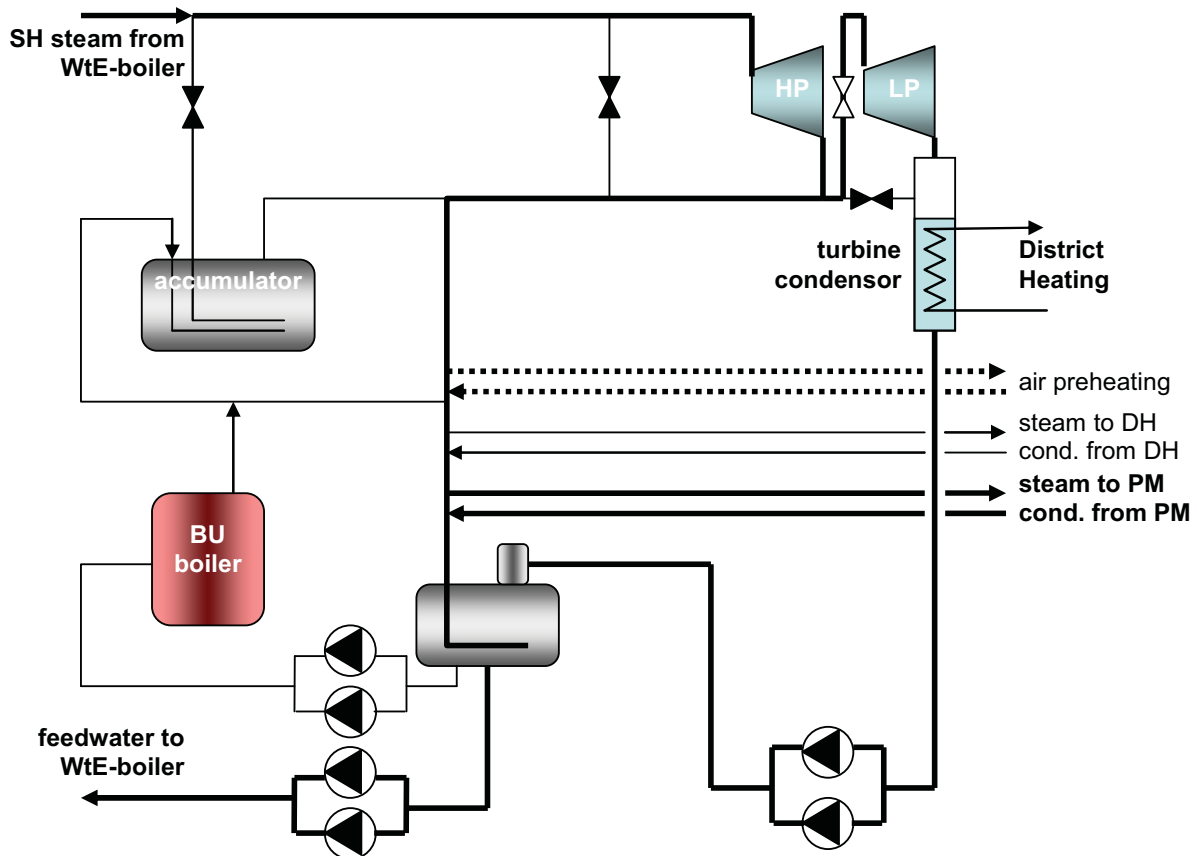

Figure 2 Steam cycle of the Åmotfors WtE-CHP including steam accumulation and back-up capacity.

### 2.3 Example: GMWA Runcorn / GB

The double full dry system turned out to be advantageous in NPV over other types of systems considered (s.a. bicarbonate, combination of SW+single dry), mainly due to the heat recovery 'bonus' associated with 145°C flue gas temperature at the boiler exit and the avoidance of remote boiler parts. The operation philosophy of the system copes with the knowledge that lime in dry conditions is slower reacting towards SO<sub>2</sub> in the flue gas than in moisturized conditions. The first stage (= reactor & bagfilter 1) takes the 'average' load of HCl and SO<sub>2</sub>, whereas the second stage (= reactor & bagfilter 2) is used as a 'police filter' to capture peaks in pollutants.

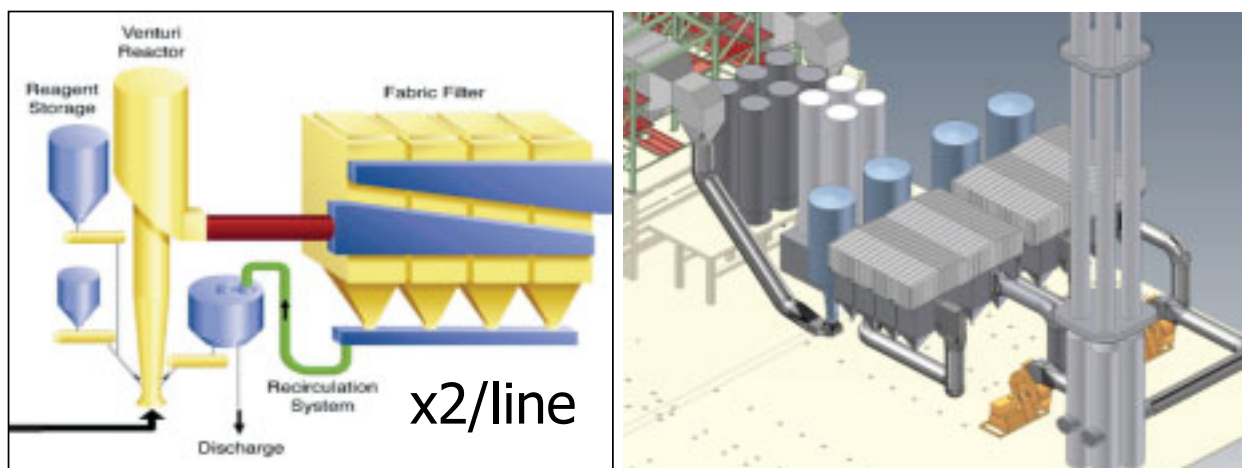

Figure 3 Keppel Seghers Double-dry FGC system with integrated lime buffer and recirculation system (a) principle, (b) as designed for GMW.

The integrated and recycling lime buffer allows for a robust and autonomous operation of the FGC-systems, using a reagent that is well-available on the market and results in well-accepted residues for disposal. And through the absence of water, related operational problems i.e. clogging, screw blocking, corroding residues at low temperature are being avoided. In the context of a CHP-application on one of England's largest industrial chemical sites, the Keppel Seghers double dry system contributes in this way to a maximally secured energy supply.

In Figure 4 a relative financial comparison between basic FGC-types is presented (selected). All FGC configurations considered are capable of treating flue gas with a high Cl/S-ratio. The combination of a semi-wet lime reactor with a single dry lime stage is thereby taken as reference for comparison. Investment costs are considered as 'single shot' and also include for differences in boiler surface and eventual other process equipment for each respective case. Maintenance and (net) operation costs are accumulated values over 15 years and reflect a.o. the expenses for chemicals, utilities, filter sleeves and disposal costs (UK market). Sales bonuses from steam & electricity are deducted from the operation costs for each scenario accordingly. Although financial incentives are set in place in the UK for optimizing the energetic output of WtE-plants, these benefits are not encalculated.

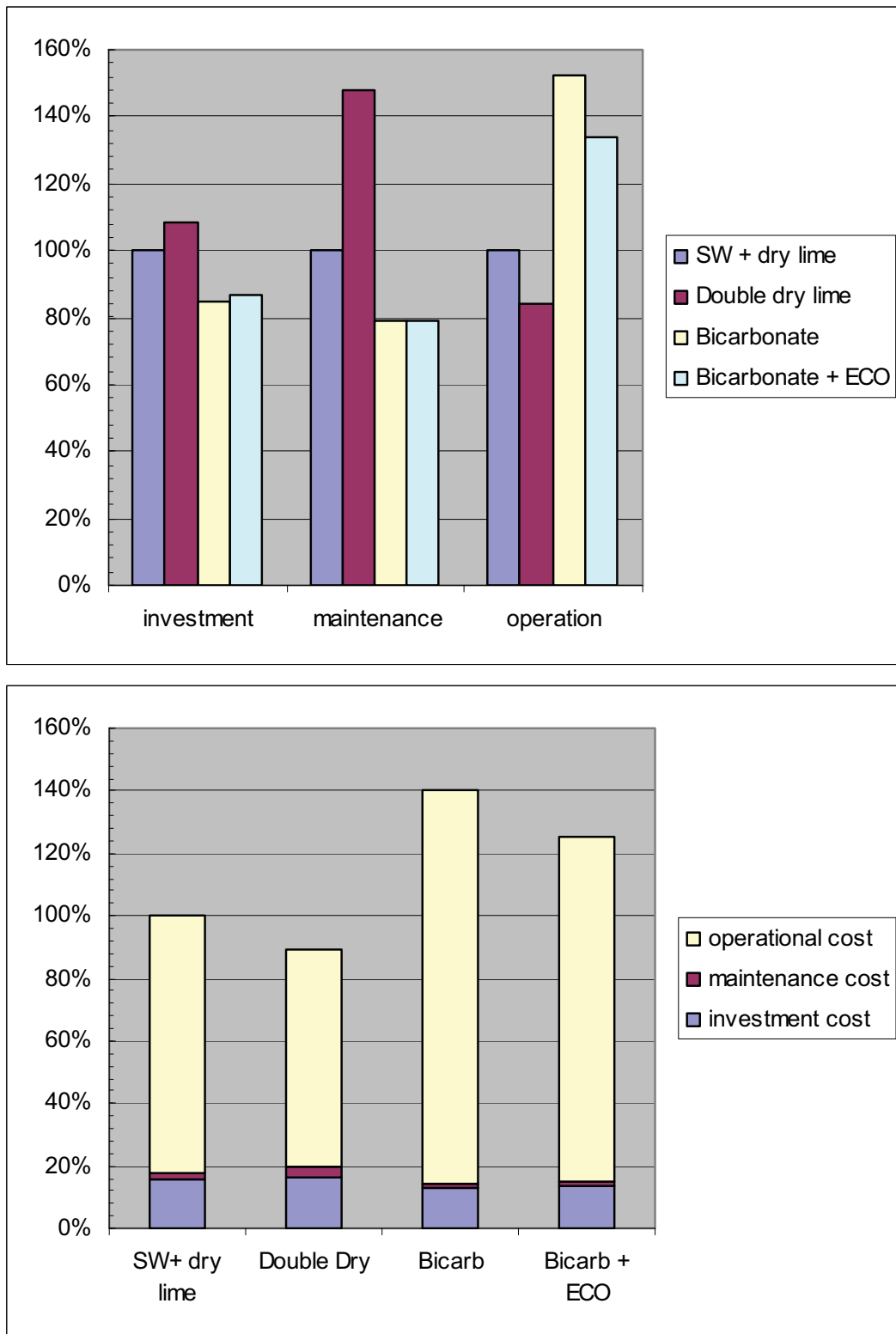

Figure 4 Financial comparison of 4 selected cases over a time of 15 years: 1) semi-wet + dry lime, 2) double dry lime, 3) bicarbonate and 4) bicarbonate with external economizer before stack. Although the investment and the maintenance (= filter sleeves) costs are relatively higher for a double dry system (a), the low operational expenses turn the overall cost picture in favor of the double dry lime system (b). The combination of lime as reagent and the energy bonus at a flue gas temperature of 145°C offers a sound investment perspective.

### 3 Conclusion

The path is characterized by the fact that it is went. There is no golden rule on the way to better efficiency of waste-to-energy plants. Only the combination of many little pieces can contribute to a better result and satisfied customers, politicians and in the end our environment. We are still improving and working on better concepts to live up to this challenge and are happy, that the public acceptance of waste-to-energy plants is improving every year.

### 4 Literature

- |  |      |   |
|--|------|---|
| Marc Van Craen,<br>Karel Van Velthoven           | 2007 | Integrated waste management, Waste Management World, November-December 2007   |
| Dr.ir. Johan De Greef,<br>Dr.ir. Kenneth Villani | 2010 | Double Dry Lime-based FGC: combining gas cleaning performance with increased energetic efficiency & availability; 7. Potsdamer Fachtagung; 25.-26. Februar 2010 |
| Dr.ir. Johan De Greef<br>Dipl.-Ing. Stefan Kipp  | 2010 | Flexible Abfall- und EBS- Verbrennungsanlagen mit Kraft-Wärme-Kopplung an Industriestandorten; Energie aus Abfall Band 7, TK Verlag                             |

#### Author's Address:

Dipl.-Ing. Mariusz Maciejewski  
Keppel Seghers GmbH  
Am Wasserturm 4  
D- 40668 Meerbusch  
Telefon +49 2150 70904 129  
Email: [mariusz\\_maciejewski@keppelseghers.com](mailto:mariusz_maciejewski@keppelseghers.com)  
Website: [www.keppelseghers.com](http://www.keppelseghers.com)

# Erzielung einer hohen Energieeffizienz im EBS-Kraftwerk Stavenhagen

K.-H. Plepla, Th. Hegner

Nehlsen Heizkraftwerke GmbH & Co. KG, Stavenhagen, Deutschland

## Achieving a high energy efficiency at the EBS power plant Stavenhagen

### Inhaltsangabe

Mit der Errichtung des Ersatzbrennstoff-Heizkraftwerkes Stavenhagen durch den Contractor Nehlsen konnte die Versorgung des Kartoffelprodukte-Herstellers Pfanni mit Prozeßdampf und Strom von fossilem Primärenergieeinsatz auf Brennstoff aus der mechanisch-biologischen Müllaufbereitung umgestellt werden. Die aus der Neuorientierung der Energiebereitstellung resultierenden Vorteile sind sowohl eine Schonung der fossilen Energieressourcen als auch eine konsequente Ergänzung der Kreislaufwirtschaft für Abfall mit energetischer Nutzung, der Umsetzung der Vorgaben für die Deponierung von Reststoffen, eine Sicherung vorhandener Arbeitsplätze in der Lebensmittel- und Zulieferindustrie einschließlich einer Generierung neuer Arbeitsplätze im Heizkraftwerk. Nicht zuletzt stellt die gekoppelte Erzeugung von Prozeßdampf und Strom mit Einsatz von MBA-Brennstoff eine preiswerte Beschaffungsalternative für Energie bei Pfanni dar.

## 1 Allgemeiner Aufbau des EBS-HKW Stavenhagen

Betreiber des EBS HKW Stavenhagen ist die Nehlsen Heizkraftwerke GmbH & Co. KG. Das EBS HKW versorgt seit Sommer 2007 den Kartoffelprodukte-Hersteller Pfanni in Kraft-Wärme-Kopplung mit Prozessdampf und Strom. Energielieferant und Abnehmer liegen lokal eng beieinander. Vom Pfanni-Werk Stavenhagen und vom EBS HKW nicht benötigte elektrische Energie wird in ein externes Netz eingespeist.

Bild 1 zeigt die unmittelbar benachbarten Standorte Pfanni und Nehlsen.



Abbildung 1: Standorte Pfanni und Nehlsen

Das erste Projekt zum Energiecontracting bei Nehlsen entwickelte sich aus Überlegungen des Kartoffelprodukte-Herstellers Pfanni in Stavenhagen, die Energiebeschaffung neu zu strukturieren.

Auf Grund steigender Preise für Erdgas und Strom sowie der Möglichkeit, Prozeßdampf und Elektrizität lokal in Kraft-Wärme-Kopplung erzeugen zu können, entstand der Gedanke, das vorhandene erdgasbefeuerte Heizwerk durch ein mit Ersatzbrennstoffen befeuertes Heizkraftwerk abzulösen.

Die ersten Planungen gingen von einem Bedarf an Ersatzbrennstoff in einer Größenordnung von 90.000 t/a aus. Mit dem Einsatz von regional verfügbarem Brennstoff aus Müll konnte der Gedanke der Kreislaufwirtschaft sowohl im Sinne stofflicher als auch unter dem Aspekt der energetischen Verwertung umgesetzt werden.

Grundvoraussetzung für die Entscheidung zum Bau der Anlage im Mai 2005 war, dass das Heizkraftwerk zum 01.08.2007 gesichert Prozessdampf und Strom an Pfanni liefern wird.

Zum Betrieb der Neuanlage wurde ein Personalmehrbedarf von 15 Mitarbeitern gegenüber der vorhandenen Prozessdampferzeugung auf Basis Erdgas ermittelt. Die Schaffung neuer Arbeitsplätze in einer strukturschwachen Region in Mecklenburg-Vorpommern fand auch positive Resonanz bei den Vertretern der lokalen Politik.

Das Projekt Heizkraftwerk Stavenhagen zur Versorgung von Pfanni mit Prozessdampf und Strom fand große Beachtung im Unilever-Konzern, da durch die neue Art der Energiebereitstellung die Beschaffungskosten für Dampf und Strom wesentlich reduziert werden konnten. Dies verdeutlichte sich vor allem vor dem Hintergrund der stetig steigenden Preise für Erdgas, das Pfanni in einem Umfang von 14 Mio. m<sup>3</sup>/a zur Verarbeitung von 160.000 t/a an Kartoffeln beziehen musste.

Mit der Neugestaltung der Energieversorgung einher ging eine Erweiterung der Pfanni-Produktionsanlagen am Standort Stavenhagen, die sowohl eine Standortsicherung für Pfanni als auch eine Neubewertung der Durchsatzmenge der Ersatzbrennstoffe bedeutete. Somit ging die Planung für den Brennstoffbedarf von 95.000 t/a bei einem unteren Heizwert von 14,2 MJ/kg aus.

Bild 2 zeigt die Energieströme zwischen Heizkraftwerk und Pfanni sowie den benötigten Bedarf an Ersatzbrennstoff.





Abbildung 2: Energieströme zwischen HKW und Pfanni

Der im Heizkraftwerk erzeugte Frischdampf nach Kessel liegt mit 400°C/42 bar an und wird zur Entnahme-Kondensations-Turbine geführt. Vor Turbine wird ein Teilstrom als Prozessdampf für Pfanni zur Herstellung von Dampf für die Lebensmittelproduktion mit 16 bar entnommen. Die Wärmeübertragung erfolgt in Reindampferzeugern, die sekundärseitig mit zur Lebensmittelproduktion zugelassenem Speisewasser beaufschlagt werden. Der Primärkreislauf zwischen Heizkraftwerk und Reindampferzeuger ist ein geschlossener Dampf-/Kondensat-Kreislauf. Sekundärseitig wird der erzeugte Dampf zur automatisierten Schälung von Kartoffeln sowie zu indirekten Trocknungsprozessen verwendet.

Über eine 16-bar-Entnahme an der Turbine wird ein zweiter Prozessdampfstrom ausgekoppelt, der über weitere Reindampferzeuger zur Herstellung von sekundärseitigem 11-bar-Dampf in Lebensmittelqualität für Koch- und Trocknungsprozesse genutzt wird. Primärseitig ist der Dampf-Kondensat-Kreislauf für den Entnahmedampf ebenfalls als geschlossenes System konzipiert.

Die Verschaltung der Dampfströme zwischen Heizkraftwerk und Pfanni zeigt Bild 3.

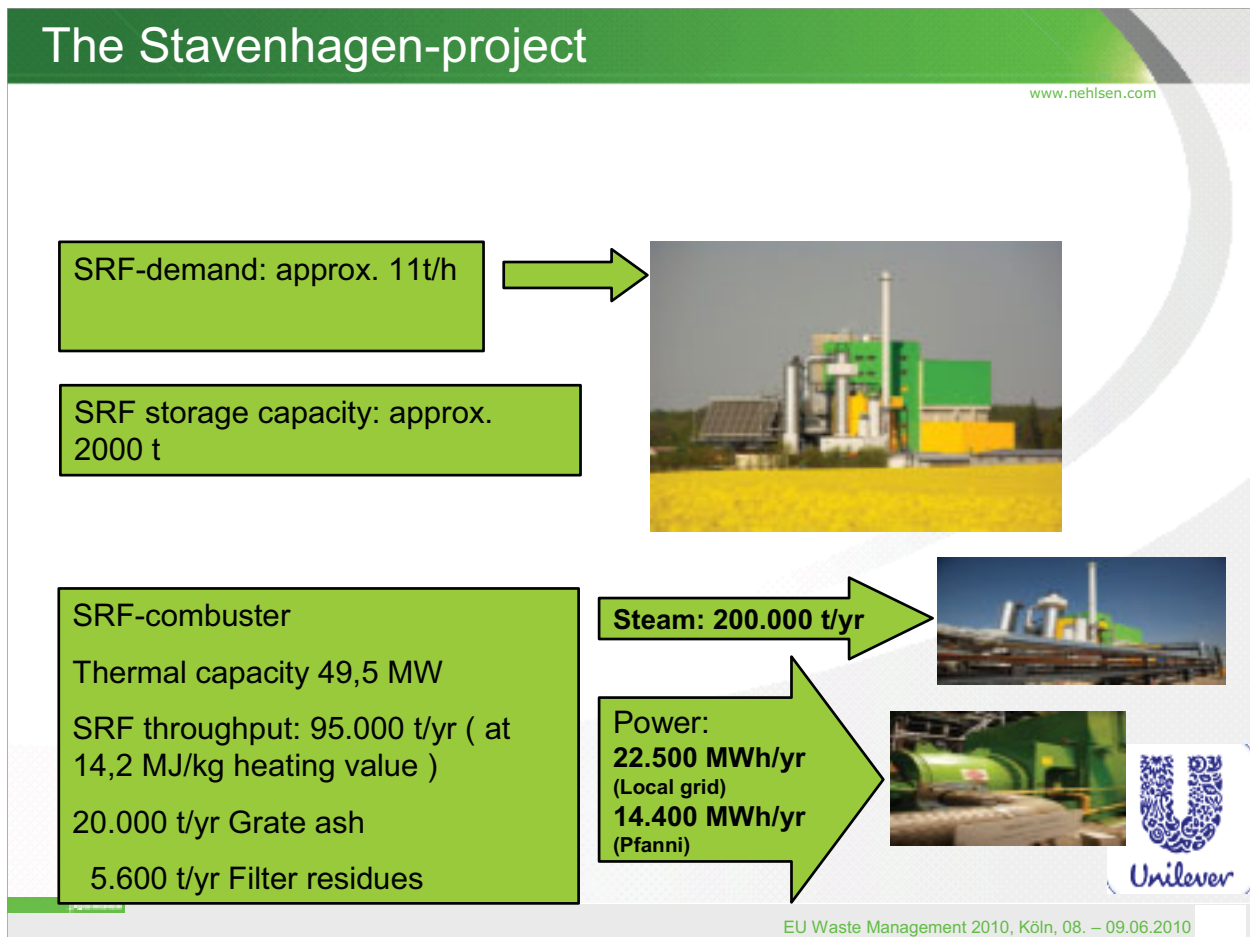

Abbildung 3: Verschaltung Dampfströme

Als Haupt-Brenstofflieferanten wurden zwei Gesellschaften gebunden, die in Mecklenburg-Vorpommern Anlagen zur Erzeugung von Ersatzbrennstoffen betreiben. Annähernd zwei Drittel des Brennstoffbedarfs werden in unmittelbarer Nähe zum Heizkraftwerk produziert. Sowohl der kurze Transportweg als auch die Möglichkeit zur wirtschaftlichen Zwischenlagerung des Brennstoffes bei Stillstandszeiten des Heizkraftwerkes bieten eine große Flexibilität der Versorgung. Zudem wird der größte Teil der zur Brennstoffherstellung erforderlichen Reststoffmengen aus den angrenzenden Landkreisen gesammelt, so dass auch die erforderliche Logistik wirtschaftlich gestaltet werden kann.

Herkunft des Brennstoffs sowie Einzugsgebiet des Brennstoffaufkommens zeigt Bild 4.

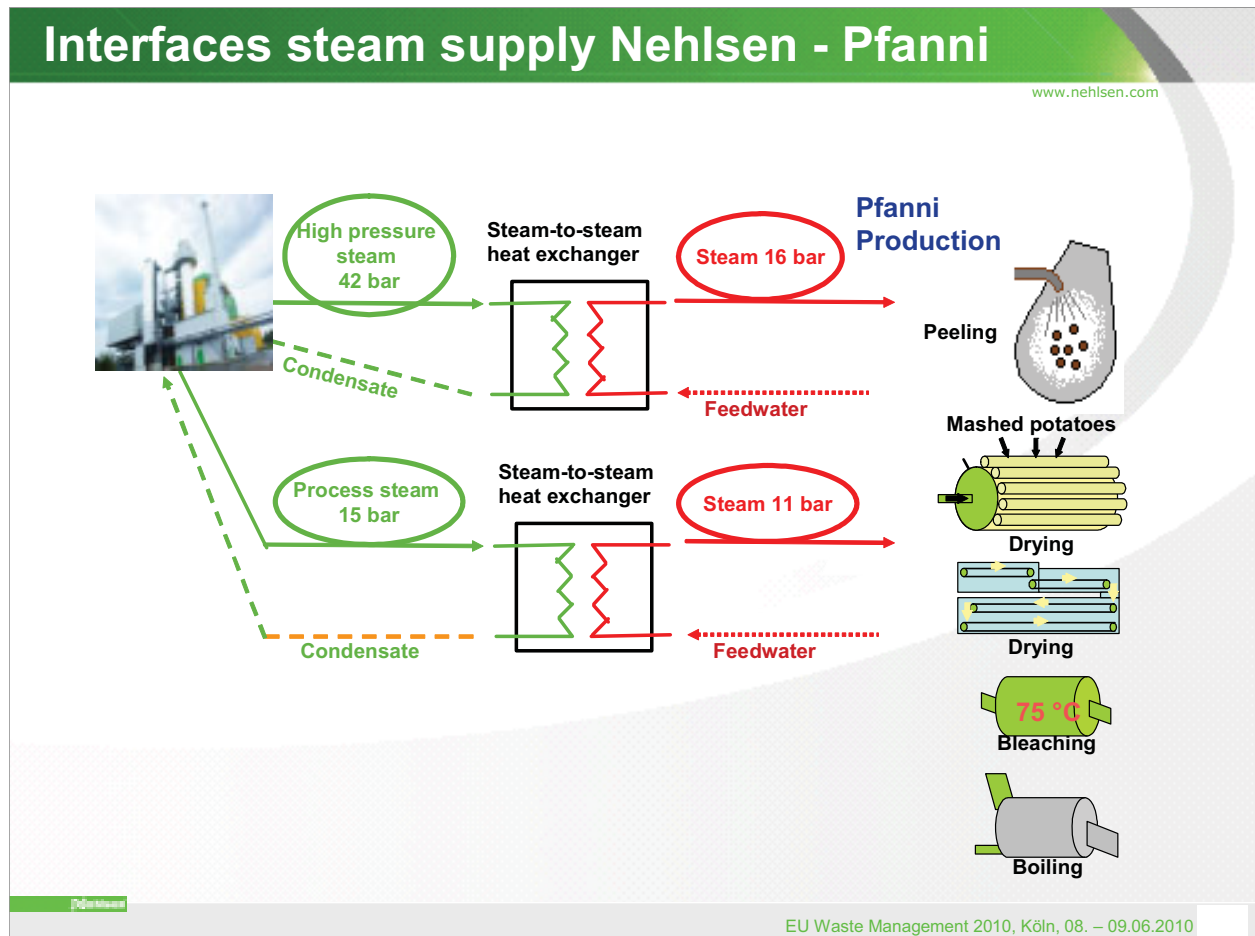

Abbildung 4: Herkunft des Brennstoffes sowie Einzugsgebiet

## 2 Feuerung und Kessel

Der Heizkraftwerksprozess geht von einer Anlieferung des Brennstoffs mit Muldenkippern, Absetzkippern und Walking-Floor-Fahrzeugen aus. Der Bunker fasst mit bis zu 2.000 t ausreichend Ersatzbrennstoff für vier Vollasttage.

Bild 5 zeigt das Feuerleistungsdiagramm für die Rostfeuerung, Bauart Thyssen-Krupp Xervon, die von Baumgarte Boiler Systems in Stavenhagen geliefert wurde. Die Feuerung ist ausgelegt für eine Kesselnennlast von 47,5 MW, mit Überlastbereich bis 49,5 MW. Die Varianz im Unteren Heizwert reicht von 11 MJ/kg bis 18 MJ/kg, bei einer fahrbaren Dampfleistung bis 54 t/h.

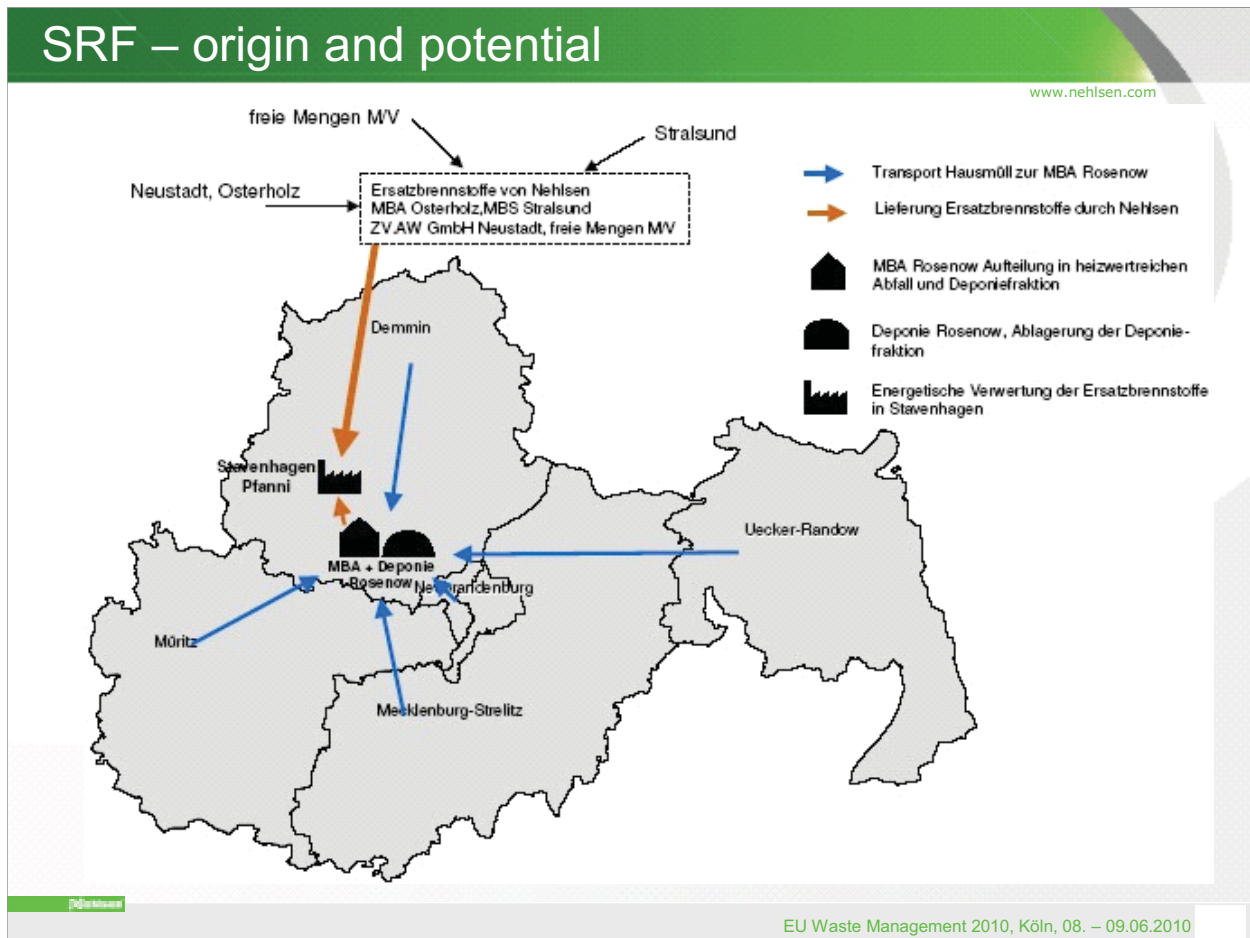
## Firing capacity diagram



Abbildung 5: Feuerleistungsdiagramm

Bild 6 zeigt die Auslegungsdaten des eingesetzten Brennstoffs. Die fahrbare Korngröße bei soliden Partikeln bis 25x5x2,5 cm und bei Folien bis 25x25 cm zeigt, dass für eine Rostfeuerung keine hochwertige Brennstoffzerkleinerung erforderlich ist, im Gegenteil ist die grobe Körnung sowohl für den mechanischen Transport mittels des EBS-Greifers als auch des Verbrennungsprozesses im Rostbett von Vorteil. Beim Brennstofflieferanten führt die grobe Körnung zu Einsparungen im apparativen und energetischen Aufwand bei der EBS-Herstellung.

Wasser- und Aschegehalt, jeweils begrenzt auf 25%, limitieren den Heizwert auf ca. 13 MJ/kg.

## SRF-specifications, I

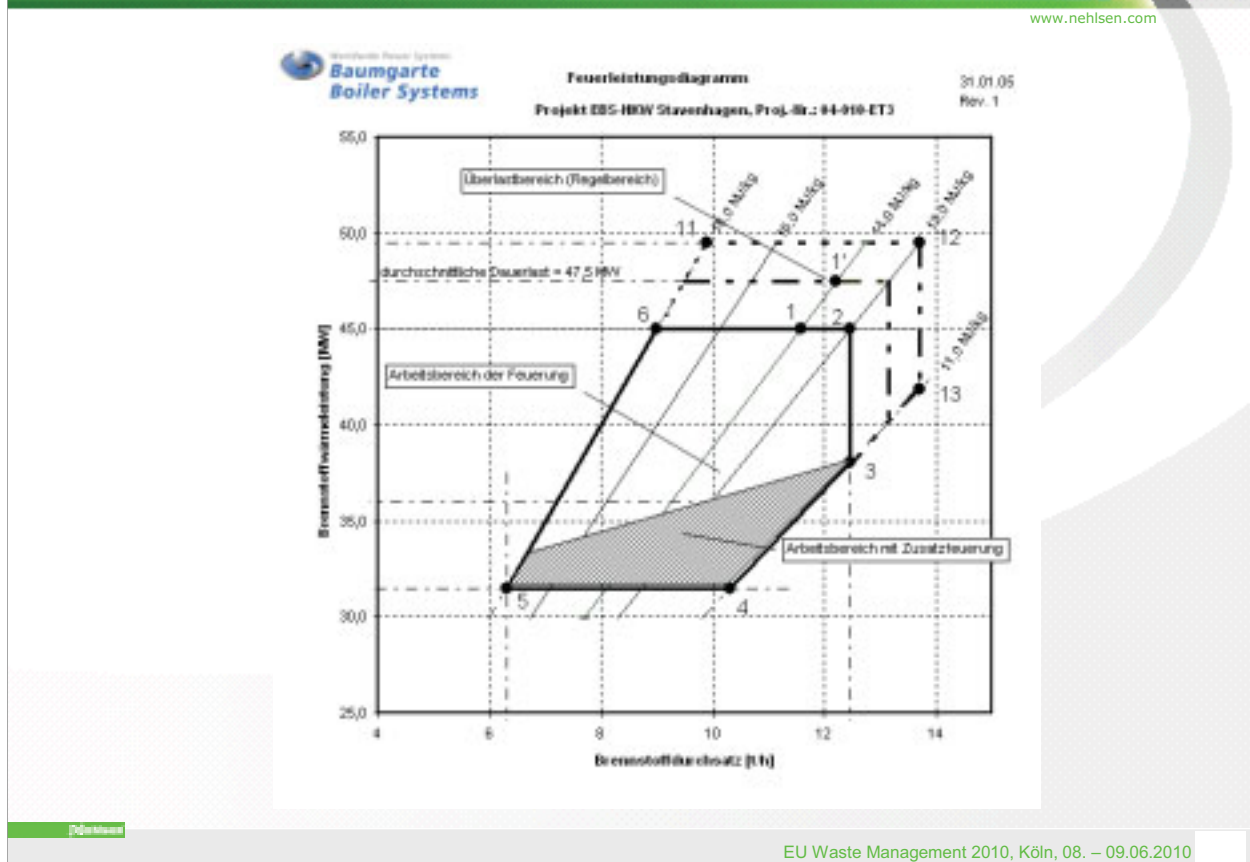
www.nehlsen.com

Bezeichnung	Einheit	Minimum	Maximum
<b>Physikalische Qualitätsmerkmale</b>			
Heizwert	MJ/kg	13	18
Stückigkeit L*B*H	mm		250*50*25
Folien L*B	mm		250*250
Störstoffe / Verunreinigungen	Keramik, Steine, Porzellan, Sand, Fe-Metalle, NE-Metalle		1%TM

NEHlsen

EU Waste Management 2010, Köln, 08. – 09.06.2010

## SRF-specifications, II

www.nehlsen.com

Komponente	Einheit	Mittel	Maximum
<b>Ballaststoffe</b>			
Wasser	%roh	20	25
Asche	% TS	20	25
<b>Qualitätsmerkmale Spurenelemente (Grenzwerte)</b>			
Schwefel (S)	% TS		1,0
Chlor (C)	% TS		1,5
Fluor (F)	mg/kg TS		400
Quecksilber (Hg)	mg/kg TS		3

NEHlsen

EU Waste Management 2010, Köln, 08. – 09.06.2010

Abbildung 6: Auslegungsdaten des eingesetzten Brennstoffes



Die maximal zulässigen Schwefel-, Chlor-, Fluor- und Quecksilberkonzentrationen im Brennstoff beeinflussen primär den Bereich Dampferzeuger und Rauchgasreinigung und weniger den Bereich Rostfeuerung.

Bild 7 zeigt die grundsätzliche Anordnung von Brennstoffzuführung, Rost und Entschlackung. Der Brennstoff wird mittels Schallengreifer aus dem EBS-Bunker dem Brennstofftrichter zugeführt. Zur Absicherung der Brennstoffvorlage im Trichter gegen Rückbrand bei leerem Brennstoffschacht ist eine hydraulische Brennstoffklappe zwischen Brennstofftrichter und Brennstoffschacht eingebaut.



Abbildung 7: grundsätzliche Anordnung von Brennstoffzuführung, Rost und Entschlackung

Der Brennstoffschacht unterhalb des Brennstofftrichters ist über dem hydraulisch angetriebenen Aufgabeschieber mit einer Wasserkammer umkleidet.

Der Rost besteht aus zwei Rostbahnen, jeweils 2375 mm breit und 9200 mm lang. Jede Bahn hat drei Rostzonen und fünf Luftzonen. Die beweglichen Rostreihen werden hydraulisch angetrieben, wobei die Hubgeschwindigkeit lastabhängig zwischen 5 – 10 mm/s variiert. Der maximale Hub beträgt 400 mm. Der Rostbelag ist wassergekühlt, die Zu- und Ableitung des Kühlwassers erfolgt über Schläuche im Bereich der Primärluftzuführung.

Die über das Kühlwassersystem den Roststäben entnommene Wärme wird mittels eines Luftvorwärmers wiederum der Primärluft zugeführt. Bei einer Wärmefreisetzung von 15 – 25 kW/m<sup>2</sup> lassen sich Kühlwassertemperaturen von ca. 80°C als Vorlauf zum Pri-

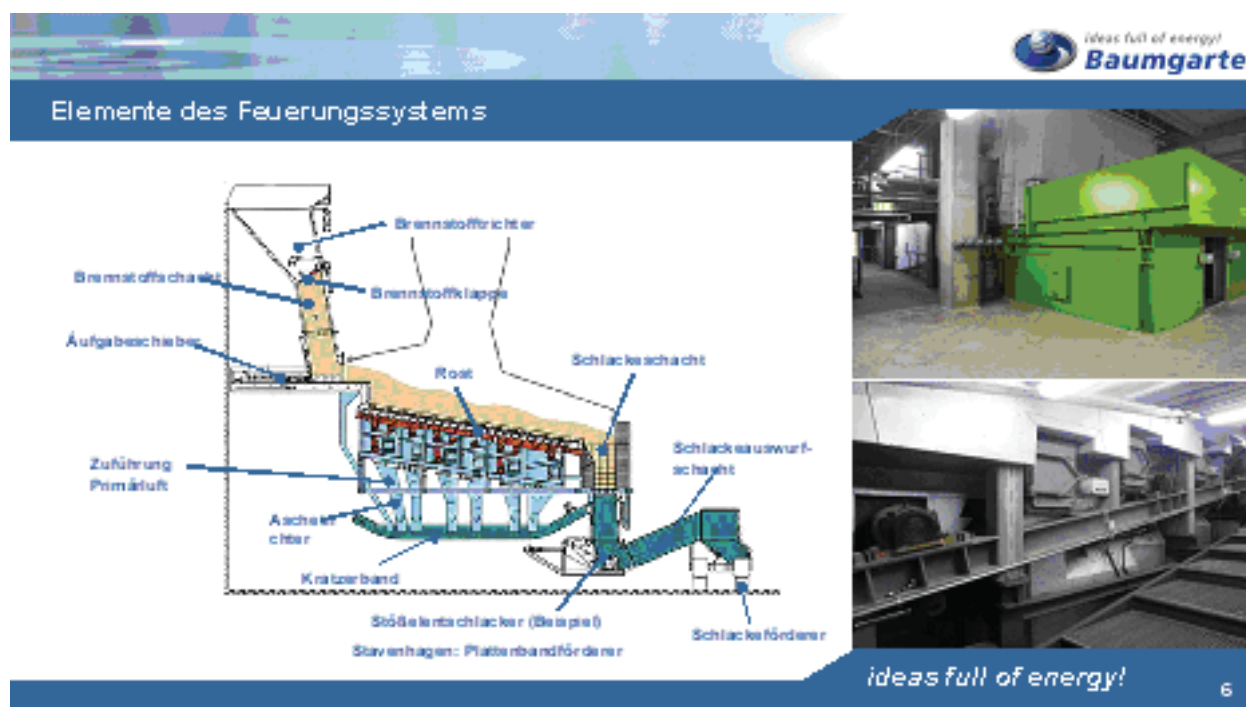
märluftluvo erreichen. Zur Regelung der Primärluftvorwärmung kann zusätzlich ein Teil der Wärme über einen Dachkühler abgeführt werden.

Das Kühlsystem ist entsprechend Bild 8 als geschlossenes System ausgeführt. Somit ist eine Kontrolle der Dichtheit des Systems im Betrieb sehr einfach zu realisieren.



Abbildung 8: Kühlsystem

Die Verteilung der Verbrennungsluft auf Primär- und Sekundärluft zeigt Bild 9. Der Anteil Primär- / Sekundärluft ist abhängig vom Brennstoff variabel zwischen 50% und 70%. Dies gilt ebenso für die Aufteilung der Primärluftmengenanteile auf die einzelnen Rostzonen.



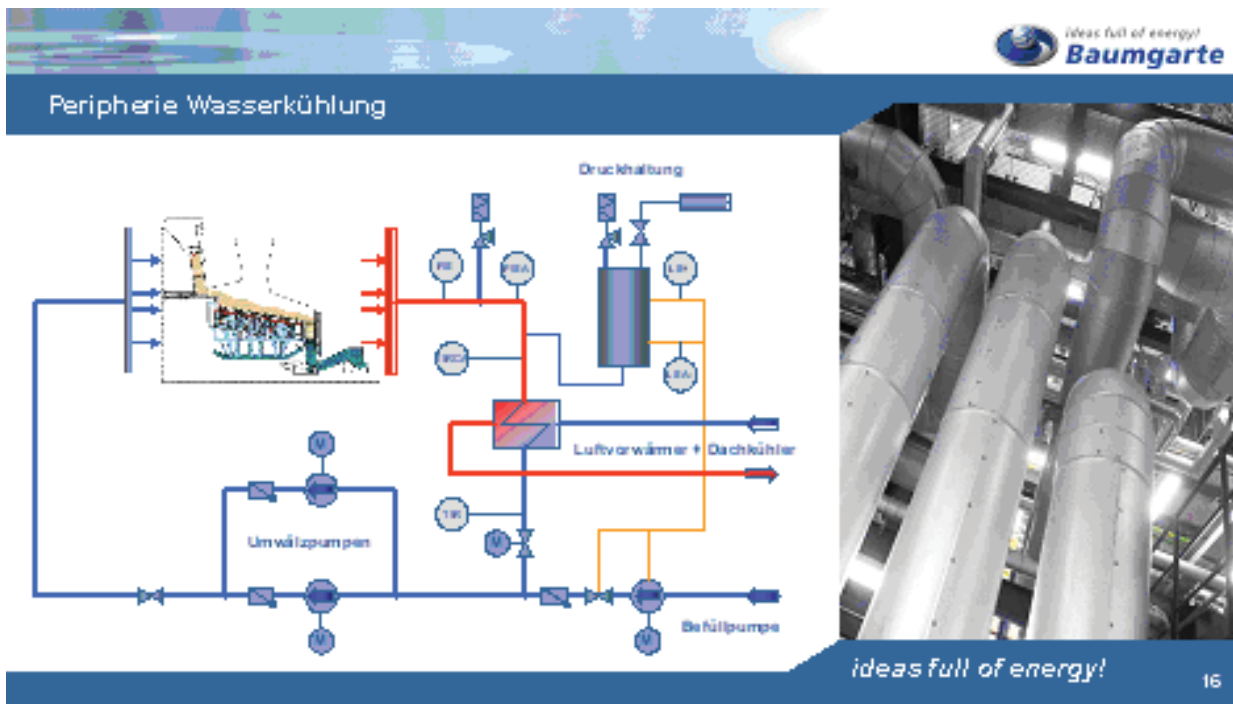

Abbildung 9: Verteilung der Verbrennungsluft

Der Gesamtaufbau des EBS-HKW ist schematisch in Bild 10 dargestellt.

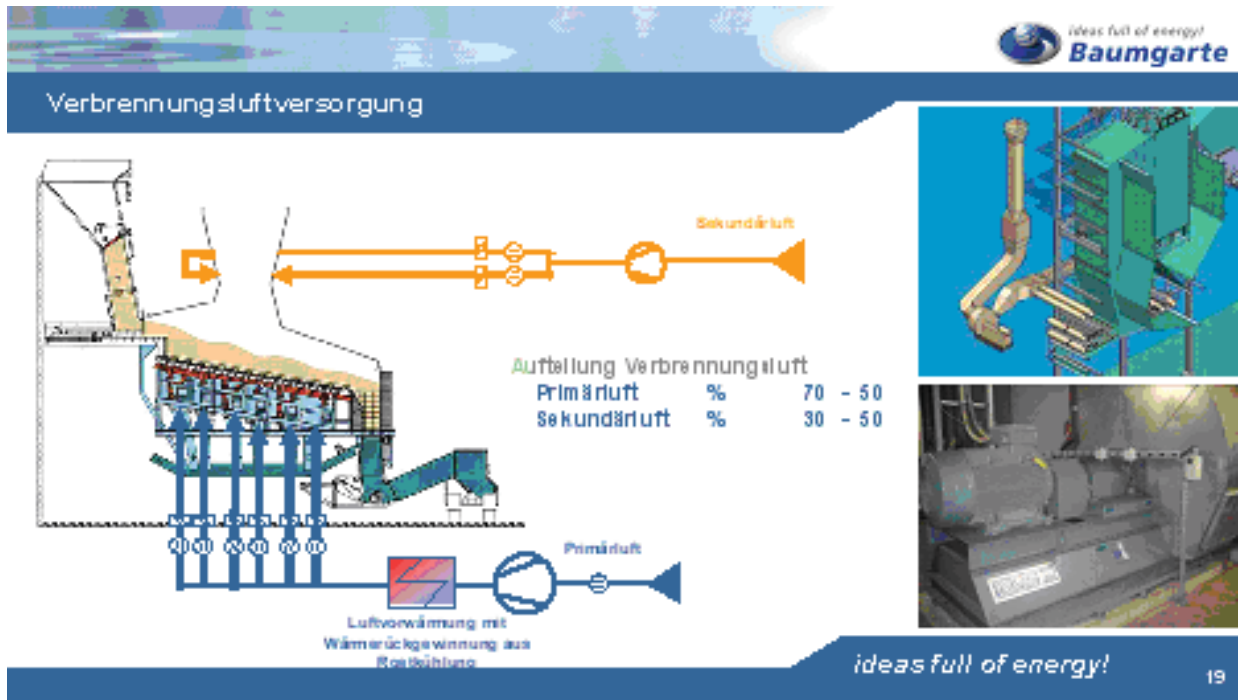

Abbildung 10: Aufbau EBS-HKW

Der erste Zug des Dampferzeugers ist mit Stampfmasse ausgekleidet bzw. im oberen Bereich gecladdet. Erster, zweiter und dritter Zug sind als Vertikalzüge ohne Berührungsheizflächen ausgeführt, während der vierte Zug als Horizontalzug (Tail-End) die senkrecht angeordneten Berührungsheizflächen enthält. Zur Abreinigung wird ein mechanisch betriebenes Hammerwerk eingesetzt. Die Rauchgase gelangen nach Kesselende zu einem Sprühabsorber mit nachgeschaltetem Reaktionsturm. Die Rauchgasreinigung erfolgt mit Kalkhydrat und Herdofenkoks über ein halbtrockenes Verfahren. Der Aufbau der Rauchgasreinigung ist in Bild 11 dargestellt.

## Schema Rauchgasreinigung

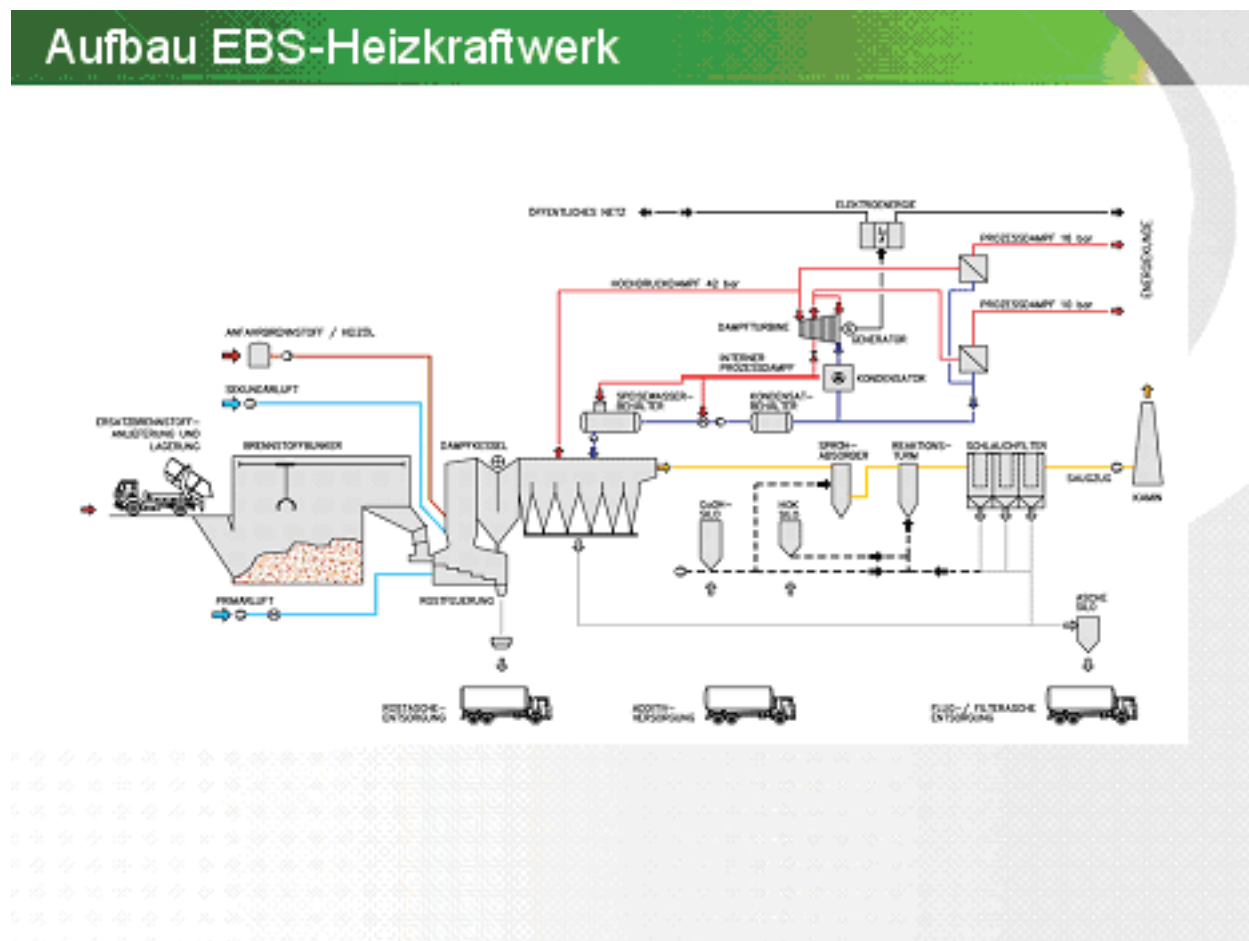

Abbildung 11: Aufbau der Rauchgasreinigung

Zur Rauchgasreinigung wurde das Kugelrotor-Umlaufverfahren installiert, ausgeführt als Kombination Sprühabsorption – Partikelkonditionierung. Das Verfahren bietet eine hohe Abscheideleistung in Verbindung mit niedrigen Gesamtkosten. Die nach 17. BImSchV geforderten Grenzwerte können, auch bei Schadgasspitzen, gesichert eingehalten werden.

Die erste Stufe des Kombinationsverfahrens bildet der Sprühabsorber. Seine Aufgaben sind die Gaskonditionierung zur Einstellung der optimalen Reaktionstemperatur und Anhebung der relativen und absoluten Feuchte sowie die Vorsorption durch Zugabe von

Kalkmilch. Die Kalkmilchzugabe gewährleistet gleichzeitig eine Absenkung des Säuretaupunktes zur Vermeidung von Korrosionen.

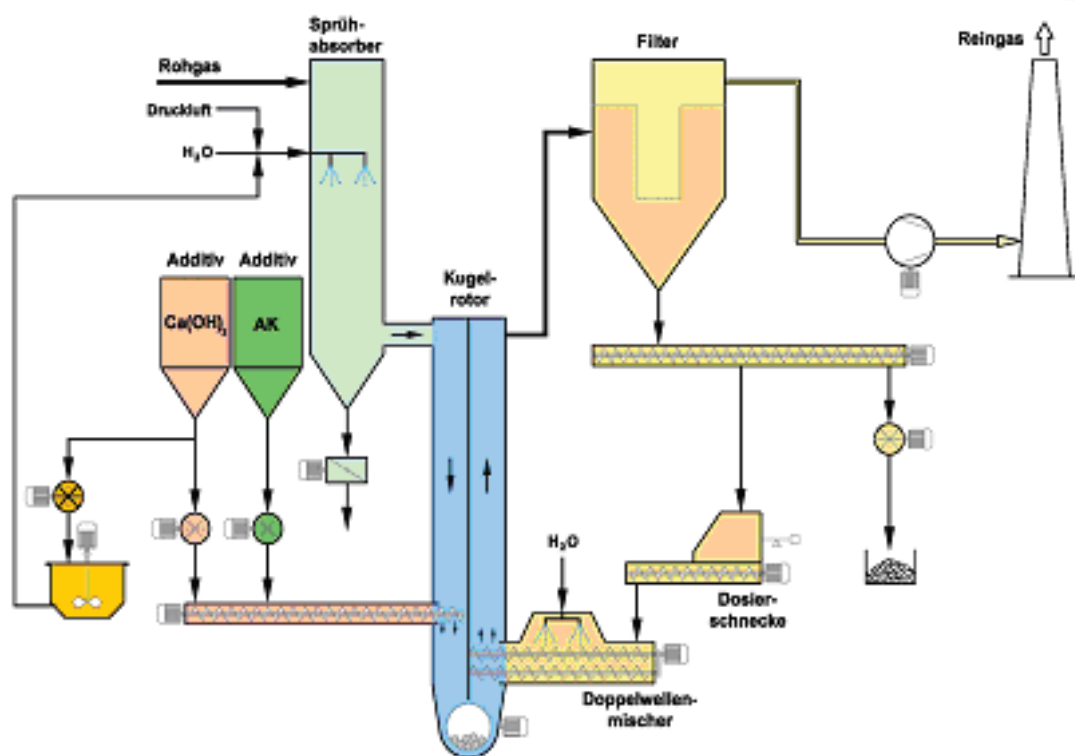
Da insbesondere bei EBS-Verbrennungen häufig die Gasfeuchte bedingt durch die Zusammensetzung des Brennstoffes gegenüber zum Beispiel Hausmüllverbrennungen niedriger ist, kommt der separaten Einstellmöglichkeit der optimalen Gastemperatur besondere Bedeutung zu.

Die im Wesentlichen zur Schadgassorption genutzte zweite Abscheidestufe bildet die Reaktor-Filterkombination (Kugelrotor – Umlaufverfahren) mit  $\text{Ca}(\text{OH})_2$ -Zugabe und vielfacher Partikelrückführung einschließlich Konditionierung der Rückführpartikel.

$\text{Ca}(\text{OH})_2$  und Aktivkoks werden gewichtskontrolliert in den Eintrittsschacht des Umlenkreaktors vor filterndem Abscheider aufgegeben.

Der filternde Abscheider ist als Sechs-Kammerfilter konzipiert und mit vertikal angeordneten Flachschräuchen ausgestattet. Die Abreinigung der Filterschräuche erfolgt on line im Puls-Jet-Verfahren. Als Filtermaterial wird ein Nadelfilz der Qualität 100% PTFE verwendet. Das gereinigte Rauchgas wird über den Saugzug dem Schornstein zugeführt.

Die Kapazität des Reststoffsilos ist ausreichend für mindestens vier Vollasttage. Die Entsorgung erfolgt über Silofahrzeuge. Die Jahresmenge an Filterreststoff beträgt ca. 5.600 t.

Die am Rostende anfallende Rostschlacke wird in zwei Nassentschlackern abgekühlt und dann mechanisch über Band dem Schlackebunker zugeführt. Die Entsorgung erfolgt über Kippfahrzeuge. Die Jahresmenge an Rostschlacke beträgt ca. 20.000 t.

### **3 Turbogeneratorsatz und Luftkondensator**

Der im Kessel erzeugte Hochdruckdampf wird einer Entnahme-Kondensations-Turbine zugeführt. Die Turbine hat einen Entnahmestutzen (16 bar (ü)) für die Bereitstellung des Produktionsdampfes für das Pfanni-Werk und eine Anzapfung (3 bar (ü)) für die Hilfsdampfbereitstellung des EBS HKW.

Der Abdampf der Niederdruckstufe wird in einer Luftkondensatoranlage kondensiert. Je nach Dampfabnahme durch Pfanni variiert die Stromerzeugung des Turbogeneratorsatzes. Bei maximaler Entnahme werden ca. 4,8 MW el erzeugt, im Kondensationsfall (keine Dampfabnahme durch Pfanni) bis 9,6 MW el.

Das Kondensat aus dem Wasser-Dampf-Kreis des HKW, im Wesentlichen bestehend aus den Kondensaten des Luftkondensators und der Dampf-Dampf-Wärmetauscher an der Schnittstelle zum Produktionsdampfsystem von Pfanni, wird nahezu vollständig

wieder dem Speisewasser des Dampferzeugers zugeführt. Das erforderliche Nachspeisewasser für den Hochdruckdampfkreis wird über eine Umkehrosmose-Anlage hergestellt und thermisch entgast.

## **4 Energieeffizienz**

Durch die Auskopplung von Prozeßdampf für Pfanni in einer Größenordnung von 130 GWh/a als 40-bar-Dampf und 16-bar-Dampf, wird ein Anteil von 34 % der eingesetzten Primärenergie aus EBS sowie des An- und Abfahrbrennstoffs, Heizöl EL, direkt als thermische Energie zur Versorgung der Produktionsprozesse bei Pfanni verwendet. Nur 1,3 % der jährlich benötigten Primärenergie muss als Heizöl zugeführt werden. Auch bei Unteren Heizwerten um 11 MJ/kg ist ein stabiler Verbrennungsprozeß ohne Stützfeuer möglich, der die Feuerraumtemperatur gesichert auf einem Niveau von 950°C – 1000°C und somit ausreichend oberhalb der nach 17. BImSchV geforderten Temperatur von 850°C hält.

Die über den Turbosatz gewonnene elektrische Arbeit liegt bei 49,3 GWh/a, brutto. Auslegungsgemäß liegt der Eigenbedarf des HKW bei 12,4 GWh/a, Betriebserfahrungen zeigen, dass der reale Eigenbedarf nur etwa 80% des Planwerts beträgt.

Unter Anwendung der Energieeffizienzformel nach Annex II ergibt sich somit gemäß Bild 12 für das EBS-HKW Stavenhagen ein Energieeffizienzfaktor von 0,72, was eine Übererfüllung der Anforderungen für Neuanlagen in Höhe von ca. 10% bedeutet.



Abbildung 12 Energieströme

Die Brennstoffausnutzung über das Heizkraftwerk wirkt, in Relation zur ursprünglichen Energiebeschaffungssituation bei Pfanni, CO<sub>2</sub>-mindernd. Im Vergleich zur getrennten Erzeugung von Prozessdampf aus Erdgas und Strom nach deutschem Kraftwerksmix sowie der EBS-Verbrennung über eine MVA ergibt sich eine Einsparung an CO<sub>2</sub> in einer Größenordnung von über 10.000 t/a.

Der ökologische Vorteil der Versorger-/ Energieerzeuger-/ Energienutzer-Konstellation am Standort Stavenhagen zeigt sich über die Energieeffizienzfaktor-Bewertung hinaus zusätzlich in der Tatsache, dass der zur Herstellung der erforderlichen EBS-Qualitäten geringe Energieeinsatz sowie die wegen der räumlichen Nähe der Brennstoffhersteller zum HKW-Standort niedrige Transportenergie in der Gesamtbilanz noch nicht berücksichtigt sind.

Optimierungspotentiale für weitere Verbesserungen der Ökobilanz liegen in einer Steigerung der lokalen Verwertung des erzeugten Überschuss-Stroms, der Verknüpfung der Energiewandlungsprozesse am HKW-Standort u. a auch mit dem kommunalen Fernwärmesystem.

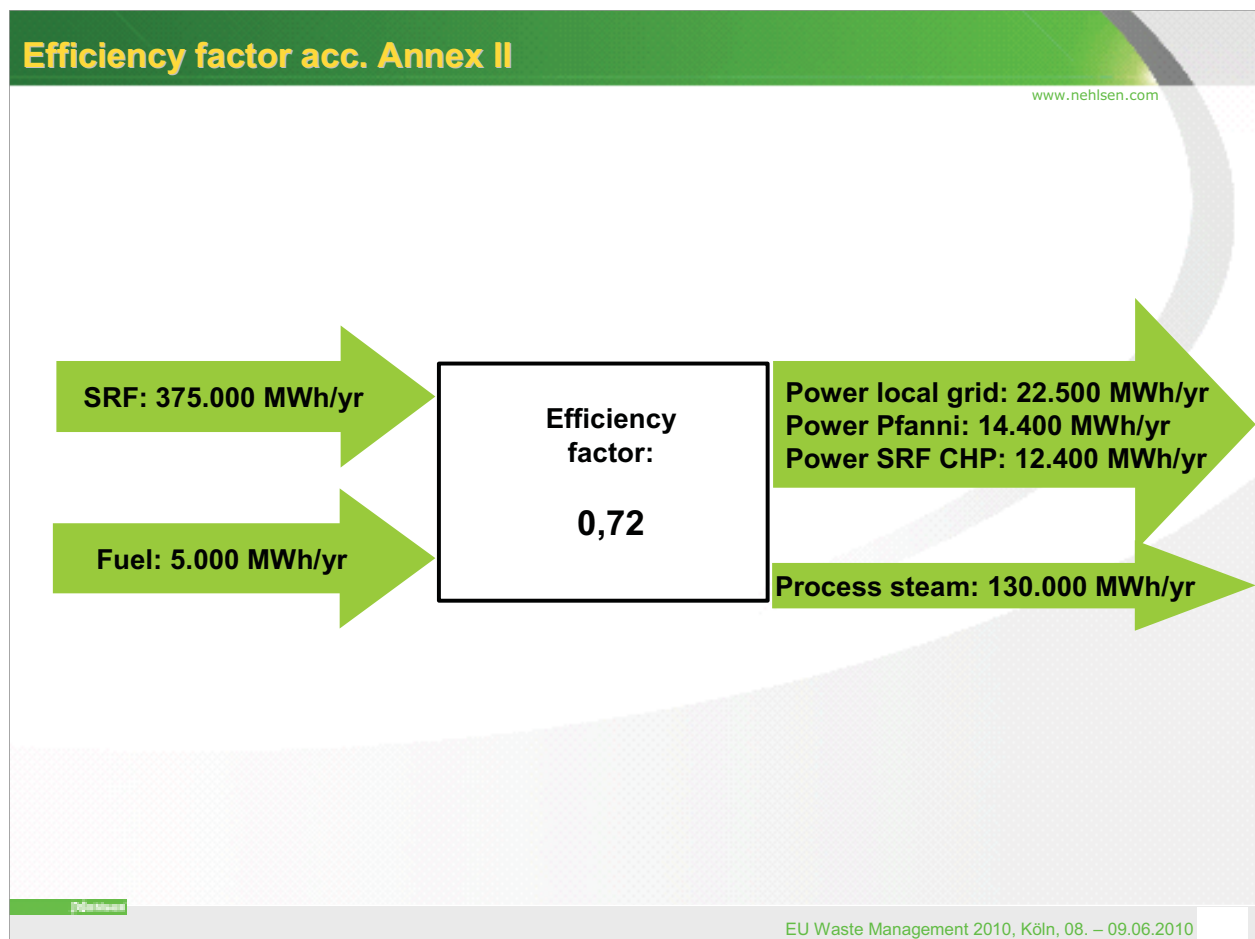
## 5 Zusammenfassung und Wertung

Auch nach zwischenzeitlich dreijährigem Betrieb der Anlage zeigt der Dampferzeuger eine stabile Nennlast von 52 t/h. Der kontinuierlichen Dampfabgabe steht ein sehr dynamischer Prozessdampfbedarf von Pfanni gegenüber, so dass die KWK-Stromproduktion sich ebenfalls sehr dynamisch gestaltet. Im Rahmen von Optimierungsmaßnahmen bei der Day-ahead-Planung der Stromeinspeisung ins vorgelagerte Regionalnetz konnten zwischenzeitlich die Prognosen wesentlich verbessert werden.

Im Rahmen der ersten Revisionen in 07/2008 und 05/2009 nach Reisezeiten von jeweils etwa 8000 h wurden folgende Maßnahmen durchgeführt:

Trockenreinigung des Feuerraums sowie der Berührungsheizflächen

Wanddickenmessprogramm an den rauchgasberührten Druckteilen

Pflege der Feuerfestauskleidung im 1. Zug

Befahrung und Reinigung von Sprühabsorber und Reaktor

Kontrolle des Rostbelags und der Rostkühlung

Überprüfung des Dampfsiebs vor Turbosatz

Überprüfung und fallweiser Austausch der Seile am EBS-Kran

Reinigung der LuKo-Wärmetauscherflächen

Für die Bereiche Feuerraum, 2. und 3. Zug bis Schutzverdampfer vor Überhitzer 3, Überhitzer 1 und 2 sowie Eco-Pakete war eine Trockenreinigung ausreichend.

An Hand eines umfangreichen Wanddickenmessprogramms mit ca. 14.000 Einzelmesspunkten wurden die nicht beschichteten Membranwände, die Berührungsheizflächen der Überhitzerpakete sowie die Eco-Pakete mit einem reproduzierbaren Messraster auf mögliche Abzehrungen hin untersucht.

Das Wanddickenmessprogramm soll auch zukünftig verwendet werden, um ein Wanddickenmonitoring der rauchgasberührten metallischen Oberflächen zu ermöglichen. Die Auswertung der Messprogramme erfolgt über ein spezielles Softwarepaket, das einen Vergleich der Messergebnisse im Sinne eines Lifetime-Monitorings ermöglicht.

An der keramischen Auskleidung des Feuerraums mussten verschiedene Stellen im Bereich der Zünddecke sowie lose Kacheln an den Feuerraumseitenwänden überarbeitet bzw. neu befestigt werden. Eine erste grundlegende Überarbeitung der Feuerfestauskleidung ist für die Revision 2010 vorgesehen.

Im Bereich Sprühabsorber und Reaktor wurden die Sprühdüsen gereinigt. Die Schläuche im Staubfilter zeigten keine Auffälligkeiten.

Rostbelag und Rostkühlung zeigten keine Besonderheiten. Die Abdeckung der Mittelrippe zwischen den beiden Rostbahnen wurde an einer Stelle nachgearbeitet. Kaltaufschweißungen an der Rostbelagsoberfläche, die von Leichtmetallbestandteilen im Brennstoff stammen, wurden entfernt. An der Rosthydraulik sowie an der Hydraulik der Brennstoffaufgabe wurden Dichtmanschetten gewechselt.

Bei der Überprüfung des Frischdampfsiebs vor Turbinenschnellschluss wurden nochmals Partikel mit Korngröße über 250 Mikrometer entfernt. Das Dampfsieb soll als Absicherung der Turbine gegen Feststoffpartikel im Frischdampf zunächst noch eingebaut bleiben.

Die beiden Krangreifer wurden revidiert. Am Hilfszug für einen Personenfahrkorb als Befahr- und Rettungseinrichtung für den Brennstoffbunker wurde prophylaktisch das Seil getauscht.

Die Nassreinigung des LuKo zeigte erhebliche Verschmutzungen der Rippenrohre auf Grund der standortbedingten natürlichen Schwebstoffe einer landwirtschaftlich genutzten, mit Bäumen und Buschwerk bestandenen Umgebung. Da der Schmutzeintrag aus der Umgebung nicht verhindert werden kann, wird auch für zukünftige Revisionen eine LuKo-Wäsche eingeplant.

Die Wiederinbetriebnahme der Anlage nach Revisionsende gestaltete sich jeweils ohne wesentliche Anfahrprobleme, so dass die Turbine nach ca. 14 Revisionstagen planmäßig wieder ans Netz genommen werden konnte.



# French national household waste characterization survey

FANGEAT Erwann

Waste Department Data and Planning, ADEME, Angers, France

## Abstract

Knowledge of the volume and composition of household waste is a key aspect of waste management policy. This knowledge is needed to strengthen waste prevention measures and to put into place treatment processes to extract an ever higher fraction of valuable materials. Under the National Waste Prevention Plan, the Ministry for Ecology, Energy, Sustainable Development and Land Use Planning (MEEDDAT) asked ADEME to conduct a second national survey for the characterization of household wastes (the first one was carried out in 1993). The aim of this characterization campaign is to ascertain the composition of household waste on a national basis, and determine the share of waste from economic activities that is collected by public services.

## Keywords

Household waste, characterisation, waste management

## 1 Methodology

A representative sample was constituted of 100 municipalities randomly selected to represent the country as a whole. Rubbish in these municipalities was collected in two separate containers, one for household waste and the other for waste generated by economically productive activities. Samples of residual household waste were dried, screened and then sorted into 13 categories and 39 sub-categories. Samples of source-separated materials were simply screened, then sorted. Physico-chemical analyses were also carried out. At waste drop-off centres green (yard and garden) waste and demolition waste were weighed, while other waste materials were sorted into the 13 categories. Insofar as possible household waste was distinguished from commercial/business waste. All amounts were recorded in bulk quantities, as collected by public services.

## 2 Noteworthy findings

- Of the total tonnage of residual household waste collected by public services in France, 22% is waste generated by economic activities, representing 4.4 million tonnes in 2007.

- Taking into account the margin of uncertainty in these figures, the composition of household waste has changed very little since the first characterization survey in 1993, with the exception of sanitary textiles.
- The composition of household waste (in percentage) does not differ significantly between types of housing or geographical zones.
- Overall toxicity of residual household waste was lower compared to the level of pollutants measured in 1993.
- Organic waste represents 25% of household waste, roughly 100 kg per capita and per year.
- The proportion of sanitary textiles has increased sharply, and now represents more than 8% of total waste, or 33 kg per capita and per year.
- Half of all newspapers, magazines and packaging collected by public services (including from commercial /business activities) are collected separately from general waste. Accordingly the proportion of paper, cardboard and glass in residual household waste has fallen since 1993.
- Packaging waste (including from commercial/business activities) represents one-third of all household waste (approximately 125 kg per capita annually).

*Table 1 Volume of household waste in 2007 in kg per capita and per year*

<b>Type of collection</b>	<b>Tonnage collected</b>	<b>kg per capita per year</b>
Residual household waste	20.10 million tonnes	316 kg collected per capita per year
Glass collected separately	1.82 million tonnes	29 kg collected per capita per year
Paper and packaging collected separately	2.90 million tonnes	46 kg collected per capita per year
<b>TOTAL HOUSEHOLD WASTE</b>	<b>24.84 million tonnes</b>	<b>391 kg collected per capita per year</b>

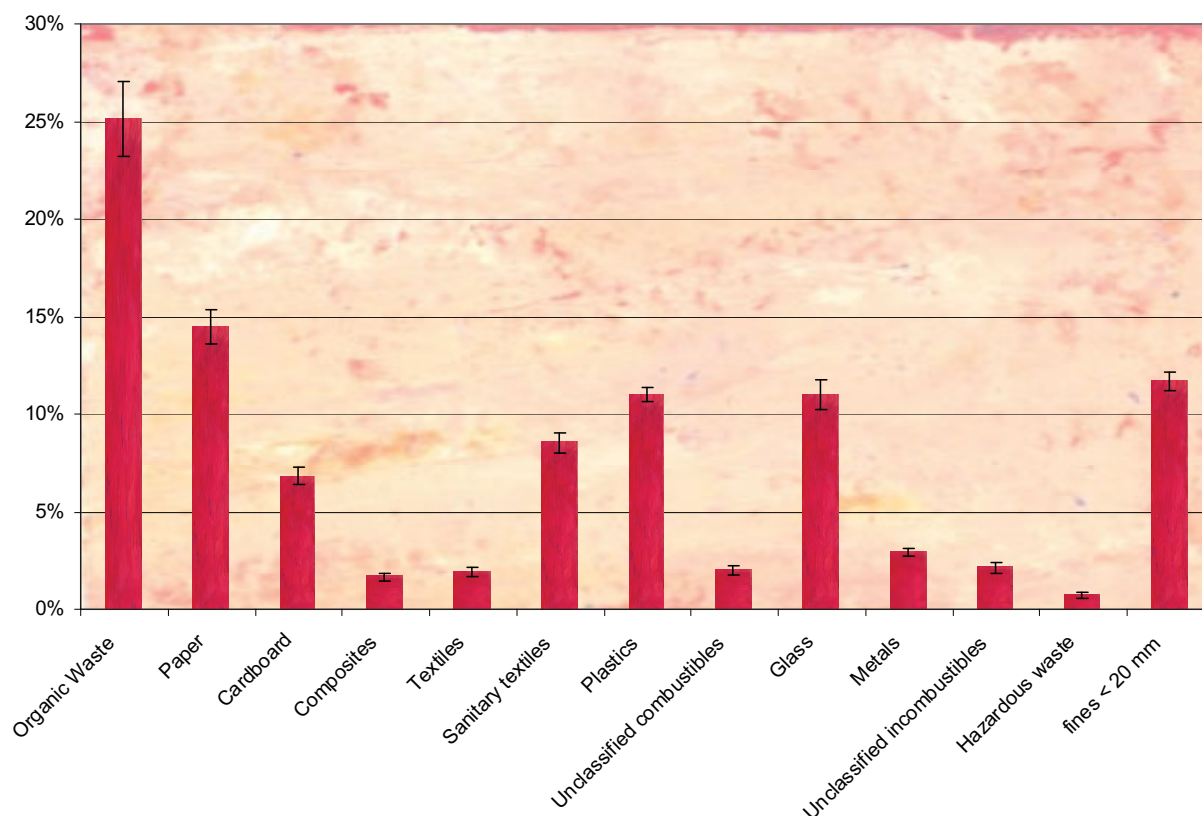

Figure 1 Average composition of household waste nationally

Fines (12% of the total) are composed of 60% organic waste, 13% glass and 19% un-combustible waste.

### 3 Potential scope of waste prevention and recovery of valuable materials

- 39% of total household waste (about 150 kg per capita per year) could be prevented, via home composting, elimination of unaddressed mail, anti-waste campaigns, reduced printing on office equipment, or broader implementation of separate collection for hazardous household waste items.
- Food waste (unconsumed food still in packaging) amounts to 7 kg per capita per year.
- Packaging waste (including from commercial/business activities) represents one-third of all household waste (approximately 125 kg per capita annually).
- Packaging waste (including from commercial/business activities) that corresponds to categories currently covered by waste sorting and diversion schemes, represents less than one-quarter of household waste (88 kg per capita per year).

- 27% of residual household waste (87 kg per capita per year) could potentially be recycled for valuable materials.
- 63% of residual household waste (organic waste, paper, cardboard, sanitary textiles) representing 200 kg per capita par year could be treated using biological processes to extract valuable resources.

#### 4 Trends in household waste composition since 1993

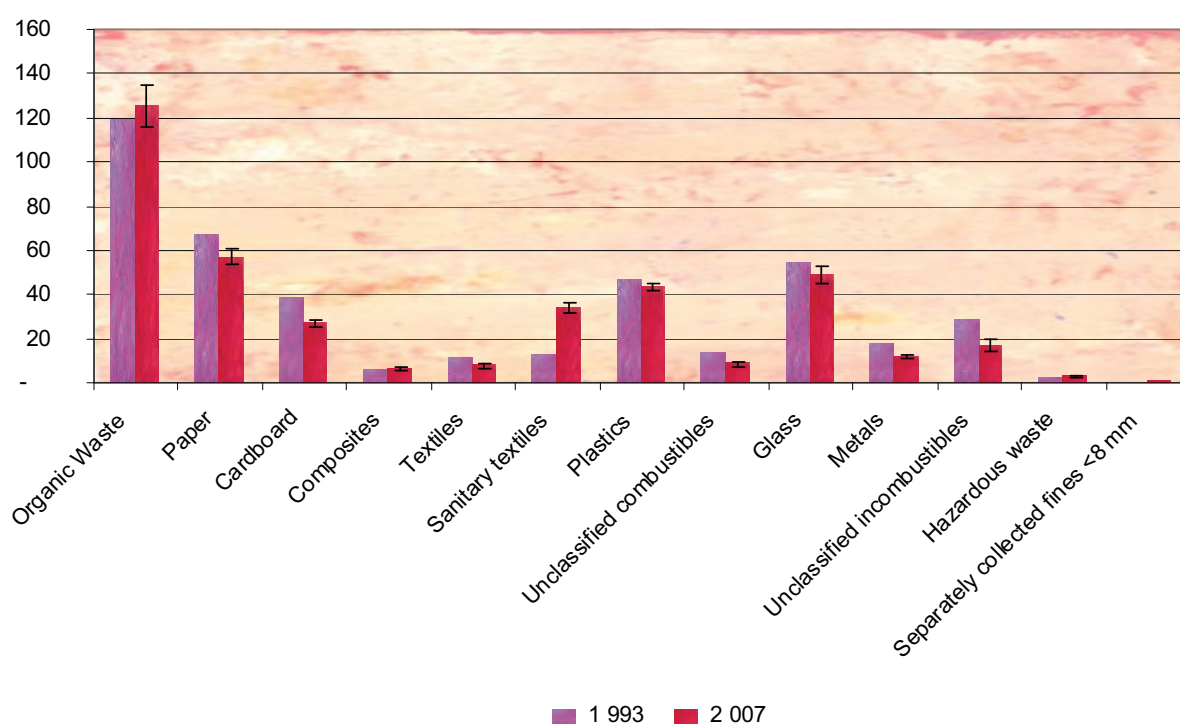

Figure 2 Comparison of household waste per capita, 1993 and 2007, kg per capita per year

Taking into account the margin of uncertainty, the comparison of 2007 figures to 1993 shows no significant difference in the composition of household waste, with the exception of sanitary textiles, which have substantially increased in quantity. Changes in consumption patterns over the last 15 years have had little effect on the composition of household waste. It can be noted, however, that the share of packaging has fallen slightly, from 39% in 1993 to 32% of household waste in 2007.

## 5 Trends in residual household waste since 1993

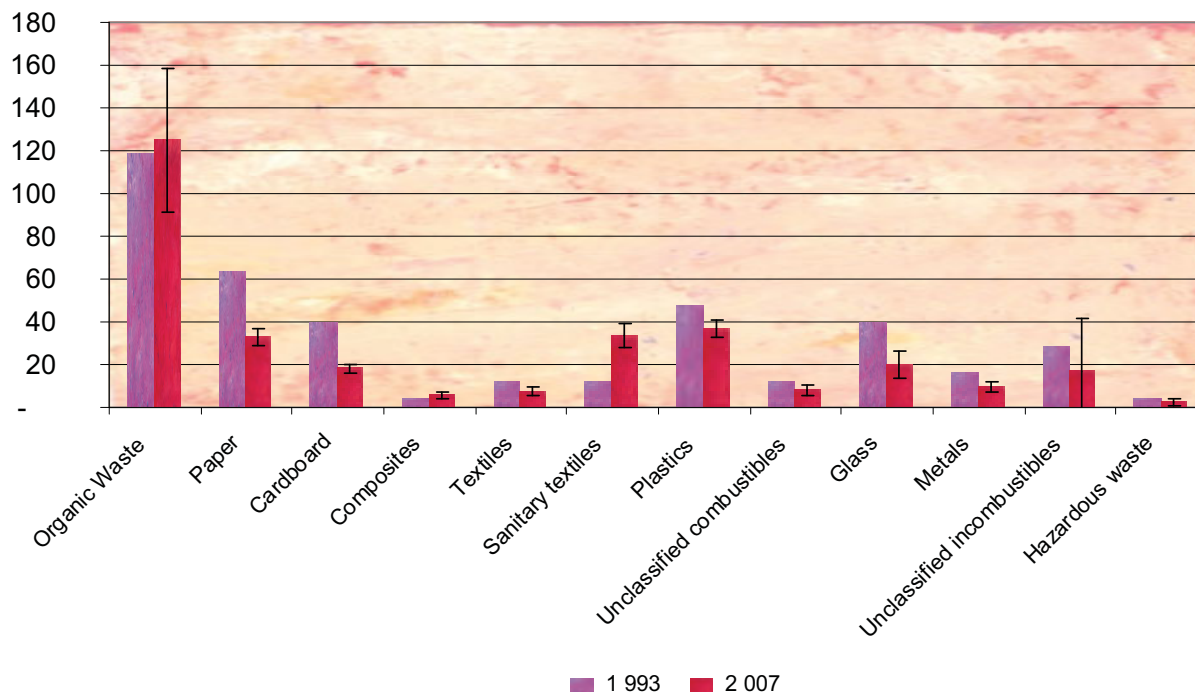

Figure 3 Comparison of residual household waste per capita, 1993 and 2007, kg per capita per year

The composition of residual household waste has changed over the last 15 years. In 1993 waste sorting was still uncommon in France. In 2007 only half as much paper, cardboard and glass was discarded as residual waste compared to 1993.

## 6 The chemical composition of residual household waste

Table 2 chemical composition of residual household waste

Component	Unit	2007	1993	Component	Unit	2007	1993
Humidity content	%	36,7	35,0	Chlorine	mg/kg	2 878	14 000
Total organic matter	%	65,8	59,2	Fluoride	mg/kg	100	58
Sulphur	%	0,17	0,28	Copper	mg/kg	56	1 048
Hydrogen	%	5,2	4,4	Cadmium	mg/kg	1,3	4
Net energy content (wet)	J/g	9 284	7 592	Chromium	mg/kg	87	183
Net energy content (dry)	J/g	16 123	12 992	Nickel	mg/kg	20	48
Gross energy content (dry)	J/g	17 163	13 943	Zinc	mg/kg	301	1000
Organic carbon	%	34,9	33,4	Mercury	mg/kg	0,1	3
Kjeldahl nitrogen	%	1,1		Arsenic	mg/kg	2,5	5
Organic nitrogen	%	0,71	0,73	Selenium	mg/kg	0,22	0,02
Ammonia nitrogen	%	0,014					

## 7 Composition of waste brought to drop-off centres

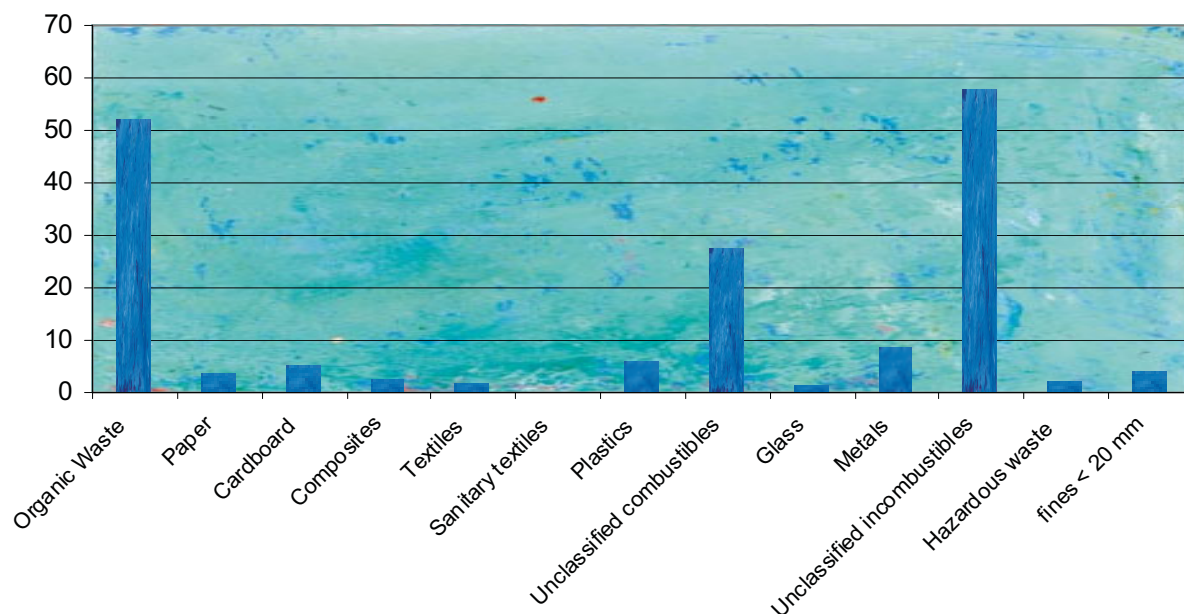

Figure 4 Break-down of waste brought to drop-off centres, kg per capita per year

10.8 million tons of waste were collected in drop-off centres in 2007, the equivalent of 170 kg per capita. These wastes fall into three main categories : organic waste, unclassified incombustible waste (85% of which is rubble) and unclassified combustible items. It has been determined that at least 17% of waste collected at drop-off centres is generated by commercial and business activities.

### Author's address

Fangeat Erwann  
 ADEME  
 20, avenue du Grésillé BP 90406  
 F-49004 ANGERS Cedex 01  
 Telefon +33 2 41 20 43 43  
 Email : [erwann.fangeat@ademe.fr](mailto:erwann.fangeat@ademe.fr)  
 Website: [www.ademe.fr](http://www.ademe.fr)



# Sensor based sorting: A key technology for sustainable waste management

Yunxia Wu, Thomas Pretz

Department of Processing and Recycling, RWTH Aachen University, Aachen, Germany

## Abstract

Waste is a heterogeneous mixture of materials often containing reusable or recyclable materials. In accordance with the hierarchy of the EU requirements “Prevention - Preparing for reuse – Recycling - Other Recovery – Disposal of Waste”, waste processing and recycling additionally fulfills the duty to protect the environment and to preserve primary resources. In order to meet the demands of increasing recycling rates and the quality of recycled waste materials sensor based sorting is playing an important and increasing role in waste processing techniques.

## Keywords

Sensor, sorting, recycling, waste

## 1 Introduction and basics

Physical sorting represents an important step within the unit operations of waste treatment including crushing, screening and separating. The separation technology can be sub-classified in direct and indirect segregation procedures. Direct separation or conventional separation is utilizing interactions between the material properties of single particles and the force fields dependent on the used equipment. This becomes apparent regarding e.g. separation in magnetic fields which allows a selective segregation of ferrous items due to their difference in magnetic susceptibility. However, sensor based sorting is among the indirect separation methods as the working principle initially stipulates a specification of material attributes with detectors like color, electrical conductivity, density and spectral reflection, etc. The actual separation occurs subsequently by digital software based interpretation of the detector signals so that positively recognized particles separately can be blown out of the flight trajectory by compressed air from nozzles (PRETZ, 2005).

Sensor based sorting in waste treatment has evolved substantially since the early 1980s. This represents a technique with non-contact detection which has revolutionized the design of treatment methods, especially in the field of solid waste processing systems. The first phase applications of sensor based sorting devices (chute type sorters) used visible light in order to detect ceramics, stones and porcelain from glass waste. The second phase applications of sensor based sorting devices (belt type sorters) used near infrared detection techniques (NIR) in order to separate recyclable materials like

beverage cartons from collected mixtures of light packaging waste since 1990s (PRETZ AND KILLMANN, 2007). Thus, this method allowed replacing hand sorting by much more powerful machine systems. There were great improvements in technology of sensor based sorting in the last two decades. More than 2000 NIR sorters are already implemented in the recycling industry worldwide (ROBBEN AND WOTRUBA, 2010). Other systems for example color sorting devices as well as machines equipped with induction and x-ray detectors have been used in many fields of waste processing for more than 10 years.

Today, newly developed systems often are operated with a combination of two or more sensors. Thus, machines with a multiple sensor system can guarantee much better separation results especially for sorting of complexly composed waste mixtures in comparison with single sensor devices. In addition, these sensor systems will find new applications for the treatment of various waste mixtures.

## **2 Principles and typical applications of sensor based sorting**

### **2.1 Principles of sensor based sorting**

In general, the most sensor based sorting systems (compare Figure 1 and 2) consist of a material feeder (1) (very often a vibrating conveyor) and a transport unit (1) (sliding chute and/or fast moving belt conveyor) for dissemination and singling of the material flow, a detector system (2) which is arranged below or above the material flow to identify unique features of different materials, an electronic classification unit (3) and a discharge device (4) to separate the identified particles from the material flow. Thus, these two sensor sorters (belt and chute sorters) represent the basic types of construction which are most commonly employed (KILLMANN AND PRETZ, 2006).

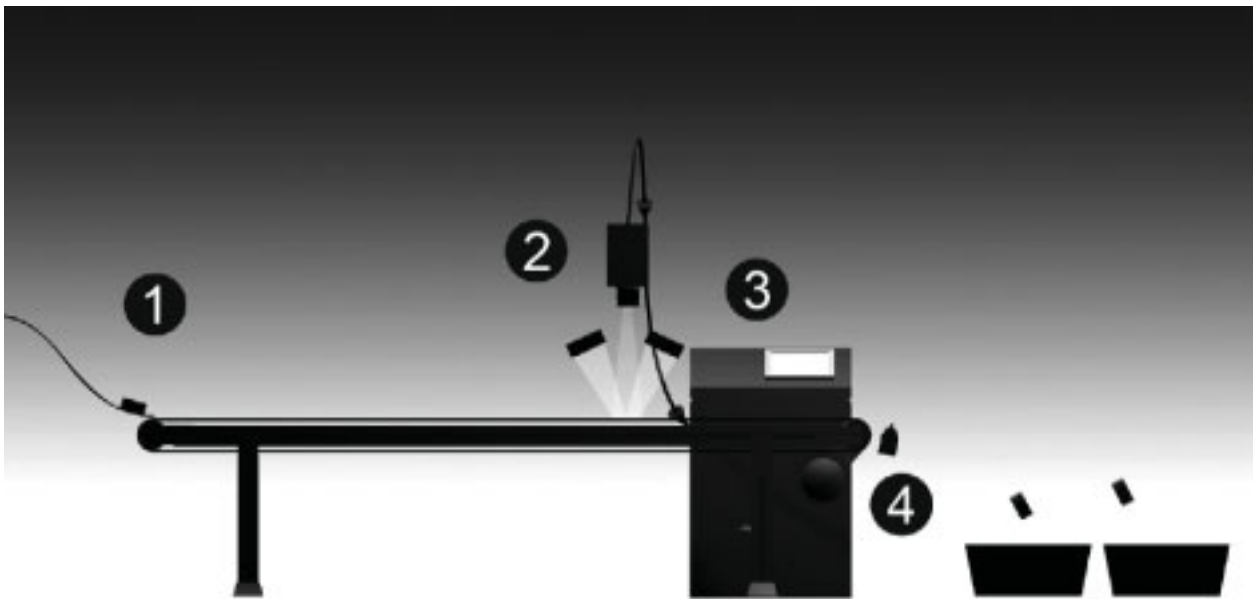

Figure 1 Schematic view of belt sorter (PRETZ AND JULIUS, 2008)

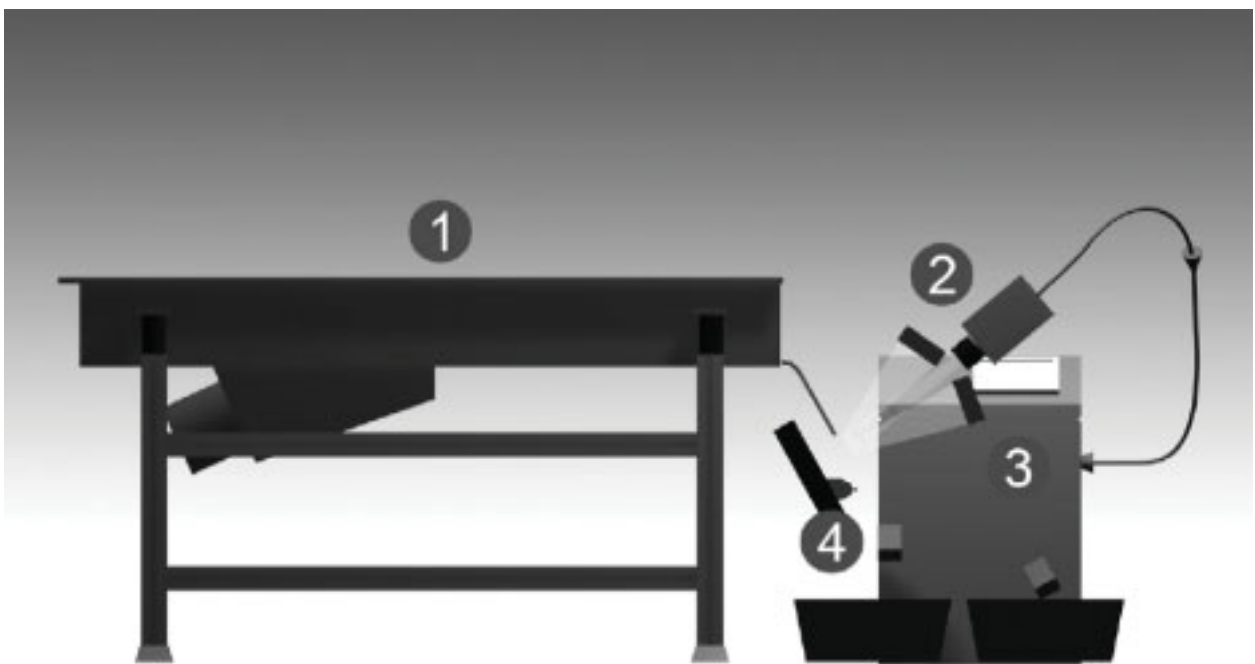

Figure 2 Schematic view of chute sorter (PRETZ AND JULIUS, 2008)

## 2.2 Typical applications

### 2.2.1 Commonly used wavelengths and sensors

Figure 3 shows the most common wavelengths of electromagnetic radiation between gamma rays and acoustic noise which are used in sensor based sorting systems for detection. Frequently employed ranges are the visible light, near infrared and x-ray spectrum. Typical sensors and applications are listed in Table 1 (HABICH, 2010) (KILLMANN AND PRETZ, 2006) (MAKOWE, 2010) (PRETZ AND JULIUS, 2008) (PRETZ AND WOTRUBA, 2008).

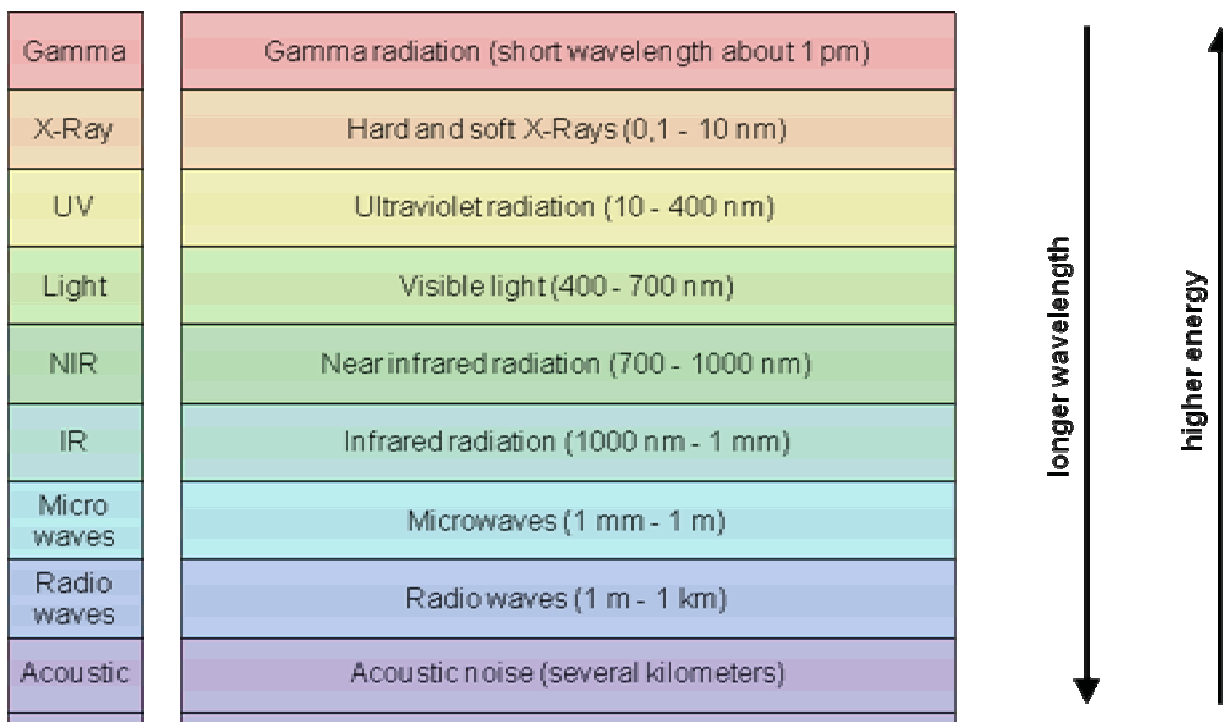

Figure 3 Commonly used wavelengths for detection used in sensor based sorting systems (PRETZ AND JULIUS, 2008)

Table 1 Typical applications of sensor based sorting

Sensors	Separation criterion	Examples for applications
X-ray detectors	Density	Stones, plastics and rubber from wood, copper, stainless steel and copper wires from shredded products, extraction of Zn, Cu alloyed Al from metal mixtures, printed circuit boards extraction from WEEE, extraction of glass ceramics (heat-resistant glass) and leaded glass
Color cameras, VIS (Visible light) spectrometer	Color, brightness	Glass, plastics, PET flakes/resins, copper and brass from NF Metals, circuit boards from electronic scrap, paper sorting
Color cameras	Transparency, luster	Separate magazines from waste paper, separate ceramic/stones/porcelain and heat-resistant glass, determination of lead content in glass recycling
NIR spectrometer	Molecular composition at the surface of material	Bulky waste and wood from other waste, mixed plastics, Paper, wood and textiles from waste mixtures to substitute fuel production, PVC from RDF, paper, cardboards and packaging, detection of flame-retardant additives in polymers
Inductive detectors	electrical conductivity	Wire recovery, metals from incineration slag and shredder residue, stainless steel from metal mixtures, metals from RDF, electronic scrap
Laser (LIBS)	chemical elements	Online metal analysis and sorting of wrought and cast aluminum scrap

### 2.2.2 Color sorting

Applications of color sorting usually are used for the waste glass separation into different colors and contaminants such as ceramics, stones and porcelain. Another application is plastic recycling like PET flakes as recycled PET is used for many applications with high demands on product quality. The employment of CCD color line scan cameras as sensors makes it possible to identify false colored particles with sizes of approx. 2 mm. The contents of impurities below 50 ppm are possible.

### **2.2.3 NIR systems**

Sorting systems with near infrared spectrometers which are arranged over a conveyor belt with a velocity of approx. 3 m/s are state of the art. These devices are successfully applied for sorting of mixed plastics (PVC, PE, PP, PS, PA and many more.), wood and paper recycling. The recovery rate of single plastic types from the mixtures amounts to about 80 to 90 %. The available product purity reaches 90 to 97 wt-percent. New developments for the detection of halogenated flame retardants in polymers with NIR spectral imaging showed positive results. However, it is still impossible to detect black or very dark colored particles with the NIR technology as the amount of reflected light is too low (PRETZ AND JULIUS, 2008).

### **2.2.4 Inductive recognition with so called metal sensors**

In the field of metal sorting conventional devices like magnetic separators for ferrous metals as well as eddy current separators for non ferrous metals commonly are employed. However, in order to recover also stainless steel and other metals which can not be segregated with conventional methods sensor based sorting with inductive detectors successfully is used for these purposes. Other applications for this technology are working with additional sensors like NIR detectors and line scan cameras with the aim of separating of insulated wires and e.g. copper and brass respectively from diverse mixtures. Currently, inductive sorters are able to recognize particles as small as 0.5 mm.

### **2.2.5 Multi sensors**

In general and as mentioned above, the separating results can be improved by using multi sensor systems which contains two or more sensors in order to determine several material properties at the same time. For instance, color sorting is more effective if the position and shape of the feed materials can be determined more precisely. Moreover, these detector systems allow opening up new applications for the separation of waste mixtures which could not be processed before with sufficient success. Table 2 gives an overview about multi sensor combinations and typical applications (BALTHASAR AND REHRMANN, 2010) (VAN DE WINKEL, 2010) (VAN LOOY, 2010).

Table 2 Typical sensor combinations and applications

Sensor combinations	Separation of
NIR + Color Camera	Transparent and opaque, color and black plastics flake sorting
NIR + Induction	Copper wires and printed circuit boards
NIR + Induction + Color Camera	PET Bottles and metals removal
Color Camera + Induction	Waste glass and metals removal
Multi NIR	Different plastics

### 2.2.6 Online material flow analysis

Sensor based recognition systems also can be used for an online-analysis of different waste mixtures which are characterized by their heterogeneous composition with varying ingredients. Conventional offline measurement with very small samples in laboratories is featuring the disadvantage that important parameters e.g. concerning the quality demands of final products can not deliver prompt results. Thus, sensor systems can be used to perform an online analysis of waste parameters like calorific value, water content or material composition. For example, LIBS (laser-induced breakdown spectroscopy) technology allows the determination of the elemental chemical composition of metal products (MAKOWE, 2010) and NIR- detection is suitable for the determination of the calorific values and flame-retardant additives in polymers (LEITNER ET AL., 2010).

## 3 Summary

Sensor based sorting systems have applications in waste treatment since approx. 30 years. The continuing development of new sensor systems keeps opening up new fields of application. Sensor based sorting is as key technology for sustainable waste management more and more necessary.



## 4 Literature

- Pretz, T.; Julius, J. 2008 Österreichische Wasser- und Abfallwirtschaft. Stand der Technik und Entwicklung bei der berührungslosen Sortierung von Abfällen. SpringerWienNewYork Verlag, Wien, Heft 07-08/2008, S.105-112.
- Leitner, R.; McGunnigle, G.; Kraft, M.; De Biasio, M.; Rehrmann V.; Balthasar, D. 2010 Tagung Sensor gestützte Sortierung 2010. NIR Spectral Imaging for Industrial Detection of Flame-Retardant Additives in Polymers. Schriftreihe der GDMB Gesellschaft für Bergbau, Metallurgie, Rohstoff- und Umwelttechnik (Hrsg.), S.63-64, ISBN 978-3-940276-24-7.
- Makowe, J. 2010 Tagung Sensor gestützte Sortierung 2010. Chemische Online-Analyse von Stoffströmen – Prozesskontrolle und automatische Sortierung mit Lasertechnik. Schriftreihe der GDMB Gesellschaft für Bergbau, Metallurgie, Rohstoff- und Umwelttechnik (Hrsg.), S.65-66, ISBN 978-3-940276-24-7.
- Pretz, T. 2005 Sortiertechnik - Sensorgestützte Sortierung in der Abfallwirtschaft. Vortrag auf Trieren Gespräche zur Abfallwirtschaft“, FH Trier, Juni 2005.
- Killmann, D.; Pretz, T. 2006 Possibilities of sensor based sorting regarding recycling of waste. Acta Metallurgica Slovaca, WSRM 06 Slovakia, S.188-193, ISSN 1335-1532.
- Robben, M.; Wotruba, H. 2010 Tagung Sensor gestützte Sortierung 2010. Near-infrared Sorting for Minerals. Schriftreihe der GDMB Gesellschaft für Bergbau, Metallurgie, Rohstoff- und Umwelttechnik (Hrsg.), S.11, ISBN 978-3-940276-24-7.
- Habich, U. 2010 Tagung Sensor gestützte Sortierung 2010. Veränderung von Aufbereitungsprozessen durch sensorgestützte Sortiersysteme. Schriftreihe der GDMB Gesellschaft für Bergbau, Metallurgie, Rohstoff- und Umwelttechnik (Hrsg.), S.9, ISBN 978-3-940276-24-7.
- Pretz, T.; Killmann, D. 2007 Müll und Abfall. Innovative Sortiertechnologien zur Gewerbeabfallsortierung. 11/2007, S.546-551, ISSN 0027-2957.
- Pretz, T.; Wotruba, H. 2008 Tagung Sensor gestützte Sortierung 2008. Stand der Technik der sensorgestützten Sortierung. ISBN 978-3-940276-10-0.

- Van Looy, E. 2010 Tagung Sensor gestützte Sortierung 2010. EcoTowerSort. Schriftreihe der GDMB Gesellschaft für Bergbau, Metallurgie, Rohstoff- und Umwelttechnik (Hrsg.), S.37-39, ISBN 978-3-940276-24-7.
- Balthasar, D.; Rehrmann, V. 2010 Tagung Sensor gestützte Sortierung 2010. Flake Sorting based on Visual and Infrared Spectroscopy. Schriftreihe der GDMB Gesellschaft für Bergbau, Metallurgie, Rohstoff- und Umwelttechnik (Hrsg.), S.17-18, ISBN 978-3-940276-24-7.
- Van de Winkel, F. 2010 Tagung Sensor gestützte Sortierung 2010. Dry sorting of Non-Ferrous Metals – Practical Experiences with Sensorbased Sorting. Schriftreihe der GDMB Gesellschaft für Bergbau, Metallurgie, Rohstoff- und Umwelttechnik (Hrsg.), S.61, ISBN 978-3-940276-24-7.

### **Author's address(es)**

Dipl.-Ing. Yunxia Wu  
Department of Processing and Recycling  
RWTH Aachen University  
Wüllnerstr. 2  
D-52062 Aachen  
Telefon +49 241 80 96 123  
Email [wu@ifa.rwth-aachen.de](mailto:wu@ifa.rwth-aachen.de)  
Website: [www.iar.rwth-aachen.de](http://www.iar.rwth-aachen.de)

Univ. Prof. Dr.-Ing. Thomas Pretz  
Department of Processing and Recycling  
RWTH Aachen University  
Wüllnerstr. 2  
D-52062 Aachen  
Telefon +49 241 80 95 700  
Email [pretz@ifa.rwth-aachen.de](mailto:pretz@ifa.rwth-aachen.de)  
Website: [www.iar.rwth-aachen.de](http://www.iar.rwth-aachen.de)

# Comparison of Methods for the Treatment of Mixed Municipal Waste from Households

Josef Mitterwallner & Wilhelm Himmel

Amt der Steiermärkischen Landesregierung, Fachabteilung 19D, Graz

## Vergleich von Verfahren zur Behandlung von gemischten Siedlungsabfällen aus Haushalten

### Abstract

The “biological-thermal-way” for treatment of municipal solid waste (MSW) in the Styria region has been compared to the “thermal-only-way” by ecological and economical operating figures. The method of the study was to list data of 10 mechanical treatment plants (MTs), 6 biological treatment plants (BTs), 5 thermal treatment plants (TTs) and 4 landfills (LFs) in order to generate mass balances, energy balances, greenhouse gas emission balances as well as cost-balances. The study shows the commitment of the Styrian region to the principle in waste management “recycling before disposal“, mainly seen at the landfill volume demand which is considerably low (0.35-0.4 m<sup>3</sup>/t MSW). The greenhouse gas emission calculation includes the substitution of fossil energy sources according the applied method from the Intergovernmental Panel on Climate Change (IPCC). The study showed that the replacement of coal by natural gas can change considerably the greenhouse gas emission balance of the waste management in a region. The energy-balances, greenhouse-gas emission balances and cost balances of the mechanical-biological-thermal waste treatment concept and the single thermal waste treatment concept with heat recovery and electricity production showed similar results.

### Inhaltsangabe

Der biologisch-thermische Weg der Behandlung von Restabfall in der Steiermark wurde mit dem rein-thermischen Weg an Hand ökologischer und ökonomischer Kennzahlen grundlegend verglichen. Für die vorliegende Studie wurden Daten von 10 mechanischen Abfallbehandlungsanlagen, 6 biologischen Abfallbehandlungsanlagen, 5 thermischen Abfallbehandlungsanlagen und 4 Deponien erhoben, um Massebilanzen, Energiebilanzen, CO<sub>2</sub>-Bilanzen und Kostenbilanzen zu erstellen. Die Studie zeigt, dass sich die Steiermark zum abfallwirtschaftlichen Grundsatz „Verwerten vor Beseitigen“ bekennt, was insbesondere im relativ geringen Deponievolumenverbrauch von 0,35 bis 0,4 m<sup>3</sup>/t Restmüll zum Ausdruck kommt. Die CO<sub>2</sub> Bilanz inkludiert die Substitution von fossilen Energieressourcen entsprechend den Vorgaben des Intergouvernemental Panel of Climate Change (IPCC). Die Studie zeigte, dass der Ersatz von Steinkohle durch Erdgas die CO<sub>2</sub> Bilanz der Abfallwirtschaft einer Region signifikant verändern kann. Die Energie- CO<sub>2</sub>- und Kosten-Bilanzen des steirischen MBA-Konzeptes bzw. des rein thermischen Abfallbehandlungskonzeptes mit Strom und Abwärmenutzung haben annähernd vergleichbare Ergebnisse geliefert.

### Keywords

MBA, thermische Abfallbehandlung, Energiebilanz, CO<sub>2</sub>-Emissionen, Restmüll

MBT, thermal waste treatment, energy-balance, greenhouse gas emissions, MSW

## 1 Introduction

The aim of the present study was a reliable comparison of two main municipal solid waste (MSW) treatment methods, the biological-thermal way and the thermal-only way. The biological-thermal method includes mechanical pre-treatment to separate the MSW mainly in two fractions, one for composting (undersize fraction) and the other for incineration (oversize fraction), i.e. Solid Recovered Fuel. The subsequent biological and thermal treatments produce compost as a biologically stable product and incineration residues both for disposal in landfills.

In the Austrian province of Styria the biological-thermal treatment of MSW starts in the 1990s and was established for the whole region in 2004 to comply with the Austrian Landfill Ordinance. Because of continuous discussions between stakeholders of the two treatment ways reliable parameters would help to gain objective evidence of the pros and cons of the two methods for a whole region.

Three criteria should be evaluated by the present study:

- 1) economy (treatment costs without profits and losses),
- 2) global warming potential (greenhouse gas emissions, energy balance sheet) and
- 3) regional impact (jobs, surplus treatment capacities, number of treatment companies, waste fee for the average household).

In this paper MSW means residual waste from households. In the region of Styria besides the residual waste bin further separate collection from households exists for organic waste, for paper and cardboard waste, for plastic and metal packaging waste and for bulky waste. In 2007 there were produced 123 kg of residual waste per capita.

## 2 Method

Sources of the numerous data were the official data of the Styrian Government, Department 19D "Waste and Material Flow Management", plant visits and answers of plant operators to a questionnaire. Furthermore numerous literature was consulted.

The actual MSW treatment situation of Styria is the biological-thermal way which is described for the year 2007. Two thermal-only treatment plants in neighbouring regions were chosen to describe alternative scenarios, called the "Thermal-only way 1" and the "Thermal-only way 2". For these scenarios it was assumed to bring 100% MSW of Styria to these thermal treatment plants (TTs), as if there existed no biological-thermal treatment.

So three models were calculated:

1. "Biological-thermal", i.e. actual situation of Styria in 2007: The >80 mm oversize fraction (36% of MSW) is brought to two fluidized bed incineration TTs, both supplying electricity and steam to neighboring industry plants, a fibre factory and a paper factory. The energy efficiency factors of the TTs are 9.4 and 12.8% net electric efficiency (production minus consumption) and 57.2% and 63.5% net heat efficiency. Minor quantities of the oversize (6% of MSW) were brought to a cement factory. 55% of MSW were brought to biological treatment plants and 3% of MSW were metal fractions for recycling.
2. „Thermal-only 1“, i.e. complete thermal treatment in a grid incineration TT in Upper Austria, where electricity is produced for the grid. The net electric efficiency factor is 18.6% (Boehmer et al. 2007).
3. "Thermal-only 2", i.e. complete thermal treatment in a grid incineration TT in Lower Austria, where electricity and steam are produced. The steam goes to a neighboring coal power plant. The energy efficiency factors are 12.8% net electric efficiency and 16.4% net heat efficiency (Anonymous 2007). The net heat efficiency includes the efficiency of the coal power plant of 42.6% (electricity only).

The method of the study was to list data for 10 mechanical treatment plants (MTs), 6 biological treatment plants (BTs), 5 thermal treatment plants (TTs) and 4 landfills (LFs) to generate a mass balance, an energy balance, a greenhouse gas emissions balance (Eggleston et al. 2006) as well as a calculation of the treatment costs. Waste collection was excluded from the study. Transport expenditures start at the MTs and end up at the LFs or at recycling plants (steel mill, aluminium mill, cement plant). This was done for each single plant and afterwards the overall sum was calculated to get the figure for the whole region. At the end a sensitivity analysis was made to identify crucial input parameters of the calculation.

In Figure 1 the greenhouse gas emissions balances of all observed treatment steps, separated in production, credits and summation are shown.

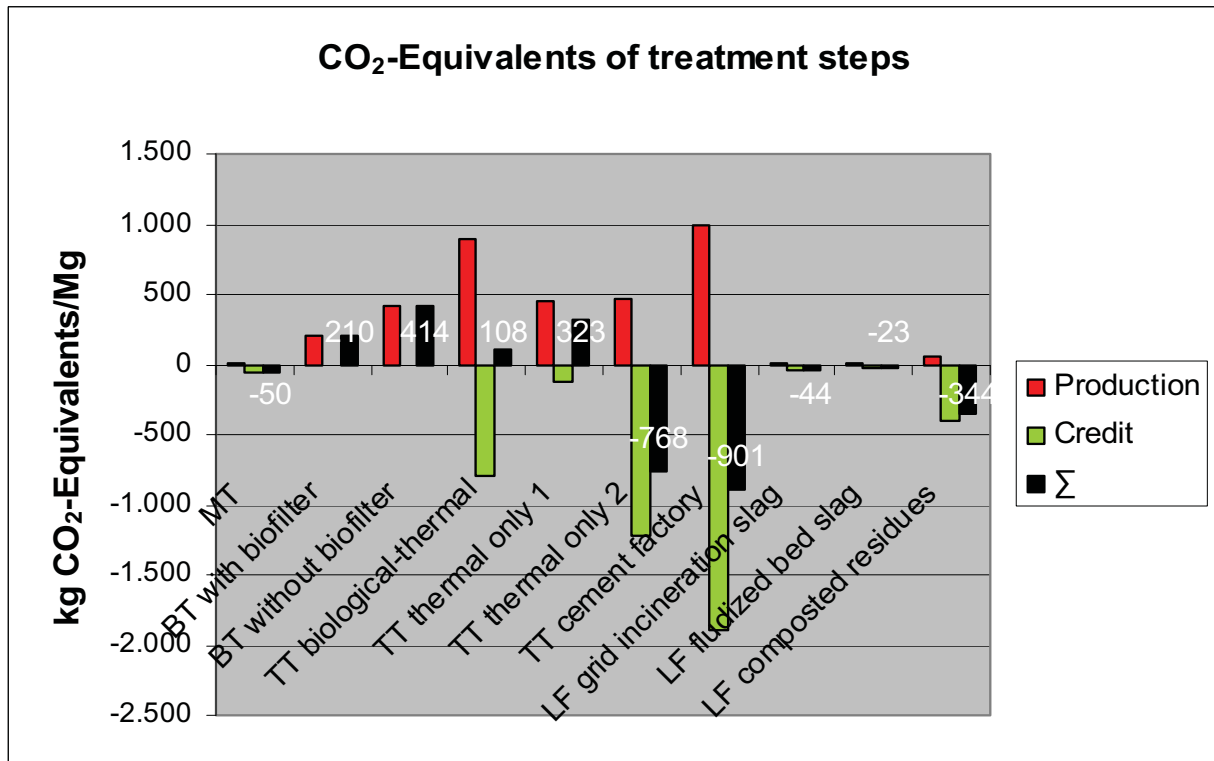

**MT Mechanical treatment plant, BT Biological treatment plant, TT Thermal treatment plant, LF Landfill**

Figure 1: Greenhouse gas emissions balances of all observed treatment steps, separated in production, credits and summation. Production (positive figures) includes fossil CO<sub>2</sub>-equivalents emissions by energy consumption and burning of fossil carbon waste composites (plastic). Credits (negative figures) include the replacement of fossil fuels by the production of heat, electricity and scrap and carbon storage via the compost disposal to the LFs

### 3 Results

In Styria in 2007 145.785 Mg of municipal solid waste were produced. The waste was delivered to 10 MTs for pre-treatment. There 79.573 Mg of undersize material (<80 mm) were separated and sent to 6 BTs for composting. 61.122 Mg of oversize material (>80 mm) from the MTs were sent to 2 TTs. Additionally 5.301 Mg of magnetic and non-magnetic metal scrap were separated in the MTs from the MSW. The quantity of the MSW input was reduced to 62.742 Mg (42%) due to the gaseous losses during composting and incineration. Finally 54.649 Mg (38%) were disposed to LFs. In Figure 2 the specific demand of landfill volume per Mg MSW is shown for the biological-thermal way and the two thermal-only scenarios.

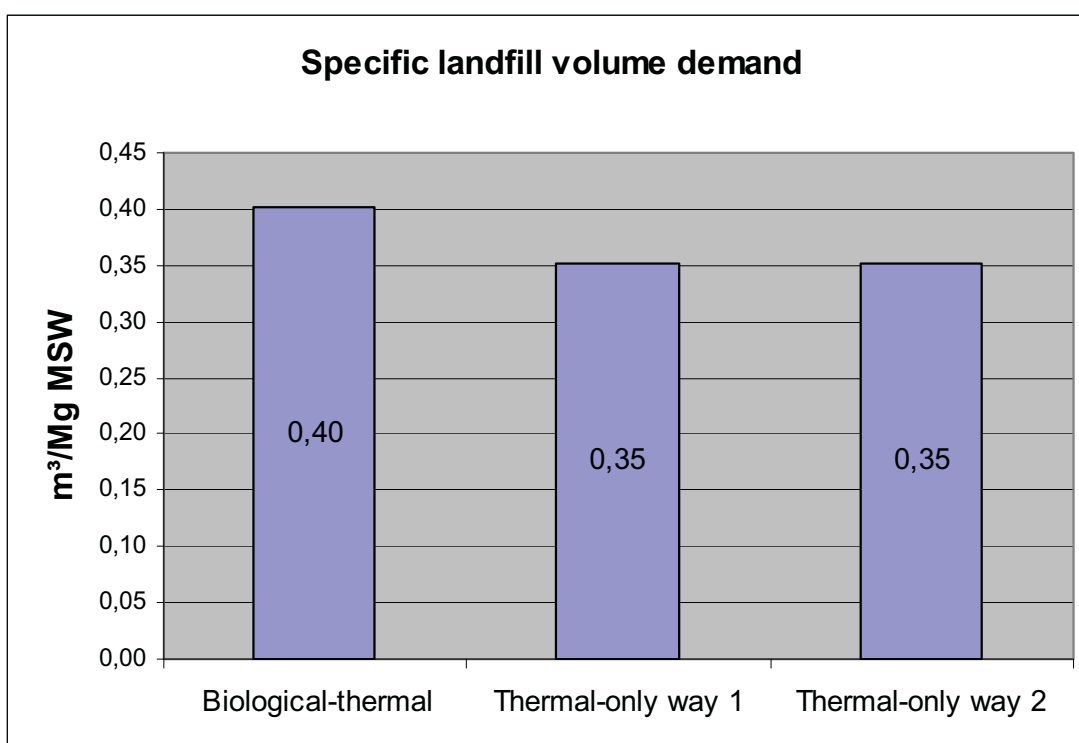

Figure 2: Specific demand of landfill volume after MSW treatment of the biological-thermal way (i.e. Styria in 2007) compared with the scenarios "Thermal-only way 1" and "Thermal-only way 2"

The energy balance of the MSW-treatment in Styria in 2007 showed up a total account of 116 GWh, which could be generated from the waste in the energy forms electricity and heat. The specific energy balance was -793 kWh/Mg MSW (the negative figure represents accounts), those of the thermal-only ways was -821 kWh/Mg and -308 kWh/Mg, see Figure 3.



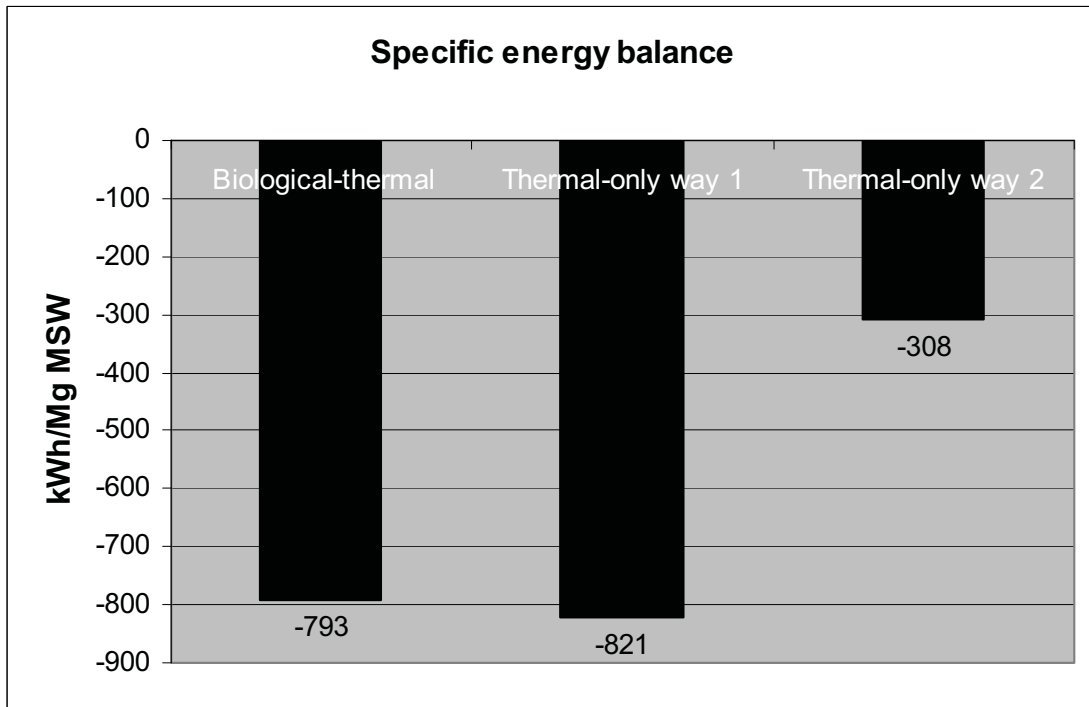

Figure 3: Specific energy balance of the biological-thermal way (i.e. Styria in 2007) compared with the scenarios “Thermal-only way 1” and Thermal-only way 2”

The costs of the MSW-treatment in Styria in 2007 run up to € 13 million for treatment without profits and losses. The specific costs of the MSW-treatment run up to 89 €/Mg, those of the thermal-only ways to 94 €/Mg (+ 6%) and 133 €/Mg (+ 49%), see Figure 4.

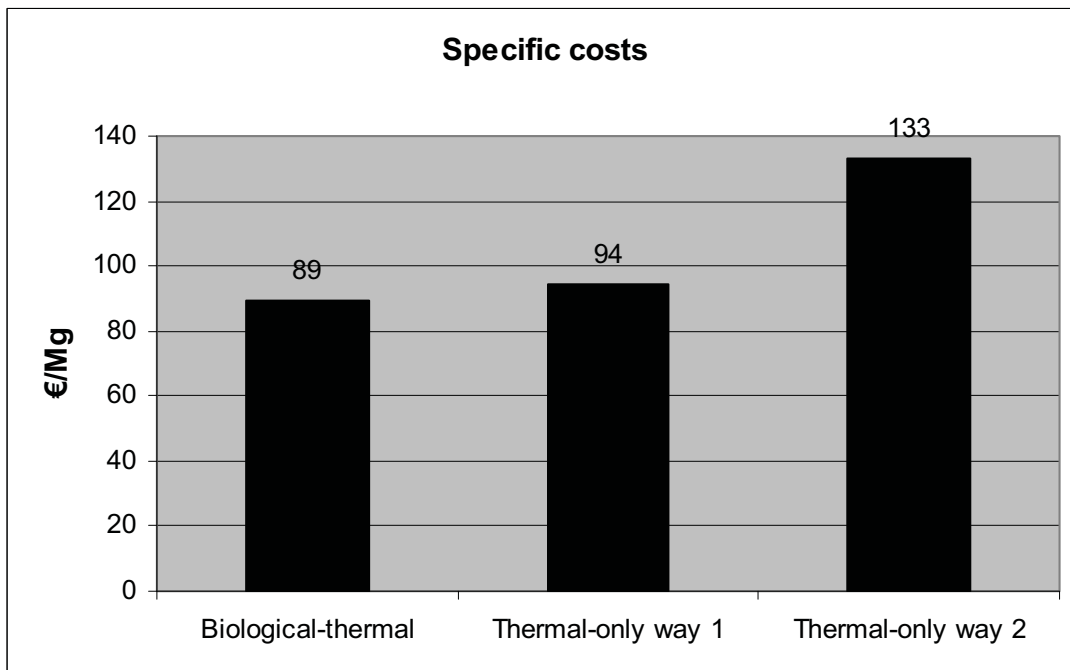

Figure 4: Specific costs of MSW treatment of the biological-thermal way (i.e. Styria in 2007) compared with the scenarios “Thermal-only way 1” and Thermal-only way 2” (without profits and losses)

Specific costs of MSW-treatment of Styrian plants are 14-40 €/Mg for MTs, 30-55 €/Mg for BTs, 34-122 €/Mg for TTs and 39-50 €/Mg for LFs.

The greenhouse gas emission balance results of MSW-treatment in Styria in 2007 show an overall credit of 7 Gg CO<sub>2</sub>-Equivalents, i.e. more CO<sub>2</sub>-Equivalents were avoided than produced. The specific CO<sub>2</sub>-Equivalents emissions run up to -48 kg/Mg MSW (credit) for the biological-thermal way, -771 kg/Mg MSW (credit) for the thermal-only way 1 and +327 kg/Mg MSW (emission) for the thermal-only way 2, see Figure 5.

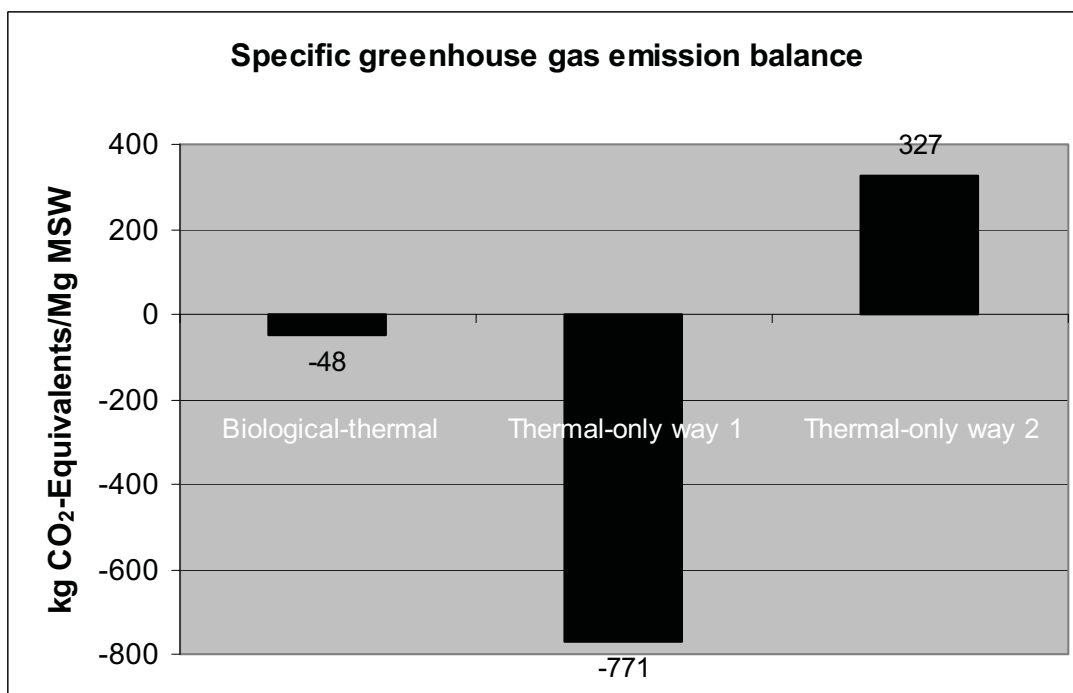

Figure 5: Specific greenhouse gas emission balance of the biological-thermal way (i.e. Styria in 2007) compared with the scenarios “Thermal-only way 1” and “Thermal-only way 2” (negative figures represent credits, positive figures represent emissions)

The sensitivity analysis for the scenario “Thermal-only way 1” shows a crucial influence of the replaced fossil energy source, e.g. if natural gas is replaced instead of coal by the steam production of the TT for the neighboring power plant, see Figure 6.

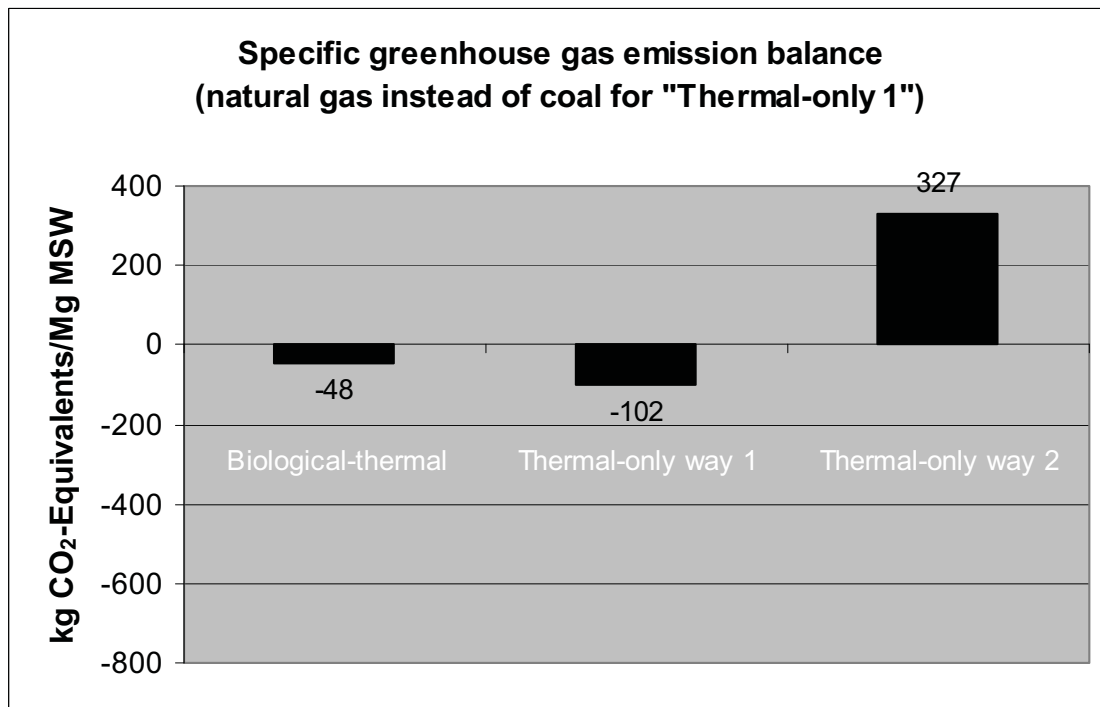

Figure 6: Sensitivity analysis for the scenario "Thermal-only way 1". Natural gas was replaced instead of coal by the steam production in the TT for the power plant. The biological-thermal way and the thermal-only way 2 were not changed.

Specific greenhouse gas emissions of MSW-treatment of Styrian plants are -7 to -84 kg CO<sub>2</sub>-Equivalents/Mg for MTs (credits for scrap recycling), 187 to 414 kg CO<sub>2</sub>-Equivalents/Mg for BTs (mainly by CH<sub>4</sub>-emissions), -901 to +169 kg CO<sub>2</sub>-Equivalents/Mg for TTs and 0 to 0,3 kg CO<sub>2</sub>-Equivalents/Mg for LFs.

Up to now no correlation between way of treatment and disposal fees for households was found (Anonymous 2005b). Available data vary notably and are difficult to compare because the costs are related to different household-units, e.g. per household or per bin in combination to the disposal interval. Furthermore the definition of the related unit sometimes is different, e.g. 3-person household or 4-person household. However a comparison was done and shows a cheap waste disposal fee in Styria compared to Vienna and the medium Austrian fee. Compared to Bavaria and Germany fees are similar, see Figure 7.

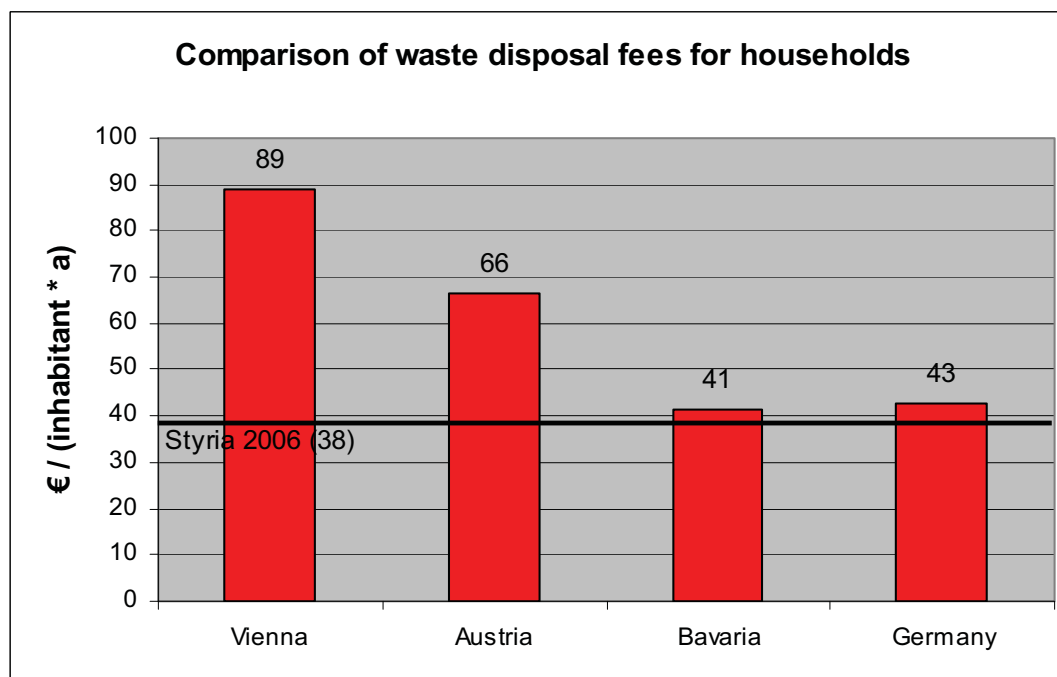

Figure 7: Comparison of waste disposal fees for households in different regions (Rogalsky 2008, Himmel 2008, Anonymous 2008)

The most important results are summarized in Table 1.

Table 1: Overview of the results of the biological-thermal way (i.e. Styria in 2007) compared with the scenarios "Thermal-only way 1" and Thermal-only way 2". Mg refers to Mg Input MSW. Negative figures represent credits.

	Biological-thermal	Thermal-only way 1	Thermal-only way 2
Energy balance	-793 kWh/Mg	-821 kWh/Mg	-308 kWh/Mg
Treatment costs	89 €/Mg	94 €/Mg	133 €/Mg
Greenhouse gas emission balance	-48 kg/Mg	-771 kg/Mg	327 kg/Mg
Landfill volume demand	0,4 m <sup>3</sup> /Mg	0,35 m <sup>3</sup> /Mg	0,35 m <sup>3</sup> /Mg
Jobs	50	39	48

## 4 Conclusions

The present study shows the commitment of the Styrian region to the principle in waste management "recycling before disposal" (Anonymous 2005a), mainly seen at the landfill volume demand which is considerably low (0,35-0,4 m<sup>3</sup>/Mg MSW). Above that the results give approaches to enhance this principle:

- There is still potential to reduce the organic content of residual waste. This fraction should be shifted to the organic household waste bin by the resident himself for subsequent recycling in the form of compost.

- 5 of 10 mechanical waste treatment plants of Styria do not apply eddy current separators to gain non-ferrous scraps and this valuable fraction is still disposed to landfills. There should be a legal obligation for the operators to recycle non-ferrous metals.
- The quality of ferrous and non-ferrous scraps is improvable. Now the scraps still contain considerably quantities of non-metal contaminants (up to 30%, mainly plastic and textiles). To enhance recycling of metals and improve the purity of the metal waste fraction the existing separate collection of metal packaging material should be enlarged for any kind of metals. Furthermore the use of combined screening and ballistic separation instead of usual screening and wind sifting would produce considerably better scrap purities.

The greenhouse gas emission calculation includes the substitution of fossil energy sources according the applied method from the Intergovernmental Panel on Climate Change (IPCC) (Eggleston et al. 2006). The study showed that the replacement of coal by natural gas can change considerably the greenhouse gas emission balance of the waste management of a region even though it does not have to do anything with the waste business. However the mixture of fossil energy source varies from region to region. So a comparison of the greenhouse gas emissions from waste management of two regions must consider this fact.

The disposal of waste residues to landfill rank among the duties of waste management. Applying the biological-thermal treatment of MSW the piling of carbon within the landfills reduces CO<sub>2</sub>-emissions. Even though they are non-fossil they help to reduce the release of CO<sub>2</sub> to the atmosphere. The thermal-only way is not able to pile carbon in landfills.

The criteria for choosing one of the two investigated ways of treatment for a certain region are mainly the population density and the existence of relevant industry with capacities for waste incineration for heat and power generation. Positive criteria for the biological-thermal way are:

- Low population density (<200 inhabitants/km<sup>2</sup>)
- Easily accessible industrial waste incineration plants >40 MW input heat capacity
- Political commitment for a maximum recycling of wastes
- Existing mechanical and biological treatment plants, which show flexibility towards changes

Positive criteria for the thermal-only way are:

- High population density (>200 inhabitants/km<sup>2</sup>)
- Suitable sites for the operation of thermal-only incineration plants
- Reliability of waste management planning for about 20 years.

The present study for the Styria region with 1.2 million inhabitants and the surface area of 16,392 square kilometres shows that both ways do achieve similar energy balances, costs and greenhouse gas emission balances. However the results depend strongly on the regional characteristics.

The advantages of the biological-thermal way are:

- Flexibility towards changes in waste quantities and waste composition
- General recycling enhancement
- Strengthening of the region: economic diversity, more jobs in the region, the waste treatment know-how stays within the region, low waste fees for households
- Public acceptance of smaller treatment units
- Minimisation of transport expenditures
- Carbon storage within landfills

## 5 Literature

- |           |       |   |
|-----------|-------|---|
| Anonymous | 2005a | Landes-Abfallwirtschaftsplan Steiermark 2005. Government of Styria, Department 19D „Waste and Material Flow Management“, Graz.  |
| Anonymous | 2005b | <i>Einflussfaktoren auf die Höhe der Müllgebühren. Kammer für Arbeiter und Angestellte, Wien.</i><br><a href="http://www.arbeiterkammer.at/bilder/d49/InformationenUmweltpolitik164.pdf">www.arbeiterkammer.at/bilder/d49/InformationenUmweltpolitik164.pdf</a> (Jan. 12, 2009) |
| Anonymous | 2007  | <i>EVN Nachhaltigkeitsbericht 2006/07. Energie Versorgung Niederösterreich, Maria Enzersdorf.</i>   |
| Anonymous | 2008  | <i>Abfallgebühren in Bayern liegen deutlich unter Bundesdurchschnitt. Euwid No. 25 on Jun. 17, 2008, pp. 25</i>   |

- Böhmer, S., 2007 *Abfallverbrennung in Österreich - Statusbericht 2006. UBA Report 0113. Umweltbundesamt GmbH Wien.*  
 Kügler, I. Stieber, H. & Walter, B.
- Eggleston, S., 2006 *2006 IPCC Guidelines for National Greenhouse Gas Inventories. Published by the Institute for Global Environmental Strategies (IGES), Hayama, Japan; www.ipcc-nggip.iges.or.jp/public/2006gl/index.html (Jan. 12, 2009)*  
 Buendia, L., Miwa, K. Ngara, T. & Tanabe, K.
- Himmel, W.; 2008 *Die Zukunft der Müllgebühren bei steigenden Sekundärrohstoffpreisen. Presentation at the Entsorgungstag 2008 Vösendorf. Department 19D „Waste and Material Flow Management“, Government of Styria.*
- Rogalsky, W.; 2008 *Sammlung und Behandlung biogener Abfälle in Wien. Presentation at the ERFA Wels 2008. Department 48, Municipality of Vienna.*

**Anschrift der Verfasser:**

Dipl.-Ing. Josef Mitterwallner & Dipl.-Ing. Dr. Wilhelm Himmel  
 Amt der Steiermärkischen Landesregierung  
 Fachabteilung 19D, Abfall- und Stoffflusswirtschaft  
 A-8010 Graz  
 Telefon +43 316 877 2157  
 Email: josef.mitterwallner@stmk.gv.at  
 Telefon +43 316 877 2157  
 Website: [www.abfallwirtschaft.steiermark.at](http://www.abfallwirtschaft.steiermark.at)



# **Pre-Processing of Municipal Solid Waste before Anaerobic Digestion - CAPEX and OPEX as model calculation**

**Dr.-Ing. Michael Langen**

HTP Ingenieurgesellschaft Prof. Hoberg & Partner

## **Abstract**

Processing of **Municipal Solid Waste (MSW)** before **Anaerobic Digestion (AD)** is highly considerable in terms of capital expenditure (CAPEX) and operational expenditure (OPEX). The paper determines different process options like “Standard” and “AdvancedBioSolids” and characterizes the process options. The “Standard” option is relatively simple and comprises only few process steps. The “AdvancedBioSolids” option is more complex and refines the biosolid fraction by segregating inorganic items and other non-digestibles in a multi-stage dry refining process.

Model calculation of mass balance and product quality is based on a typical composition of MSW in western urban settlements, this is e.g. 41 mass-% of digestible biomass. The quality of digestible biomass going from pre-processing to digestion is increased from 71,2 %, achieved by a “Standard” process to, 93,9 %, achieved by an “AdvancedBio-Solid” process.

The calculation of CAPEX is done for annual capacities of 180.000 t/y and of 310.000 t/y. As a result CAPEX for mechanical equipment for pre-processing is 15 to 30% of CAPEX for total mechanical equipment, this means pre-processing plus digestion, combined-heat and power (CHP) and emission reduction installation. Calculation of OPEX is done by summarizing all operational costs deriving from the pre-processing plus digestion, CHP and emission reduction. As a result higher CAPEX for pre-processing installation leads to lower OPEX. OPEX as a function of CAPEX for pre-processing can be seen as a graph of different gradient.

The paper finalizes with a draft of a catalogue of pre-processing steps and their relevance for product quality and yield. Decision makers of authorities and companies get a hint of what is relevant in terms of process evaluation and meeting the targeted figures of OPEX.

## **1 Processing of Municipal Solid Waste before Anaerobic Digestion**

### **1.1 Flow sheets**

Processing of Municipal Solid Waste (MSW) before Anaerobic Digestion (AD) is commonly done in processes comprising a screen cut and metal separation. The screen cut applies cut- sizes of about 40 to 60 mm, and metal separation applies magnetic and eddy-current separation. The process flowsheet of a so- called “Standard” – process can be summarized as follows:

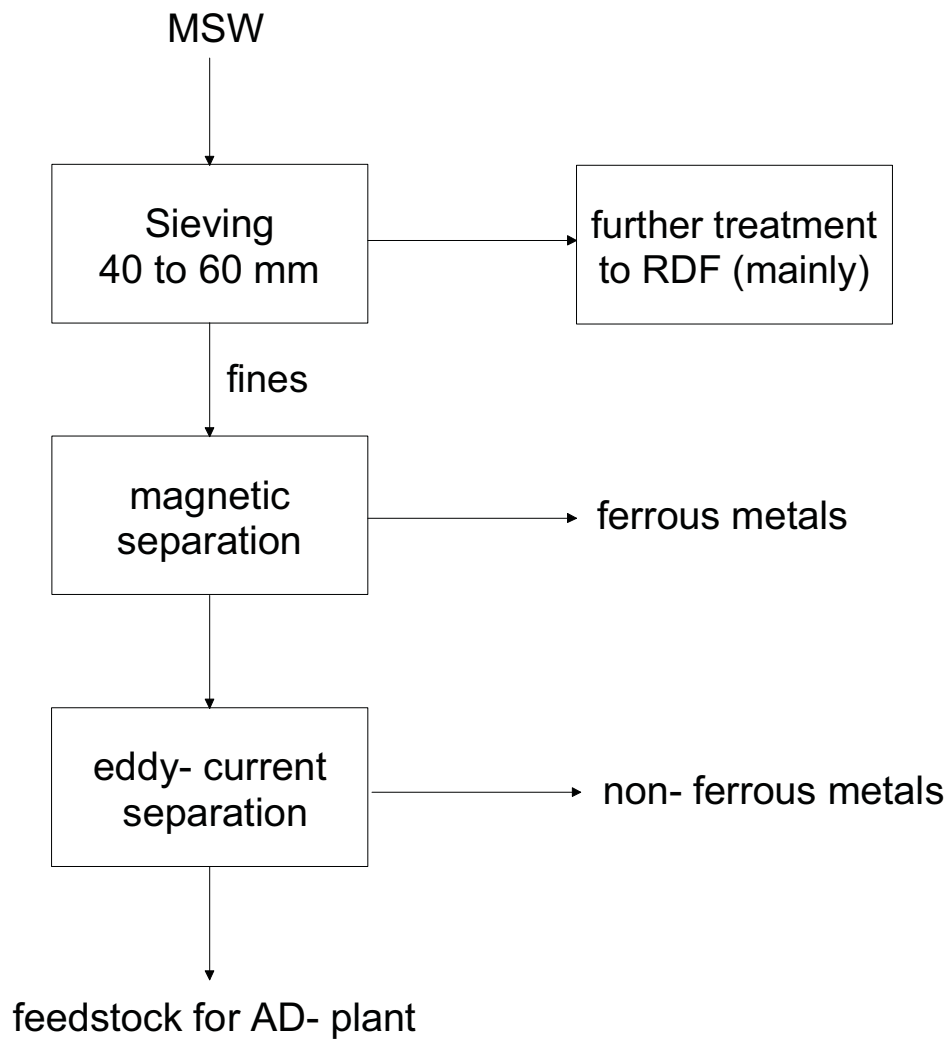

Figure 1 Flow sheet MSW

The composition of the feed for the AD- plant is roughly 2/3 digestible organic items and 1/3 other items, mainly inert items like glass, stone, ceramic etc. and non- digestible organics like plastic, fibres etc. The quality of the feed for the AD- plant can be enhanced in terms of the grade of digestible biomass by using a more sophisticated dry mechanical pre- processing. The process flowsheet of a so- called “AdvancedBioSolids” – process can be summarized as follows:

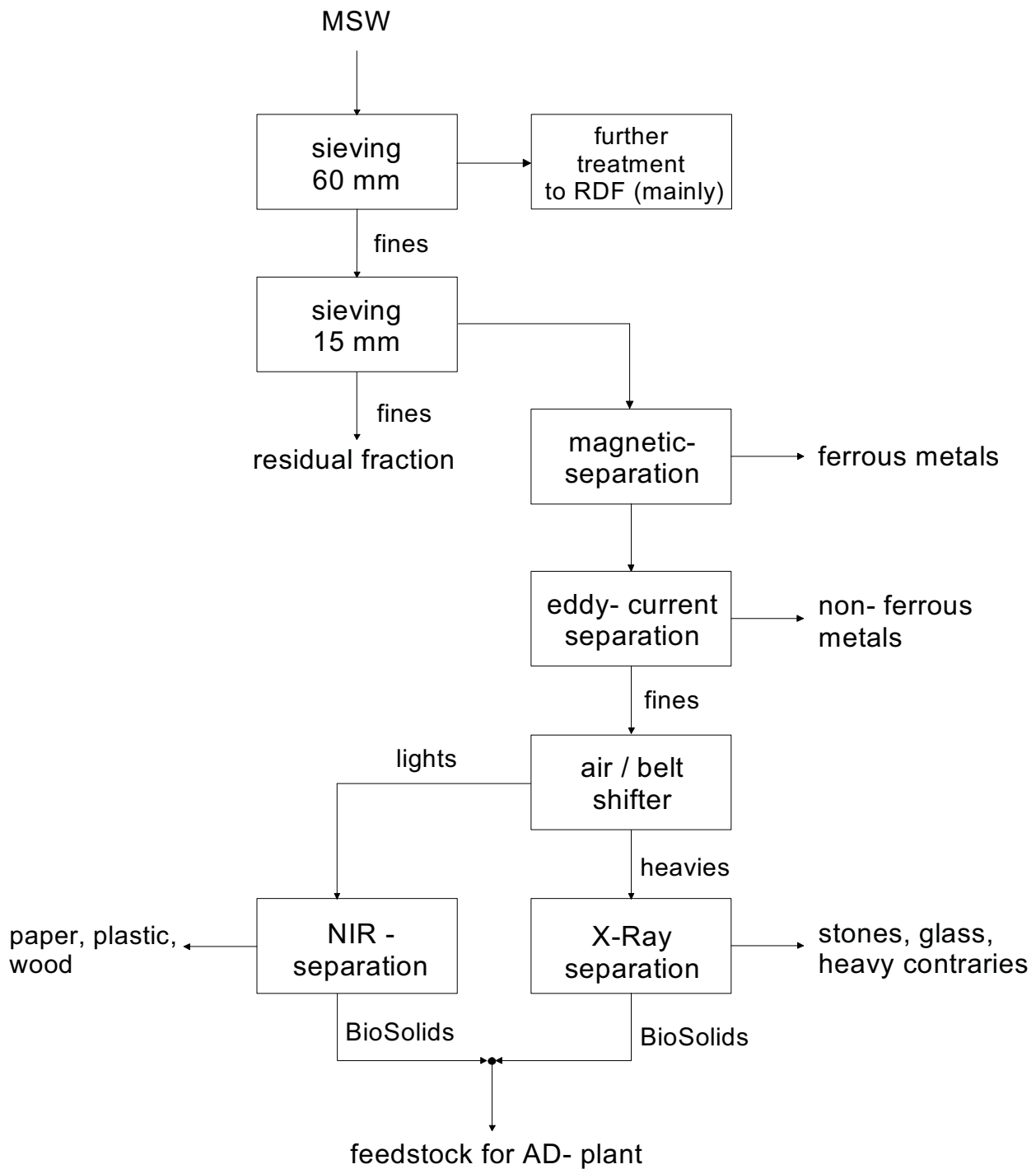

Figure 2 Flow sheet „AdvancedBioSolids“

## 1.2 Mass- balance and Qualities

The composition of the feed for the AD- plant is given in table 1 as a comparison between the “Standard”- process and the “AdvancedBioSolid”- process based on a process model. The process model is based on an average composition for MSW (1) and sorting efficiencies of process equipment documented in the HTP database.

Table 1 Composition of MSW input (curbside) and feed for the AD- plant depending on the type of pre- processing (dry- mechanical).

	Input MSW-	feed to AD- plant	
	curbside collection (1)	Standard process (2)	Advanced Bio Solid process (2)
kitchen and garden waste (Bio Solids)	41%	71,20%	93,90%
paper / cardboard	18%	4,20%	1,10%
metal cans	3%	0,00%	0,00%
plastic	7%	2,00%	0,60%
glass	7%	4,70%	1,10%
wood	5%	0,50%	0,50%
sand, stones, ceramic	5%	6,80%	0,50%
textiles	3%	0,00%	0,00%
whitegoods, nappies, miscellaenous, non combustables	11%	10,60%	2,30%
	100%	100%	100%

(1) Analysis of household waste compositions for England, Dr. J. Parfitt, WRAP 2002

(2) HTP - database

The first column from the left gives an exemplary composition of MSW derived from curbside collection. In this case an average composition of household waste in England was chosen. The second and third column from the left shows the composition of the feed for the AD- plant produced by pre- processing in a “Standard” and an “Advanced-BioSolid” process. Whereas the commonly applied “Standard”- process shows a grade of only 71,2 % digestible biomass the “AdvanceBioSolid”-process increases the grade up to 93.9 %. The “Standard”- process feeds the wet- mechanical AD- plant with a ma- EU Waste Management 2010

terial containing 11,5 % heavies (glass, stone, sand, ceramic), 4,2 % paper fibres and 2,0 % plastics. Those items cause significant operational problems and costs. The “AdvancedBioSolids”- process decreases those items significantly to 1,6 % heavies, 1,1 % paper fibres and 0,6 % plastics.

The loss of digestible biomass by the “AdvancedBioSolids”- process is less significant. The “Standard”- process feeds 88,9 % of the total digestible biomass of MSW to the AD- facility whereas the “AdvancedBioSolid”- process feeds 82,1 % of the total digestible biomass to the AD- plant. The biogas- production is not affected significantly. The mass- output of pre- processing to AD is reduced from 51,4 % to 35,4 % which leads to higher overall plant- capacities and lower CAPEX and OPEX.

## **2 CAPEX and OPEX as model calculation**

CAPEX and OPEX for a MSW- AD- plant is calculated on the basis of four scenarios.

Scenario 1: 180.000 t per year capacity

Standard- process

Scenario 2: 180.000 t/y capacity

AdvBioSol- process

Scenario 3: 310.000 t/y capacity

Standard- process

Scenario 4: 310.000 t/y capacity

AdvBioSol-process

### **2.1 Capital Expenditure (CAPEX)**

CAPEX is calculated for mechanical and electrical works only. CAPEX of civil works, such as infrastructure, halls and office space is not calculated as it is not affected by the choice of a process option. Figures may vary depending on a specific site or project more or less. In general the figures give an estimate for a project developed from scratch, based on AD- plants built and operated in Germany mainly.

Table 2 CAPEX of scenario 1 and 2, annual capacity 180.000 t MSW.

	<b>process option Standard</b>	<b>ADVBioSol</b>
<b>pre-processing</b>	5.500.000,00 €	7.000.000,00 €
<b>AD-plant</b>	17.500.000,00 €	16.500.000,00 €
<b>emission-control</b>	2.800.000,00 €	2.800.000,00 €
<b>process control</b>	1.100.000,00 €	1.100.000,00 €
<b>total</b>	26.900.000,00 €	27.400.000,00 €

CAPEX for pre- processing rises by 1.5 Mio. or 27 % from 5.5 Mio. € to 7.0 Mio. € whereas the overall CAPEX rises by just 0.5 Mio. € from 26.9 Mio. € to 27.4 Mi. €

Table 3 CAPEX of scenario 3 and 4, annual capacity 310.000 t MSW.

	<b>process option Standard</b>	<b>AdvBioSol</b>
<b>pre-processing</b>	8.250.000,00 €	11.250.000,00 €
<b>AD-plant</b>	26.200.000,00 €	21.500.000,00 €
<b>emission-control</b>	4.200.000,00 €	4.200.000,00 €
<b>process control</b>	1.600.000,00 €	1.600.000,00 €
<b>total</b>	40.250.000,00 €	38.550.000,00 €

CAPEX for pre- processing rises by 3.0 Mio. € or 36 % from 8.25 Mio. € to 11.25 Mio. € whereas the overall CAPEX drops by 1.8 Mio. € from 40.25 Mio. € to 38.55 Mio. €

Savings of CAPEY for the AD plant is possible because of a significant lower mass throughput, 35,4 % instead of 51,4 %, without much loss of biomass and biogas production for mainly the contraries are separated.

Calculation of OPEX is done on the basis of the following assumptions:

- The lifetime of the plant is 15 years. The interest rate of capital is 4.5 %.
- The runtime of the plant is 7 days a week, 24 h daily in a four shift pattern. This applies for the AD-, emission control and CombinedHeatPower (CHP) - plant. The reception hall and pre- processing is being operated on weekdays only.
- Biogas is being used in a CHP unit. Electricity of CHP is consummated by the plant itself, the surplus of electricity into the grid are calculated with 0,065 €/ kWh.
- Heat from CHP is being used to warm up the digesters. The surplus of heat is not distributed or marketed any further.
- The number of operating personal is 16 people per shift for the 180.000 t/y scenarios respectively 22 people per shift for the 310.000 t/y scenarios. A plant manager and four people are calculated for each scenario additionally.
- Operational costs of civil works, infrastructure and material transport (internally) are not calculated in accordance to CAPEX calculation where those costs are left blank as well.
- Costs or returns for process products such as metals, rdf, adgeslota are nit calculated.

Figures of OPEX ranges from 27,00 €/t, 310.000 t/y AdvBioSol- process, to 35,00 €/t, 180.000 t/y Standard- process. Table 4 gives an overview.

*Table 4 OPEX of an MSW- AD- plant dependent on capacity and process option.*

	180.000 t/y		310.000 t/y	
	Standard	AdvBioSol	Standard	AdvBioSol
<b>OPEX (absolute)</b>	35,0 €/t	33,1 €/t	29,7 €/t	27,1 €/t
<b>OPEX (relative)</b>	100%	-5%	100%	-9%

Savings of OPEX are mainly due to the economy of scale, a loss of about 5,00 €/t by increasing the capacity from 180.000 t/y to 310.000 t/y. Beside savings due to choosing a more sophisticated dry- mechanical processing are -5 % respectively -9 %.



### 3 Summary and main findings

Investors, plant- operators and construction firms should look at dry mechanical processing before Anaerobic Digestion (AD) with more emphasis. More sophisticated dry-mechanical processing leads to

- higher grades of BioSolids and lower grades of non- digestible items in the feed of the AD- plant.
- lower operational expenditures- OPEX, sometimes even lower capital expenditures- CAPEX and
- higher process reliability, particularly in the AD- part of the plant, by preventing contraries from being fed to the digesters.

#### **Author's address:**

Dr.-Ing. Michael Langen  
HTP Ingenieurgesellschaft Prof. Hoberg & Partner  
Maria-Theresia Allee 35  
52064 Aachen  
phone +49 241 94900 0  
email: [langen@htp.eu](mailto:langen@htp.eu)

# **Endeavours of Poland to reach a high standard of municipal waste management**

**Magdalena Rybaczewska-Błażejowska**

Państwowa Wyższa Szkoła Zawodowa w Ciechanowie, Poland

## **Abstract**

While much is known about the requirements of the European Union on municipal waste management in general, comparatively little knowledge is about the implementation of these requisites in the individual member states. Each of these countries experiences some problems with municipal solid waste and thus needs to work out its own approach to these problems. Consequently, the intention of this paper is to inform the reader about the undergoing changes in the municipal waste sector in Poland. As, corresponding to the National Waste Management Strategy for Poland 2010, the system for municipal waste management will rely on regional organisations, established by one or several cooperating communes, this paper examines the case of the Association of Communes from the Ciechanow Region. The practice shows, though, that only such organisations are able to provide highly integrated solutions for materials and energy recovery from the stream of municipal solid waste and finally, if necessary, environmentally sound deposition.

## **Keywords**

Municipal solid waste, integrated waste management, Polish waste sector, the Association of Communes from the Ciechanow Region

## **1 Municipal waste management in Poland - the state of the art**

From the beginning of the preparation for accession to the European Union, Poland has certainly made great progress in strengthening the system of waste management. Over the last 20 years, the municipal waste problems, though not yet solved, have begun to be recognised and addressed. The National Waste Management Strategies for Poland, published in 2002 and 2006, have undoubtedly played a stimulating role for the improvement of functioning of the municipal solid waste sector. These documents have defined, though, the priorities and objectives as regards the waste management in Poland. Therefore, it will be required in the near future, among others,:

- to cover 100 percent of population by the selective collection of municipal solid waste,
- to reduce the landfilling of biodegradable waste to levels required by the Council Directive 1999/31/EC,

- to reduce the level of municipal solid waste landfilling to maximum 85% by 2014.

Despite the dynamic progress in the management of municipal waste in Poland, the time-limits for fulfilling these and other objectives of the National Waste Management Strategy 2010 may require some alteration.

### 1.1 Generation, collection and composition of municipal solid waste

According to the Polish Central Statistical Office, 124974 thousand tonnes of waste was generated in Poland in 2008. Of this, 12195 thousand tonnes (approximately 10 percent) was municipal waste. Covering the level of municipal waste generation into kg per capita per year, an estimated **320 kg of municipal waste was produced per person in Poland** in 2008.

Out of 12195 thousand tonnes of municipal waste generated in Poland in 2008, 10036 thousand tonnes was collected since not the whole population of Poland is still covered by the collection system. This makes 263 kg per person. There are apparent differences in the generation (collection) levels of municipal solid waste between urban and rural areas in Poland. In 2008, population of cities was responsible for 81 percent of the total amount of municipal waste collected.

In Poland in 2008, **682 thousand tonnes of municipal solid waste was collected selectively. This represents 6.8 percent** – not much considering the objectives of the National Waste Management Strategy for Poland 2010, a lot in the comparison with the beginning of 2000, where there was no selective collection of municipal solid waste in Poland or a split percent of waste (mostly paper, glass and aluminium) was selectively collected. Currently, as depicted at the figure 1, paper and cardboard, glass, plastics, biodegradable and bulky waste are the main streams of municipal solid waste selectively collected at source. Besides, people in many regions has been given the opportunity to select textiles, metals and hazardous waste, for instance batteries and medicines.

The applied system for the collection and transportation of municipal solid waste in Poland does not differ from the European standards. Depending on the types of residential dwellings either a combination of on-site collection of commingle waste and off-site collection of dry recyclables in 2.5 m<sup>3</sup> capacity containers is applied or on-site collection of commingle and dry recyclables in bags is used. In both cases, dry recyclables have to be divided into individual streams of materials – the most often glass, paper and plastics together with metals.

## 1.2 The system of municipal solid waste transformation and disposal

The Waste Act of 27<sup>th</sup> April 2001 has introduced the waste hierarchy; a universally adopted system in the EU of preferred waste management approaches. The fundamental aim of introducing the waste hierarchy in Poland was to encourage waste transformation prior waste disposal.

Materials and energy recovery from municipal solid waste through physical, biological and chemical transformation encompasses a tiny percentage of municipal solid waste management in Poland. Following data of the Polish Central Statistical Office, for 10036 thousand tonnes of municipal solid waste collected in 2008, **1343 thousand tonnes was recovered, giving a level of 13.4 percent.**

To recover dry recyclable materials for the subsequent reprocessing processes in Poland either selective waste collection at source is applied or waste are collected as a mixture of materials that are separated in a sorting plant. In 2008, **336 thousand tonnes of dry recyclable was recovered** by manual or semi-automatic sorting processes. Besides the quality of materials recovered from municipal solid waste, the crucial problem of the recycling in Poland has been the variability of markets (offered prices and quality requirements) for the recyclable materials.

Regarding the biological conversion techniques applied in the management of municipal solid waste in Poland, they have still been in little use, which is in contrary to the legal requirements enforced. In 2008, **262 thousand tonnes of biodegradable municipal solid waste was recovered through composting processes in Poland that represents 2.6 percent.** The obtained compost is, first and foremost, applied to land reclamation and, provided adequate quality, to fertilisation in agriculture.

The chemical transformation (incineration) of municipal solid waste is hardly instituted in Poland since there is only one incineration plant, placed in Warsaw, in the whole country. In 2008, this plant processed **63 thousand tonnes of municipal solid waste.** Despite these poor results, a substantial expansion of the incineration of municipal solid waste (up to ten new plants) is expected by 2013. Strong public opposition (the NIMBY symptom), however, considerably restrains the initiation of this waste transformation method.

Disposal at landfill sites is still the primary method of municipal solid waste management in Poland. In 2008, **86.6 percent of municipal solid waste, 8693 thousand tonnes was placed at landfill sites** located around Poland. Converting the level of average municipal solid waste landfilling into kg per capita per year, an estimated **228 kg of municipal solid waste was disposed per person in Poland in 2008.** This is slightly

above the European average, which at that time was equal to 219 kg per capita. There are around 880 controlled sanitary landfill sites in operation in Poland that occupy 3000 ha of area. They are expected to operate to minimise public health and environmental impacts and hence all are sealed with geomembrane, equipped with a leachate collection system and 340 of them have a gas control system.

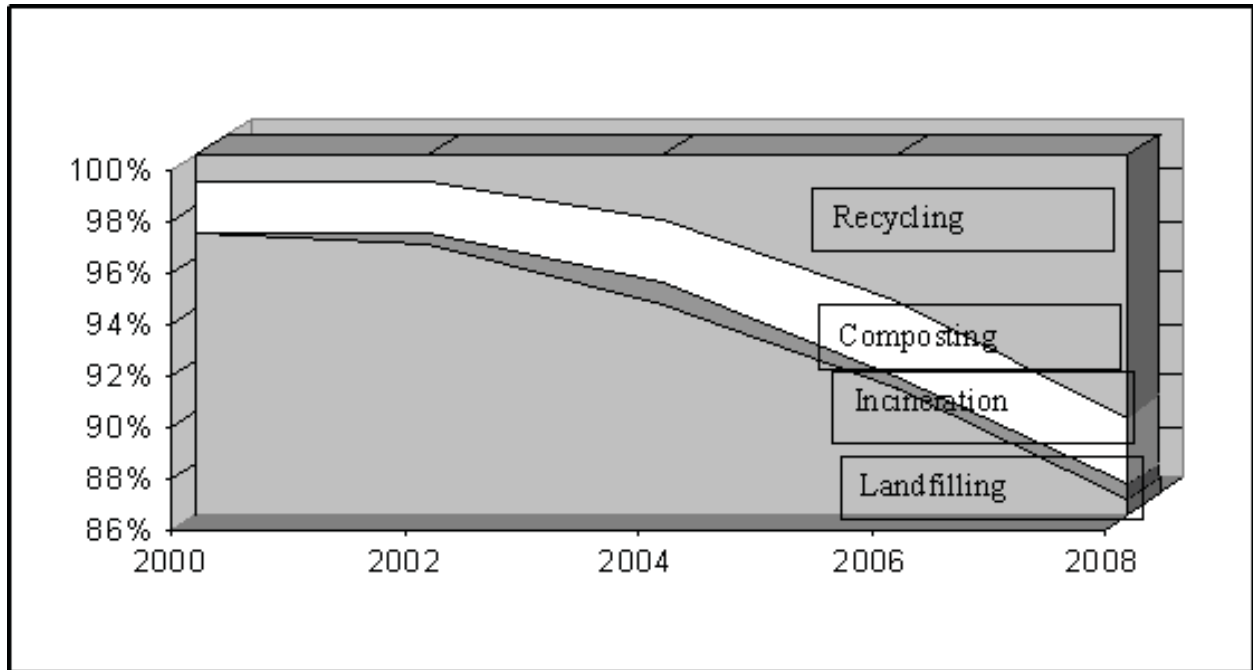

Figure 1 Management of municipal solid waste in Poland from 2000 to 2008

## 2 Organisational structure of the municipal waste sector – the case of the Association of Communes from the Ciechanow Region

In accordance with the Polish waste legislation, the management of municipal waste falls within the jurisdiction of communes. They have the right, however, to decide whether to manage their waste autonomously or together with neighbouring communes. Two or more local governments can establish 'an intercommunal structure' – a kind of regional organisation for an execution of their responsibilities with regard to the provision of waste collection, recovery and disposal services. It is also possible to restrict the co-operation between communes to one element only, for instance the disposal of municipal waste at a regional sanitary landfill site.

If only local governments are able to reach an agreement as to constituting the regional organisation they can largely benefit from this. First and foremost, such organisations have bigger money at their disposal and thus have a higher ability to adopt integrated, innovative solutions for municipal waste management being a response to the concept

of Best Available Techniques (BAT). In addition, thanks to better organisation, they have a wider access to external (also EU) funding. As a result, the regional organisations are in favourable situation regarding the fulfillment of current municipal waste regulation. The National Waste Management Strategy 2010 anticipates that **the management of municipal waste in Poland will soon rely on regional municipal waste treatment facilities that will serve at least 150 thousand dwellers.**

## 2.1 The Association of Communes from the Ciechanow Region

Understanding the need for changes to achieve more sustainable municipal waste management in Poland, the growing number of communes sign or are going to sign inter-communal agreements for joint waste management. This was the case of the Association of Communes “Dolina Redy i Chylonki” (located in the north part of Poland), the Intentional Association of Communes CZG-12 and the Association of Communes “Clean City, Clean Commune” (both located in the west part of Poland) and many other placed around Poland. It is essential for all, to provide such services that will substantially decrease the number of municipal solid waste going to landfill sites.

As in other Polish territories, municipal waste management in the Ciechanow Region (located in the central part of Poland) has been recently reorganised. Small, very often ineffective local municipal waste treatment facilities has established **the Association of Communes from the Ciechanow Region that unites 27 communes** from the following administrative districts – ciechanowski, przasnyski, makowski and pultuski. **It covers the area of 3500 km<sup>2</sup> and is inhabited by 210 thousand citizens.**

The central municipal waste treatment facility in Wola Pawlowska belonging to the Association of Communes from the Ciechanow Region will be responsible for the management of 60 thousand tonnes of municipal waste yearly, including their collection, the processing and finally sound deposition. To meet these objectives, the regional facility offers or is just about to offer integrated solutions allowing, among others,:

- the semi-automatic sorting processes together with the production of refused derived fuel, having the capacity of 50 thousand tonnes of municipal solid waste annually (at two shifts), which are collected selectively or as commingled waste,
- aerobic processing of 20 thousand tonnes of the organic fraction of municipal waste yearly in the BIODEGMA in-vessel system to produce good quality compost,

- deposition of municipal solid waste residues at the sanitary landfill site equipped with a leachate collection system and a landfill gas control system converting landfill gas into electric energy.

The total value of the project has been estimated at 88 million zloty (approximately 22 million euros).

### **3 EU waste requirements and Poland's possibilities to reach them**

These days all in Poland, irrespectively if they represent the municipal waste sector, the government or municipalities, have agreed that the traditional approach to municipal waste management that relied on local facilities landfilling most of their waste has no longer a *raison d'être* in Poland. It is not though clear yet, what will replace it. Corresponding to the National Waste Management Strategy 2010, it might be expected that the Polish system for municipal waste management will rely on regional organisations providing integrated solutions for materials and energy recovery from the stream of waste, and finally environmentally sound deposition. Much more difficult task, however, is to transfer the spirit of this sustainable language to the actions in the field among the practitioners. Although the near future will show, how Polish municipal waste treatment facilities cope with their environmental and socio-economic obligations, current practices appear to believe that they are on the good way to fulfil the European Union requirements.

### **4 Basic literature**

- |                               |      |  |
|-------------------------------|------|--|
| Główny Urząd Statystyczny     | 2009 | Environmental Protection 2008 – statistical yearbook, Zakład Wydawnictw Statystycznych   |
| Kundegórski, M                | 2008 | Environmental Impact Statement for the municipal waste treatment facility of the Association of Communes from the Ciechanow Region |
| Uchwała nr 233 Rady Ministrów | 2006 | National Waste Management Strategy 2010  |



**Author's address**

PhD Magdalena Rybaczewska-Blazejowska

Panstwowa Wyzsza Szkola Zawodowa w Ciechanowie (The University in Ciechanow)

Narutowicza Street 9

06-400 Ciechanow, Poland

Email: [magdalenarybaczewska@pwszciechanow.edu.pl](mailto:magdalenarybaczewska@pwszciechanow.edu.pl)



